

Circulating Fluid Temperature Controller

Thermo-chiller Compact Dual/Basic Type for Lasers

HRLE Series

Air-cooled Refrigeration

Water-cooled Refrigeration



Scheduled to acquire UL Standards (Only 400 V)

RoHS

With functions narrowed down, 2 independent temperature control systems have been achieved with only a single compressor, a single pump, and a single tank.

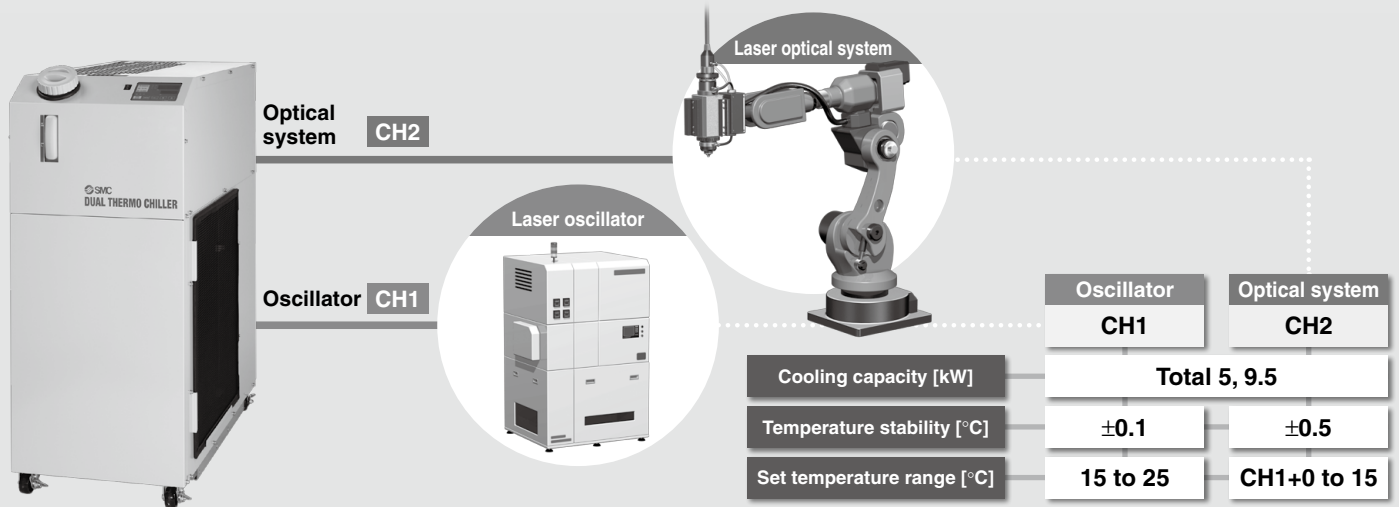

Space saving Footprint reduced by 21%

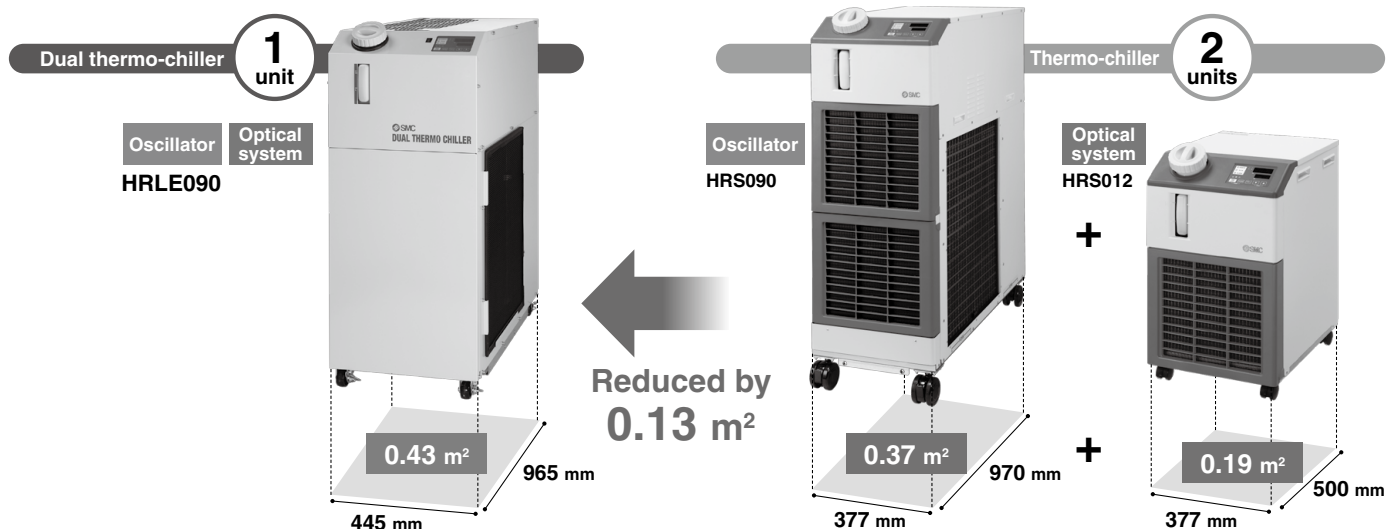

Energy saving Power consumption reduced by 17%

Globally compatible power supplies	50 Hz	60 Hz	50/60 Hz
3-phase 200 VAC	●		
3-phase 200 to 230 VAC		●	
3-phase 380 to 415 VAC		●	●
3-phase 460 to 480 VAC		●	
Single-phase 200 to 230 VAC			★

●: HRLE090 ★: HRLE050

Space saving

The temperatures of 2 fluid channel systems can be controlled individually.
Compact

Series	Height	Width	Depth
HRLE090	1055	445	965
HRS090	1080	377	970

[mm]

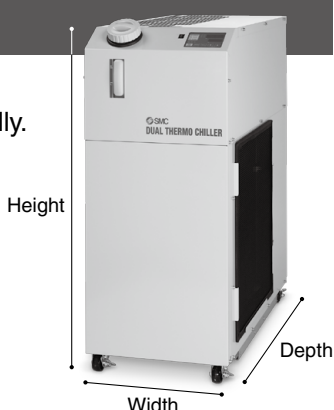

Reduced wiring/labor

One power supply system for temperature control of 2 channels
Less work-hour for wiring

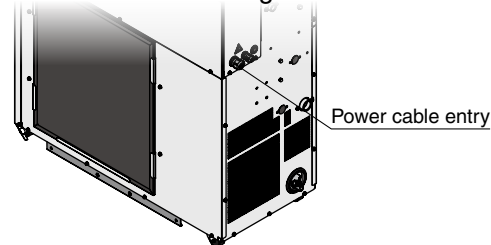

Energy saving

Power consumption reduced by 17%

- 1 compressor, fan, and pump
- Uses a heating method that does not require a heater

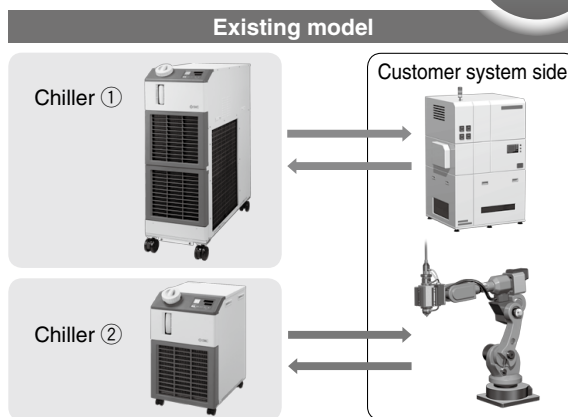
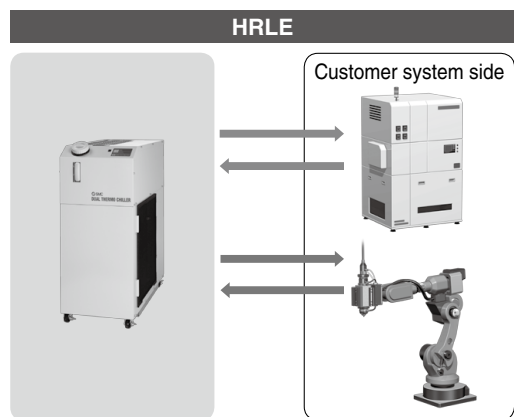
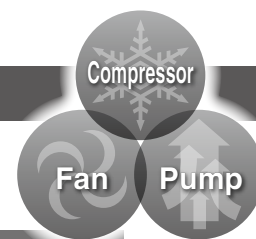

- Conditions**
- Outdoor air temperature: 32°C
 - Circulating fluid set temperature: 20°C/25°C (CH1/CH2)
 - Heat load in the customer equipment: 9.5 kW (CH1, 2 total)
 - Power supply: 200 V 60 Hz
 - Circulating fluid flow rate: 35 LPM/2 LPM (CH1/CH2) to the customer equipment
 - External piping: The shortest distance assumed to the customer equipment

Circulating fluid can be heated without a heater.

(Circulates the hot discharged gas through expansion valve B)

Hot discharge gas is recycled for heating.
Energy saving by heaterless heating function

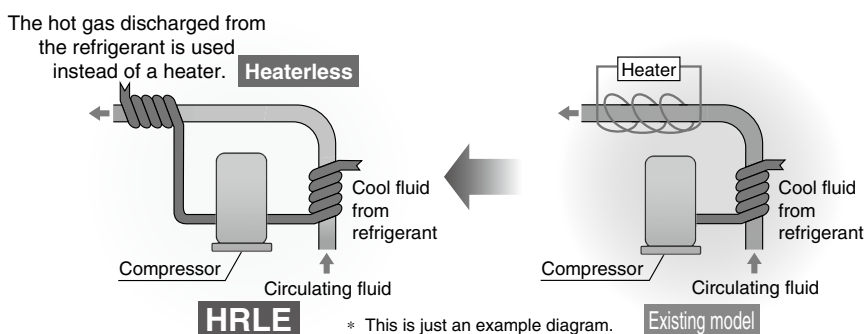

Variations

	Cooling capacity [kw]*1	Temperature stability [°C]		Set temperature range [°C]		Options p. 371	Accessories (Sold separately)
		CH1	CH2	CH1	CH2		
Air-cooled refrigeration pp. 355, 359	8.0/9.5	±0.1	±0.5	15 to 25	CH1 temperature + 0 to 15	• Increased cooling capacity function (With inverter for compressor) • Circulating fluid pressure adjustment function (With inverter for pump) • Deionized water (Pure water) piping	• G/NPT thread conversion fitting set • Bypass piping • Electric conductivity control (DI filter + Solenoid valve for control) • Particle filter • Automatic fluid fill set • Ball valve set (With pressure gauge)
Water-cooled refrigeration pp. 357, 360	9.5/11.0						

*1 CH1, 2 total, 50/60 Hz

One compressor controls 2 channels.

Temperature of **CH1: Oscillator** and **CH2: Optical system** is controlled individually.

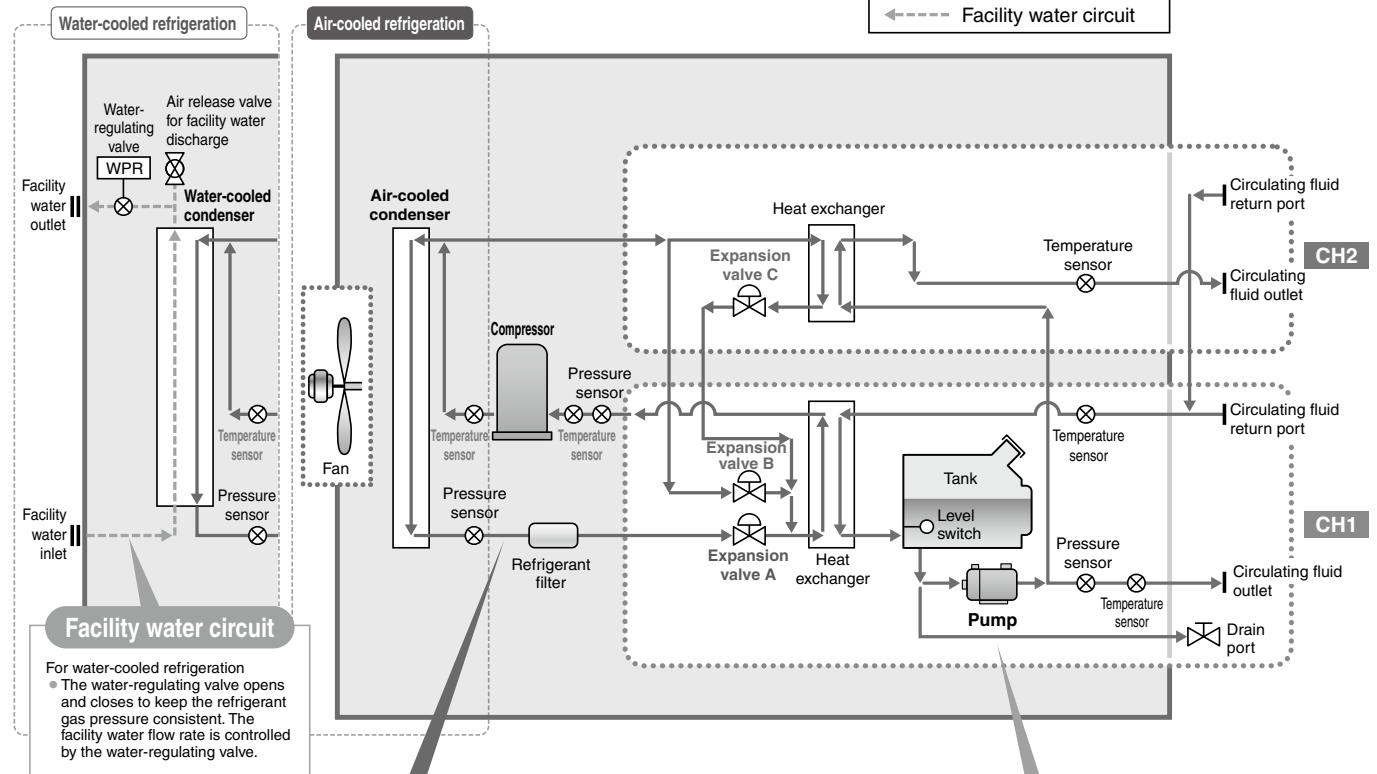

Facility water circuit
For water-cooled refrigeration
• The water-regulating valve opens and closes to keep the refrigerant gas pressure consistent. The facility water flow rate is controlled by the water-regulating valve.

Refrigeration circuit

- The compressor compresses the refrigerant gas and discharges high-temperature, high-pressure refrigerant gas.
- In the case of air-cooled refrigeration, the high-temperature, high-pressure refrigerant gas is cooled down by fan ventilation in the air-cooled condenser, where it is then liquefied.
- The liquefied high-pressure refrigerant gas expands and its temperature lowers when it passes through expansion valve A, where it vaporizes after receiving heat from the circulating fluid in the evaporator.
- The vaporized refrigerant gas is sucked into the compressor and compressed again.
- When heating the circulating fluid, the high-pressure, high-temperature refrigerant gas is bypassed into the evaporator by expansion valves B and C to heat the circulating fluid.
- In the case of water-cooled refrigeration, the refrigerant gas is cooled by the facility water in the facility water circuit in the water-cooled condenser, where it is then liquefied.

POINT The combination of the precise control of expansion valves A, B, and C realizes energy saving operation without waste and high temperature stability.

POINT One compressor controls 2 channels which realize the independent temperature control of 2 systems.

Circulating fluid circuit

- After the circulating fluid discharged from the pump is heated or cooled by the customer system side, it returns to the tank.
- The circulating fluid is sent to the heat exchanger by the pump, and is controlled to a set temperature by the refrigeration circuit, to be discharged to the customer system side again by the thermo-chiller.

POINT Adjusting the discharge pressure by pump inverter control eliminates wasteful discharge of the circulating fluid and realizes energy saving operation.

POINT Since the refrigeration circuit is controlled by the signals from 2 temperature sensors (for return and discharge), precise temperature control of the circulating fluid can be achieved. Therefore, there is no need for a tank with a large capacity to absorb the circulating fluid temperature difference, as high temperature stability can be achieved even with a small-size tank. This also contributes to space saving.

* When the inverter option is equipped

Temperature stability: $\pm 0.1^\circ\text{C}$ (CH1) When a load is stable

By controlling the inverter fan and electronic expansion valve simultaneously, it maintains the good temperature stability when the heat load fluctuates.

* For HRLE090-A-20

- Conditions**
- Outdoor air temperature: 32°C
 - Circulating fluid set temperature: 20°C/25°C (CH1/CH2)
 - Heat load in the customer equipment: 9.5 kW (CH1, 2 total)
 - Power supply: 200 V 60 Hz
 - Circulating fluid flow rate: 35 LPM/2 LPM (CH1/CH2) 60 Hz
 - External piping: Bypass piping + Heat load

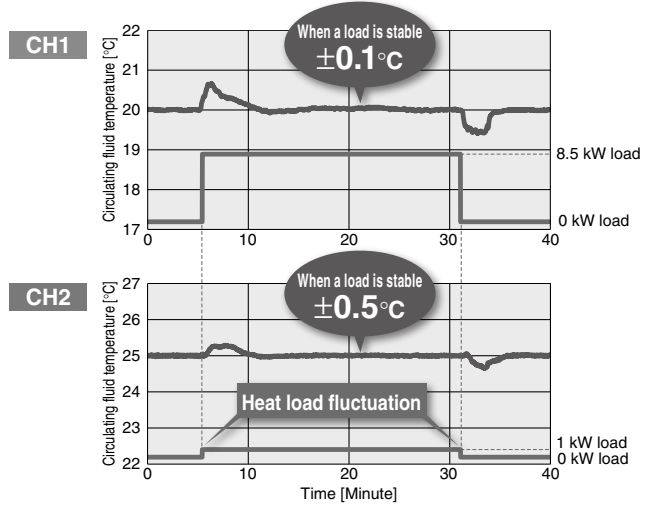

Electric conductivity control set (With DI filter + Solenoid valve kit for control) p. 374

The electric conductivity of the circulating fluid can be set with the controller monitor arbitrarily.

Set control range:
0.5 to 45.0 $\mu\text{S}/\text{cm}$

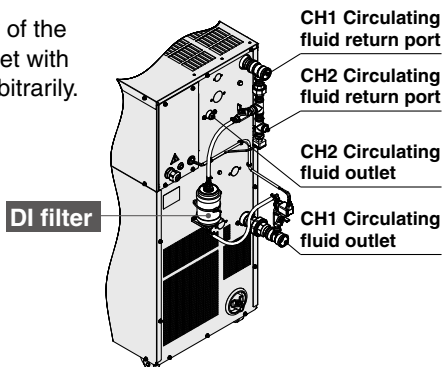

Particle filter set p. 375

Removes foreign matter in the circulating fluid

Effective in preventing foreign matter from entering the customer equipment and chiller

- Prevents pump malfunction
- Prevents the water-cooled condenser performance from falling

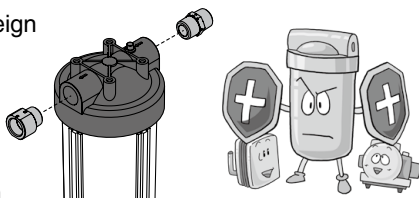

Simple operation

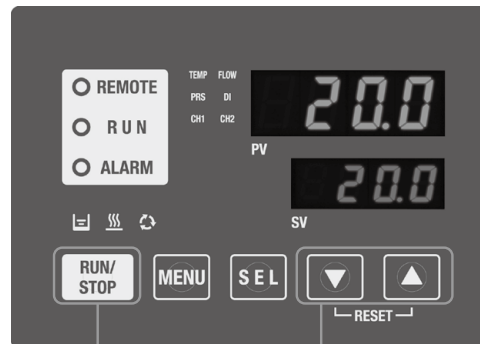

Step 1 Press the **RUN/STOP** key.

Step 2 Adjust the temperature setting with the **▼ / ▲** keys.

Step 3 Press the **RUN/STOP** key to stop operation.

Easy operation

Large digital display

The large digital display (7-segment and 4 digits) and 2-row display provide a clearer view of the current value (PV) and set value (SV).

Protection of the electrical unit: IPX4

The board and electric parts are located inside the electrical box, where they can be protected from dust particles and water splashing.

Electrical box **IPX4**

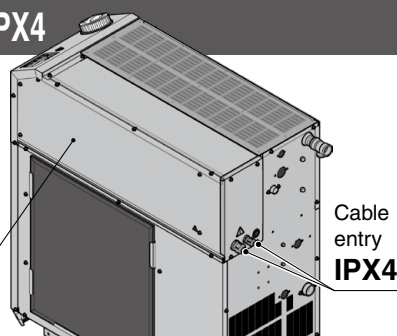

Easy to check the circulating fluid level

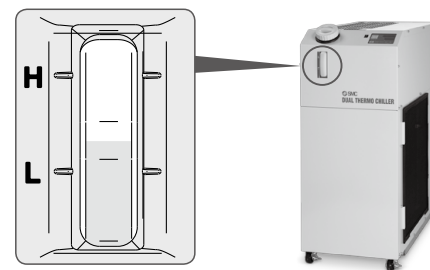

Circulating fluid can be heated without a heater.

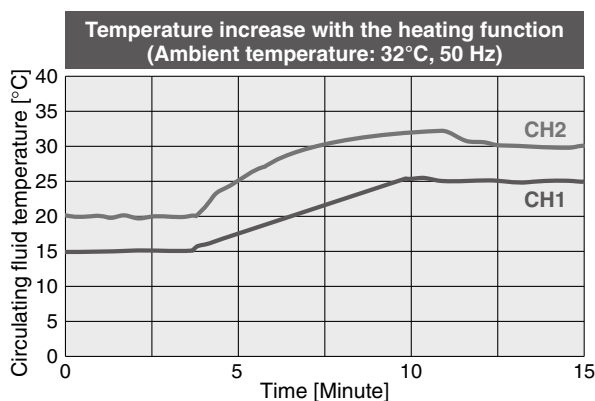

* For HRLE090-A-20

- Conditions**
- Ambient temperature: 32°C ● Power supply: 200 V 50 Hz
 - Circulating fluid flow rate: [CH1] 35 L/min at 0.5 MPa, [CH2] 2 L/min at 0.5 MPa
 - Circulating fluid temperature: [CH1] 15°C → 25°C, [CH2] CH1 + 5°C
 - External piping: Bypass piping

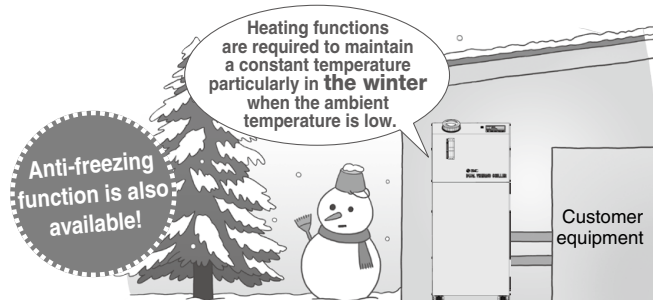
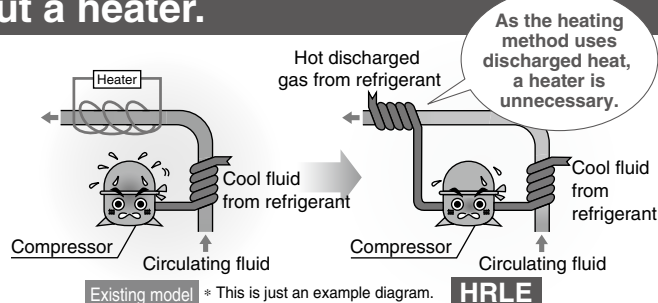

Globally compatible power supplies

(Europe, Asia, Oceania, Central and South America)

No transformers required

Power supply

**Applicable to 200 to 230 VAC,
380 to 415 VAC, or 460 to 480 VAC**

Transformers are not required even when used overseas.

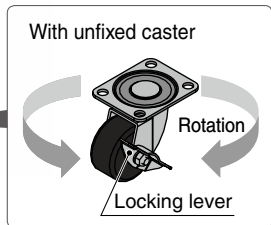
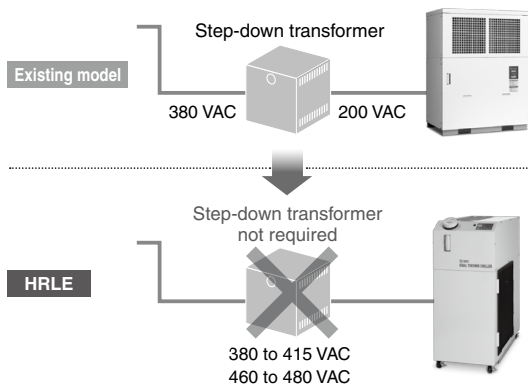

Shaped for easy supply of circulating fluid

The angled supply port facilitates the easy supply of circulating fluid.

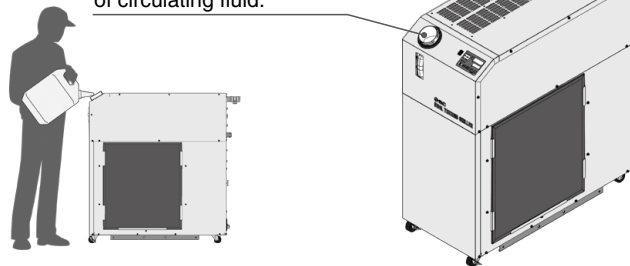

Easy cleaning of the tank

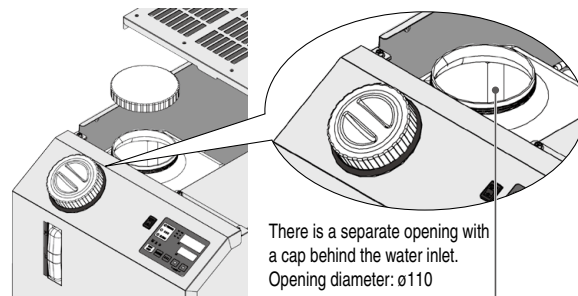

Toolless inspection and cleaning of air-cooled condenser

* For air-cooled refrigeration

Dustproof filter

* It can be removed with no tools.

Easy to remove dust, cutting chips, etc., stuck to the dustproof net with a brush or air blow

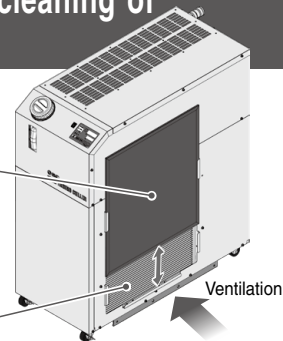

Power supply (24 VDC) available

Power can be supplied from the terminal block on the rear side to external switches, etc.

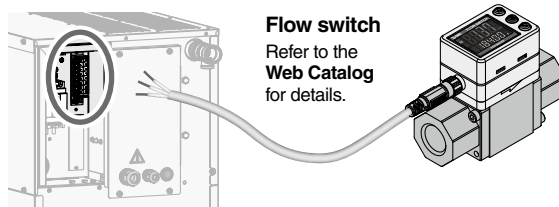

Increased cooling capacity function (Option) * HRLE090 only

The inverter for compressor increases the cooling capacity of the 50 Hz area to that of the 60 Hz area.

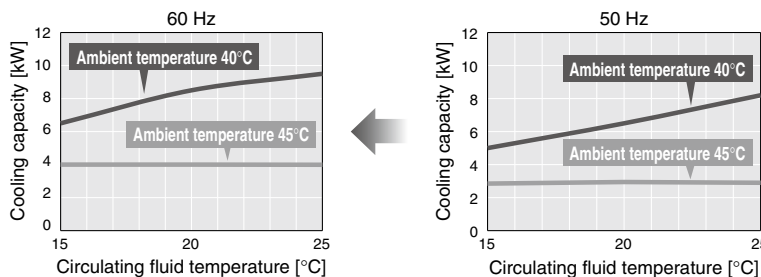

Convenient functions (Refer to the Operation Manual for details.)

■ Anti-freezing operation function

If the circulating fluid approaches its freezing point, for example, on a cold winter night, the pump operates automatically, and the heat generated by the pump warms the circulating fluid, preventing freezing.

■ Function to output a signal for completion of preparation

Notifies by communication when the temperature reaches the pre-set temperature range

■ Key-lock function

Can be set in advance to protect the set values from being changed by pressing keys by mistake

Self-diagnosis function and check display

Display of individual alarm codes

For details, refer to page 369.

Operation is monitored at all times by the integrated sensor. Should any error occur, the self-diagnosis result is displayed by the applicable alarm code. This makes it easier to identify the cause of the alarm. Can be used before requesting service

Changeable alarm set values

Setting item	Set range
Circulating fluid discharge pressure rise	0.3 to 0.6 MPa
Circulating fluid discharge pressure drop	0.05 to 0.6 MPa

Ex. AL01 "Low level in tank"

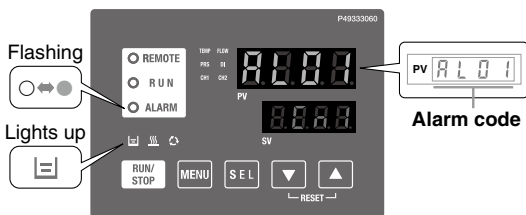

Check display

The internal temperature, pressure, and operating time of the product are displayed.

Ex. RUN "Accumulated operating time of the thermo-chiller"

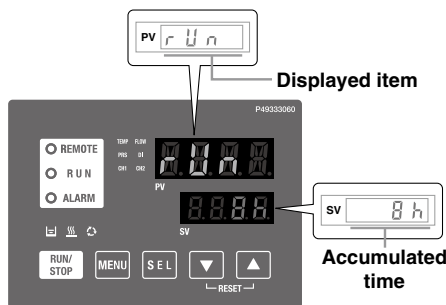

Displayed item
Circulating fluid outlet temperature
Circulating fluid return temperature
Compressor gas temperature
Circulating fluid outlet pressure
Compressor gas discharge pressure
Compressor gas return pressure
Accumulated operating time of the thermo-chiller
Accumulated operating time of the pump
Accumulated operating time of the fan*1
Accumulated operating time of the compressor
Accumulated operation time of the dustproof filter*1

*1 These are displayed only for air-cooled refrigeration.

Communication functions p. 370

Serial communication (RS485) and contact I/Os (2 inputs and 3 outputs) are equipped as standard.

This allows for communication with the customer equipment and system construction, depending on the application.

A 24 VDC output can be also provided and is available for use with flow switches (SMC's PF3W, etc.).

Communication cable

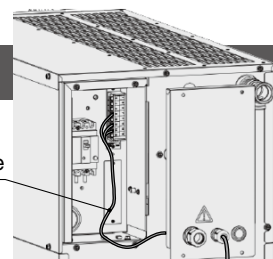

Ex.1 Remote signal I/O through serial communication

Remote operation is enabled (to start and stop operation) through serial communication.

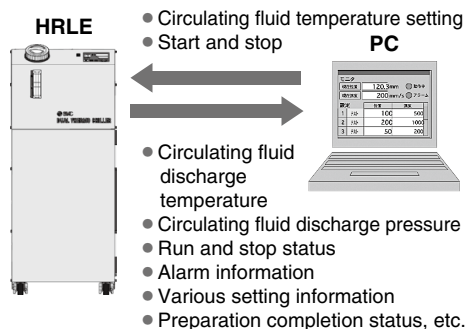

Ex.2 Remote operation signal input

One of the contact inputs is used for remote operation and the other is used to monitor the flow of a flow switch. This is where their alarm outputs are taken in.

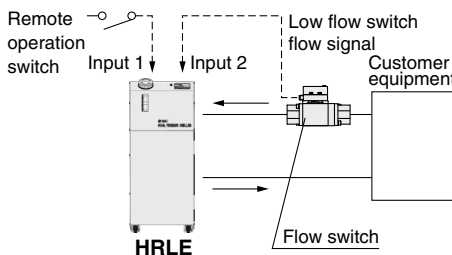

Power for flow switches (24 VDC) can be supplied by the thermo-chiller.

Ex.3 Alarm and operation status (start, stop, etc.) signal output

The alarm and status generated in the product can be output.

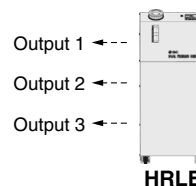

Output examples

- Output 1: Operation status (start, stop, etc.)
- Output 2: Alarm status signal
- Output 3: Preparation completion status signal

CONTENTS

HRLE Series **Compact Dual/Basic Type for Lasers**



Air-cooled refrigeration



Water-cooled refrigeration

Thermo-chiller HRLE Series

How to Order/Specifications

Air-cooled refrigeration (Single-phase 200 to 230 VAC)	.. p. 355
Air-cooled refrigeration (3-phase 200 to 230 VAC)	.. p. 356
Water-cooled refrigeration (Single-phase 200 to 230 VAC)	.. p. 357
Water-cooled refrigeration (3-phase 200 to 230 VAC)	.. p. 358
Air-cooled refrigeration (3-phase 400 VAC)	.. p. 359
Water-cooled refrigeration (3-phase 400 VAC)	.. p. 360
Cooling Capacity p. 361
Heating Capacity p. 362
Pump Capacity p. 363
Required Facility Water Flow Rate p. 363
Dimensions p. 364
Parts Description p. 364
Recommended External Piping Flow p. 368
Cable Specifications p. 368
Function of Each Part p. 368
Operation Display Panel p. 369
Alarm p. 369
Communication Functions p. 370

● Options

With Inverter for Compressor p. 371
Deionized Water (Pure Water) Piping p. 371
With Inverter for Pump p. 371

● Optional Accessories

① Piping Conversion Fitting p. 372
② Bypass Piping Set p. 373
③ Electric Conductivity Control Set p. 374
④ Particle Filter Set p. 375
⑤ Filter for Circulating Fluid Fill Port p. 376
⑥ Automatic Fluid Fill Set p. 376
⑦ Ball Valve Set (With Pressure Gauge) p. 376

● Cooling Capacity Calculation

Required Cooling Capacity Calculation p. 377
Precautions on Cooling Capacity Calculation p. 378
Circulating Fluid Typical Physical Property Values p. 378

Specific Product Precautions p. 379
------------------------------	--------------

Thermo-chiller Compact Dual/Basic Type for Lasers

Single-phase 200 to 230 VAC (50/60 Hz)

HRLE Series



How to Order

Air-cooled refrigeration

HRLE 050 - A - 20 -

Cooling capacity

	CH1, 2 total
050	5 kW

Cooling method

A	Air-cooled refrigeration
---	--------------------------

Power supply

20	Single-phase 200 to 230 VAC (50/60 Hz)
----	--

Option

Nil	None
M	Deionized water (Pure water) piping

• Options "C" and "P" are not available for the HRLE050.



Air-cooled refrigeration

Specifications

Model		HRLE050-A-20	
Cooling method		Air-cooled refrigeration	
Refrigerant		R410A (HFC)	
Refrigerant charge	kg	1.32	
Control method		PID control	
Ambient temperature		°C	
Circulating fluid*1		Tap water, Deionized (pure) water	
Set temperature range		°C	
Cooling capacity (CH1, 2 total) 50/60 Hz*2		kW	
Heating capacity (CH1, 2 total) 50/60 Hz*3		kW	
Temperature stability*4		°C	
Circulating fluid system	Pump capacity	Rated flow 50/60 Hz*5	L/min
		Max. flow rate 50/60 Hz	L/min
	Max. pump head 50/60 Hz		m
	Min. operating flow rate 50/60 Hz*6		L/min
Tank capacity (CH1, 2 total)		L	
Circulating fluid outlet, Circulating fluid return port		CH1: Rc1/2, CH2: Rc1/2	
Tank drain port		Rc1/4	
Fluid contact material		Stainless steel, Copper (Heat exchanger brazing), Bronze (Pump), Ceramic, Carbon, FKM, PP, PE, POM, PVC, PA, EPDM	
Fluid contact material (-M)		Stainless steel (Heat exchanger brazing), SiC, Carbon, FKM, PP, PE, POM, PVC, PA, EPDM, PTFE	
Electrical system		Power supply	
Earth leakage breaker (Standard)		Rated current	A
		Sensitivity current	mA
		Rated operating current 50/60 Hz	A
		Rated power consumption 50/60 Hz	kW(kVA)
Communication function		Contact input/output, Serial communication (RS-485)	
Noise level*7 50/60 Hz		dB(A)	
Accessories*8		Operation Manual (for installation/operation) 2 copies (English 1 pc./Japanese 1 pc.), Anchor bolt fixing brackets 2 pcs.(including four M8 bolts), Cable accessory 1pc. (For communication cable)	
Weight*9		kg	

*1 Use fluid that fulfills the conditions below as the circulating fluid. Tap water: please refer to "Specific Product Precautions". Deionized (pure) water: Electric conductivity 0.4 μS/cm or higher (Electric resistivity 2.5 MΩ·cm or lower)

*2 ① Ambient temperature: 25°C, ② Circulating fluid: Tap water, ③ Circulating fluid temperature: CH1 20°C/CH2 25°C, ④ Circulating fluid flow rate: Rated flow, ⑤ Power supply: 200 VAC

*3 ① Ambient temperature: 25°C, ② Circulating fluid: Tap water, ③ Circulating fluid flow rate: Rated flow, ④ Power supply: 200 VAC

*4 ① Ambient temperature: 25°C, ② Circulating fluid: Tap water, ③ Circulating fluid temperature: CH1 20°C/CH2 25°C, ④ Circulating fluid flow rate: Rated flow, ⑤ Power supply: 200 VAC, ⑥ Piping length: Shortest, ⑦ Load: Same as the cooling capacity

*5 When circulating fluid outlet port pressure = 0.21/0.29 MPa (50/60 Hz)

*6 Fluid flow rate to maintain the cooling capacity. If the actual flow rate is lower than this, install a bypass piping.

*7 Front 1 m/Height 1 m.

*8 The anchor bolt fixing brackets are used for fixing to wooden skids when packaging the thermo-chiller. No anchor bolt is included.

*9 Weight when the circulating fluid is not included.

Thermo-chiller Compact Dual/Basic Type for Lasers

3-phase 200 VAC (50 Hz)

3-phase 200 to 230 VAC (60 Hz)

HRLE Series



How to Order

Air-cooled refrigeration

HRLE 090 - A - 20 - □

Cooling capacity

	CH1, 2 total
090	9.5 kW

Cooling method

A	Air-cooled refrigeration
---	--------------------------

Power supply

20	3-phase 200 VAC (50 Hz)
	3-phase 200 to 230 VAC (60 Hz)

Option

Nil	None
C	With inverter for compressor
M	Deionized water (Pure water) piping
P	With inverter for pump

• When multiple options are combined, indicate the symbols in alphabetical order.

Specifications

Model		HRLE090-A-20			
Cooling method		Air-cooled refrigeration			
Refrigerant		R410A (HFC)			
Refrigerant charge		kg	2		
Control method		PID control			
Ambient temperature		°C	2 to 45		
Circulating fluid system	Circulating fluid*1		Tap water, Deionized (pure) water		
	Set temperature range		°C	CH1: 15 to 25, CH2: CH1 + 0 to 15	
	Cooling capacity (CH1, 2 total) 50/60 Hz*2,*10		kW	8.0/9.5	
	Heating capacity (CH1, 2 total) 50/60 Hz*3		kW	2.0/2.5	
	Temperature stability*4		°C	CH1: ±0.1, CH2: ±0.5	
	Pump capacity	Rated flow 50/60 Hz*5,*11		L/min	CH1: 25/35 (0.5 MPa), CH2: 2/2 (0.5 MPa)
		Max. flow rate 50/60 Hz*11		L/min	55/65
		Max. pump head		m	50
	Settable pressure range (-P)		MPa	0.1 to 0.5	
	Min. operating flow rate 50/60 Hz*6		L/min	CH1: 25/35 (-P: 15), CH2: 1/1	
	Tank capacity (CH1, 2 total)		L	Approx. 18	
Circulating fluid outlet, Circulating fluid return port		CH1: Rc1, CH2: Rc1/2			
Tank drain port		Rc1/4			
Fluid contact material		Stainless steel, Copper (Heat exchanger brazing), Bronze (Pump), Ceramic, Carbon, FKM, PP, PE, POM, PVC, PA, EPDM			
Fluid contact material (-M)		Stainless steel (Heat exchanger brazing), SiC, Carbon, FKM, PP, PE, POM, PVC, PA, EPDM, PTFE			
Electrical system	Power supply		3-phase 200 VAC (50 Hz) Allowable voltage range ±10% (No continuous voltage fluctuation) 3-phase 200 to 230 VAC (60 Hz) Allowable voltage range ±10% (No continuous voltage fluctuation)		
	Earth leakage breaker (Standard)	Rated current	A	30	
		Sensitivity current	mA	30	
	Rated operating current 50/60 Hz		A	14/17	
	Rated power consumption 50/60 Hz		kW(kVA)	4.3/5.3 (4.9/5.8)	
Communication function		Contact input/output, Serial communication (RS-485)			
Noise level*7		dB(A)	65		
Accessories*8		Operation Manual (for installation/operation) 2 copies (English 1 pc./Japanese 1 pc.), Anchor bolt fixing brackets 2 pcs. (including four M8 bolts), Cable accessory (For communication cable)			
Weight*9,*12		kg	140		

- *1 Use fluid that fulfills the conditions below as the circulating fluid.
Tap water: please refer to "Specific Product Precautions".
Deionized (pure) water: Electric conductivity 0.4 μS/cm or higher (Electric resistivity 2.5 MΩ·cm or lower)
- *2 ① Ambient temperature: 32°C, ② Circulating fluid: Tap water, ③ Circulating fluid temperature: CH1 20°C/CH2 25°C, ④ Circulating fluid flow rate: Rated flow, ⑤ Power supply: 200 VAC
- *3 ① Ambient temperature: 32°C, ② Circulating fluid: Tap water, ③ Circulating fluid flow rate: Rated flow, ④ Power supply: 200 VAC
- *4 ① Ambient temperature: 32°C, ② Circulating fluid: Tap water, ③ Circulating fluid temperature: CH1 20°C/CH2 25°C, ④ Circulating fluid flow rate: Rated flow, ⑤ Power supply: 200 VAC, ⑥ Piping length: Shortest, ⑦ Load: Same as the cooling capacity

- *5 Circulating fluid temperature: CH1: 20°C/CH2: 25°C at the device outlet.
- *6 Fluid flow rate to maintain the cooling capacity. If the actual flow rate is lower than this, install a bypass piping.
- *7 Front 1 m/Height 1 m.
- *8 The anchor bolt fixing brackets (including four M8 bolts) are used for fixing to wooden skids when packaging the thermo-chiller. No anchor bolt is included.
- *9 Weight when the circulating fluid is not included.
- *10 The capacity is 60 Hz even in the 50 Hz area when option C is selected.
- *11 The capacity is 60 Hz even in the 50 Hz area when option P is selected.
- *12 The weight will increase by 4 kg when option C and P is selected.

Thermo-chiller Compact Dual/Basic Type for Lasers

Single-phase 200 to 230 VAC (50/60 Hz)

HRLE Series



How to Order

Water-cooled refrigeration

HRLE 050-W-20-

Cooling capacity	
	CH1, 2 total
050	5 kW

Cooling method	
W	Water-cooled refrigeration

Power supply	
20	Single-phase 200 to 230 VAC (50/60 Hz)

Option	
Nil	None
M	Deionized water (Pure water) piping

• Options "C" and "P" are not available for the HRLE050.



Specifications

Model		HRLE050-W-20		
Cooling method		Water-cooled refrigeration		
Refrigerant		R410A (HFC)		
Refrigerant charge		kg 1.2		
Control method		PID control		
Ambient temperature		°C 2 to 45		
Circulating fluid system	Circulating fluid*1		Tap water, Deionized (pure) water	
	Set temperature range		°C CH1: 15 to 25, CH2: CH1 + 0 to 15	
	Cooling capacity (CH1, 2 total) 50/60 Hz*2		kW 4.8/5.8	
	Heating capacity (CH1, 2 total) 50/60 Hz*3		kW 1.2/1.5	
	Temperature stability*4		°C CH1: ±0.1, CH2: ±0.5	
	Pump capacity	Rated flow 50/60 Hz*5	L/min	CH1: 21/26, CH2: 2/2
		Max. flow rate 50/60 Hz	L/min	29/38
		Max. pump head 50/60 Hz	m	34/50
	Min. operating flow rate 50/60 Hz*6		L/min	CH1: 15/15, CH2: 1/1
	Tank capacity (CH1, 2 total)		L	Approx. 18
Circulating fluid outlet, Circulating fluid return port		CH1: Rc1/2, CH2: Rc1/2		
Tank drain port		Rc1/4		
Fluid contact material		Stainless steel, Copper (Heat exchanger brazing), Bronze (Pump), Ceramic, Carbon, FKM, PP, PE, POM, PVC, PA, EPDM		
Fluid contact material (-M)		Stainless steel (Heat exchanger brazing), SiC, Carbon, FKM, PP, PE, POM, PVC, PA, EPDM, PTFE		
Facility water system	Temperature range		°C 5 to 40	
	Pressure range		MPa 0.3 to 0.5	
	Required flow 50/60 Hz*7		L/min 16	
	Facility water pressure differential		MPa 0.3 or more	
	Facility water inlet/outlet		Rc1/2	
Fluid contact material		Stainless steel, Copper (Heat exchanger brazing), Brass, PTFE, NBR, EPDM		
Electrical system	Power supply		Single-phase 200 to 230 VAC (50/60 Hz) Allowable voltage range ±10% (No continuous voltage fluctuation)	
	Earth leakage breaker (Standard)	Rated current	A 30	
		Sensitivity current	mA 30	
	Rated operating current 50/60 Hz		A 10.9/12.7	
	Rated power consumption 50/60 Hz		kW(kVA) 2.0/2.4 (2.1/2.5)	
Communication function		Contact input/output, Serial communication (RS-485)		
Noise level*8 50/60 Hz		dB(A) 62/64		
Accessories*9		Operation Manual (for installation/operation) 2 copies (English 1 pc./Japanese 1 pc.), Anchor bolt fixing brackets 2 pcs.(including four M8 bolts), Cable accessory 1 pc. (For communication cable)		
Weight*10		kg 107		

*1 Use fluid that fulfills the conditions below as the circulating fluid.
Tap water: please refer to "Specific Product Precautions".
Deionized (pure) water: Electric conductivity 0.4 μS/cm or higher (Electric resistivity 2.5 MΩ·cm or lower)

*2 ① Facility water temperature: 25°C, ② Circulating fluid: Tap water, ③ Circulating fluid temperature: CH1 20°C/CH2 25°C, ④ Circulating fluid flow rate: Rated flow, ⑤ Power supply: 200 VAC

*3 ① Facility water temperature: 25°C, ② Circulating fluid: Tap water, ③ Circulating fluid flow rate: Rated flow, ④ Power supply: 200 VAC

*4 ① Facility water temperature: 25°C, ② Circulating fluid: Tap water, ③ Circulating fluid temperature: CH1 20°C/CH2 25°C, ④ Circulating fluid flow rate: Rated flow, ⑤ Power supply: 200 VAC, ⑥ Piping length: Shortest, ⑦ Load: Same as the cooling capacity

*5 When circulating fluid outlet port pressure = 0.21/0.29 MPa (50/60 Hz)

*6 Fluid flow rate to maintain the cooling capacity. If the actual flow rate is lower than this, install a bypass piping.

*7 The required flow rate when the cooling capacity load is applied at a circulating fluid temperature of 20°C, and circulating fluid rated flow and facility water temperature of 25°C. The actual facility water flow rate will vary depending on the operating conditions.

*8 Front 1 m/Height 1 m.

*9 The anchor bolt fixing brackets are used for fixing to wooden skids when packaging the thermo-chiller. No anchor bolt is included.

*10 Weight when the circulating fluid is not included.

Thermo-chiller Compact Dual/Basic Type for Lasers

3-phase 200 VAC (50 Hz)

3-phase 200 to 230 VAC (60 Hz)

HRLE Series



How to Order

Water-cooled refrigeration

HRLE 090-W-20-

Cooling capacity	
	CH1, 2 total
090	9.5 kW

Cooling method	
W	Water-cooled refrigeration

Power supply	
20	3-phase 200 VAC (50 Hz)
	3-phase 200 to 230 VAC (60 Hz)

Option	
Nil	None
C	With inverter for compressor
M	Deionized water (Pure water) piping
P	With inverter for pump

• When multiple options are combined, indicate the symbols in alphabetical order.



Specifications

Model		HRLE090-W-20			
Cooling method		Water-cooled refrigeration			
Refrigerant		R410A (HFC)			
Refrigerant charge		kg	1.9		
Control method		PID control			
Ambient temperature		°C	2 to 45		
Circulating fluid system	Circulating fluid*1		Tap water, Deionized (pure) water		
	Set temperature range		°C	CH1: 15 to 25, CH2: CH1 + 0 to 15	
	Cooling capacity (CH1, 2 total) 50/60 Hz*2,*10		kW	9.5/11.0	
	Heating capacity (CH1, 2 total) 50/60 Hz*3		kW	2.0/2.5	
	Temperature stability*4		°C	CH1: ±0.1, CH2: ±0.5	
	Pump capacity	Rated flow 50/60 Hz*5,*11		L/min	CH1: 25/35 (0.5 MPa), CH2: 2/2 (0.5 MPa)
		Max. flow rate 50/60 Hz*11		L/min	55/65
		Max. pump head		m	50
	Settable pressure range (-P)		MPa	0.1 to 0.5	
	Min. operating flow rate 50/60 Hz*6		L/min	CH1: 25/35 (-P: 15), CH2: 1/1	
	Tank capacity (CH1, 2 total)		L	Approx. 18	
	Circulating fluid outlet, Circulating fluid return port		CH1: Rc1, CH2: Rc1/2		
Tank drain port		Rc1/4			
Fluid contact material		Stainless steel, Copper (Heat exchanger brazing), Bronze (Pump), Ceramic, Carbon, FKM, PP, PE, POM, PVC, PA, EPDM			
Fluid contact material (-M)		Stainless steel (Heat exchanger brazing), SiC, Carbon, FKM, PP, PE, POM, PVC, PA, EPDM, PTFE			
Facility water system	Temperature range		°C	5 to 40	
	Pressure range		MPa	0.3 to 0.5	
	Required flow 50/60 Hz		L/min	25/25	
	Facility water pressure differential		MPa	0.3 or more	
	Facility water inlet/outlet		Rc1/2		
Fluid contact material		Stainless steel, Copper (Heat exchanger brazing), Brass, PTFE, NBR, EPDM			
Electrical system	Power supply		3-phase 200 VAC (50 Hz) Allowable voltage range ±10% (No continuous voltage fluctuation) 3-phase 200 to 230 VAC (60 Hz) Allowable voltage range ±10% (No continuous voltage fluctuation)		
	Earth leakage breaker (Standard)	Rated current		A	30
		Sensitivity current		mA	30
	Rated operating current 50/60 Hz		A	13.5/14.4	
	Rated power consumption 50/60 Hz		kW(kVA)	3.5/4.4 (4.7/5.0)	
	Communication function		Contact input/output, Serial communication (RS-485)		
Noise level*7		dB(A)	65		
Accessories*8		Operation Manual (for installation/operation) 2 copies (English 1 pc./Japanese 1 pc.), Anchor bolt fixing brackets 2 pcs.(including four M8 bolts), Cable accessory 1 pc.(For communication cable)			
Weight*9,*12		kg	134		

*1 Use fluid that fulfills the conditions below as the circulating fluid.
Tap water: please refer to "Specific Product Precautions".
Deionized (pure) water: Electric conductivity 0.4 μS/cm or higher (Electric resistivity 2.5 MΩ·cm or lower)

*2 ① Ambient temperature: 32°C, ② Circulating fluid: Tap water, ③ Circulating fluid temperature: CH1 20°C/CH2 25°C, ④ Circulating fluid flow rate: Rated flow, ⑤ Power supply: 200 VAC

*3 ① Ambient temperature: 32°C, ② Circulating fluid: Tap water, ③ Circulating fluid flow rate: Rated flow, ④ Power supply: 200 VAC

*4 ① Ambient temperature: 32°C, ② Circulating fluid: Tap water, ③ Circulating fluid temperature: CH1 20°C/CH2 25°C, ④ Circulating fluid flow rate: Rated flow, ⑤ Power supply: 200 VAC, ⑥ Piping length: Shortest, ⑦ Load: Same as the cooling capacity

*5 Circulating fluid temperature: CH1 : 20°C/CH2 : 25°C at the device outlet.

*6 Fluid flow rate to maintain the cooling capacity. If the actual flow rate is lower than this, install a bypass piping.

*7 Front 1 m/Height 1 m.

*8 The anchor bolt fixing brackets (including four M8 bolts) are used for fixing to wooden skids when packaging the thermo-chiller. No anchor bolt is included.

*9 Weight when the circulating fluid is not included.

*10 The capacity is 60 Hz even in the 50 Hz area when option C is selected.

*11 The capacity is 60 Hz even in the 50 Hz area when option P is selected.

*12 The weight will increase by 4 kg when option C and P is selected.

*13 The actual facility water flow rate will vary depending on the operating conditions.

Thermo-chiller Compact Dual/Basic Type for Lasers

3-phase 380 to 415 VAC (50/60 Hz)

3-phase 460 to 480 VAC (60 Hz)

HRLE Series



Scheduled to acquire UL Standards



How to Order

Air-cooled refrigeration

HRLE 090 - A - 40 - []

Cooling capacity

	CH1, 2 total
090	9.5 kW

Cooling method

A	Air-cooled refrigeration
---	--------------------------

Power supply

40	3-phase 380 to 415 VAC (50/60 Hz) 3-phase 460 to 480 VAC (60 Hz)
----	---

Option

Nil	None
C	With inverter for compressor
M	Deionized water (Pure water) piping
P	With inverter for pump

Air-cooled refrigeration

• When multiple options are combined, indicate the symbols in alphabetical order.

Specifications

Model		HRLE090-A-40		
Cooling method		Air-cooled refrigeration		
Refrigerant		R410A (HFC)		
Refrigerant charge		kg	2	
Control method		PID control		
Ambient temperature		°C	2 to 45	
Circulating fluid system	Circulating fluid*1		Tap water, Deionized (pure) water	
	Set temperature range		°C CH1: 15 to 25, CH2: CH1 + 0 to 15	
	Cooling capacity (CH1, 2 total) 50/60 Hz*2,*11		kW 8.0/9.5	
	Heating capacity (CH1, 2 total) 50/60 Hz*3		kW 2.0/2.5	
	Temperature stability*4		°C CH1: ±0.1, CH2: ±0.5	
	Pump capacity	Rated flow 50/60 Hz*5,*12	L/min	CH1: 25/35 (0.5 MPa), CH2: 2/2 (0.5 MPa)
		Max. flow rate 50/60 Hz*12	L/min	55/65
		Max. pump head	m	50
	Settable pressure range (-P)		MPa	0.1 to 0.5
	Min. operating flow rate 50/60 Hz*6		L/min	CH1: 25/35 (-P: 15), CH2: 1/1
Tank capacity (CH1, 2 total)		L	Approx. 18	
Circulating fluid outlet, Circulating fluid return port		CH1: Rc1, CH2: Rc1/2		
Tank drain port		Rc1/4		
Fluid contact material		Stainless steel, Copper (Heat exchanger brazing), Bronze (Pump), Ceramic, Carbon, FKM, PP, PE, POM, PVC, PA, EPDM		
Fluid contact material (-M)		Stainless steel (Heat exchanger brazing), SiC, Carbon, FKM, PP, PE, POM, PVC, PA, EPDM, PTFE		
Electrical system	Power supply		3-phase 380 to 415 VAC (50/60 Hz) Allowable voltage range ±10% (No continuous voltage fluctuation) 3-phase 460 to 480 VAC (60 Hz) Allowable voltage range +4%, -10% (Max. voltage less than 500 V and no continuous voltage fluctuation)	
	Applicable earth leakage breaker*7	Rated current	A 20	
		Sensitivity current	mA 30	
	Rated operating current 50/60 Hz		A 6.8/8.2	
	Rated power consumption 50/60 Hz		kW(kVA) 4.3/5.3 (4.9/5.8)	
Communication function		Contact input/output, Serial communication (RS-485)		
Noise level*8		dB(A)	67	
Accessories*9		Operation Manual (for installation/operation) 2 copies (English 1 pc./Japanese 1 pc.), Anchor bolt fixing brackets 2 pcs.(including four M8 bolts), Cable accessory (For communication cable)		
Weight*10,*13		kg	140	

*1 Use fluid that fulfills the conditions below as the circulating fluid.
Tap water: please refer to "Specific Product Precautions".
Deionized (pure) water: Electric conductivity 0.4 μS/cm or higher (Electric resistivity 2.5 MΩ·cm or lower)

*2 ① Ambient temperature: 32°C, ② Circulating fluid: Tap water, ③ Circulating fluid temperature: CH1 20°C/CH2 25°C, ④ Circulating fluid flow rate: Rated flow, ⑤ Power supply: 400 VAC

*3 ① Ambient temperature: 32°C, ② Circulating fluid: Tap water, ③ Circulating fluid flow rate: Rated flow, ④ Power supply: 400 VAC

*4 ① Ambient temperature: 32°C, ② Circulating fluid: Tap water, ③ Circulating fluid temperature: CH1 20°C/CH2 25°C, ④ Circulating fluid flow rate: Rated flow, ⑤ Power supply: 400 VAC, ⑥ Piping length: Shortest, ⑦ Load: Same as the cooling capacity

*5 Circulating fluid temperature: CH1 : 20°C/CH2 : 25°C at the device outlet.

*6 Fluid flow rate to maintain the cooling capacity. If the actual flow rate is lower than this, install a bypass piping.

*7 To be prepared by the user.

*8 Front 1 m/Height 1 m.

*9 The anchor bolt fixing brackets (including four M8 bolts) are used for fixing to wooden skids when packaging the thermo-chiller. No anchor bolt is included.

*10 Weight when the circulating fluid is not included.

*11 The capacity is 60 Hz even in the 50 Hz area when option C is selected.

*12 The capacity is 60 Hz even in the 50 Hz area when option P is selected.

*13 The weight will increase by 4 kg when option C and P is selected.

Thermo-chiller Compact Dual/Basic Type for Lasers

3-phase 380 to 415 VAC (50/60 Hz)

3-phase 460 to 480 VAC (60 Hz)

HRLE Series



Scheduled to acquire UL Standards



How to Order

Water-cooled refrigeration

HRLE 090-W-40-

Cooling capacity	
	CH1, 2 total
090	9.5 kW

Cooling method	
W	Water-cooled refrigeration

Power supply	
40	3-phase 380 to 415 VAC (50/60 Hz) 3-phase 460 to 480 VAC (60 Hz)

Option	
Nil	None
C	With inverter for compressor
M	Deionized water (Pure water) piping
P	With inverter for pump

• When multiple options are combined, indicate the symbols in alphabetical order.



Specifications

Model		HRLE090-W-40		
Cooling method		Water-cooled refrigeration		
Refrigerant		R410A (HFC)		
Refrigerant charge		kg	1.9	
Control method		PID control		
Ambient temperature		°C	2 to 45	
Circulating fluid system	Circulating fluid*1		Tap water, Deionized (pure) water	
	Set temperature range		°C	CH1: 15 to 25, CH2: CH1 + 0 to 15
	Cooling capacity (CH1, 2 total) 50/60 Hz*2,*11		kW	9.5/11.0
	Heating capacity (CH1, 2 total) 50/60 Hz*3		kW	2.0/2.5
	Temperature stability*4		°C	CH1: ±0.1, CH2: ±0.5
	Pump capacity	Rated flow 50/60 Hz*5,*12	L/min	CH1: 25/35 (0.5 MPa), CH2: 2/2 (0.5 MPa)
		Max. flow rate 50/60 Hz*12	L/min	55/65
		Max. pump head	m	50
	Settable pressure range (-P)		MPa	0.1 to 0.5
	Min. operating flow rate 50/60 Hz*6		L/min	CH1: 25/35 (-P: 15), CH2: 1/1
	Tank capacity (CH1, 2 total)		L	Approx. 18
Circulating fluid outlet, Circulating fluid return port		CH1: Rc1, CH2: Rc1/2		
Tank drain port		Rc1/4		
Fluid contact material		Stainless steel, Copper (Heat exchanger brazing), Bronze (Pump), Ceramic, Carbon, FKM, PP, PE, POM, PVC, PA, EPDM		
Fluid contact material (-M)		Stainless steel (Heat exchanger brazing), SiC, Carbon, FKM, PP, PE, POM, PVC, PA, EPDM, PTFE		
Facility water system	Temperature range		°C	5 to 40
	Pressure range		MPa	0.3 to 0.5
	Required flow 50/60 Hz		L/min	25/25
	Facility water pressure differential		MPa	0.3 or more
	Facility water inlet/outlet		Rc1/2	
Fluid contact material		Stainless steel, Copper (Heat exchanger brazing), Brass, PTFE, NBR, EPDM		
Electrical system	Power supply		3-phase 380 to 415 VAC (50/60 Hz) Allowable voltage range ±10% (No continuous voltage fluctuation) 3-phase 460 to 480 VAC (60 Hz) Allowable voltage range +4%, -10% (Max. voltage less than 500 V and no continuous voltage fluctuation)	
	Applicable earth leakage breaker*7	Rated current	A	20
		Sensitivity current	mA	30
	Rated operating current 50/60 Hz		A	6.7/7.1
	Rated power consumption 50/60 Hz		kW(kVA)	3.5/4.4 (4.7/5.0)
Communication function		Contact input/output, Serial communication (RS-485)		
Noise level*8		dB(A)	65	
Accessories*9		Operation Manual (for installation/operation) 2 copies (English 1 pc./Japanese 1 pc.), Anchor bolt fixing brackets 2 pcs.(including four M8 bolts), Cable accessory 1 pc. (For communication cable)		
Weight*10,*13		kg	134	

*1 Use fluid that fulfills the conditions below as the circulating fluid.
Tap water: please refer to "Specific Product Precautions".
Deionized (pure) water: Electric conductivity 0.4 μS/cm or higher (Electric resistivity 2.5 MΩ·cm or lower)

*2 ① Ambient temperature: 32°C, ② Circulating fluid: Tap water, ③ Circulating fluid temperature: CH1 20°C/CH2 25°C, ④ Circulating fluid flow rate: Rated flow, ⑤ Power supply: 400 VAC

*3 ① Ambient temperature: 32°C, ② Circulating fluid: Tap water, ③ Circulating fluid flow rate: Rated flow, ④ Power supply: 400 VAC

*4 ① Ambient temperature: 32°C, ② Circulating fluid: Tap water, ③ Circulating fluid temperature: CH1 20°C/CH2 25°C, ④ Circulating fluid flow rate: Rated flow, ⑤ Power supply: 400 VAC, ⑥ Piping length: Shortest, ⑦ Load: Same as the cooling capacity

*5 Circulating fluid temperature: CH1 : 20°C/CH2 : 25°C at the device outlet.

*6 Fluid flow rate to maintain the cooling capacity. If the actual flow rate is lower than this, install a bypass piping.

*7 To be prepared by the user.

*8 Front 1 m/Height 1 m.

*9 The anchor bolt fixing brackets (including four M8 bolts) are used for fixing to wooden skids when packaging the thermo-chiller. No anchor bolt is included.

*10 Weight when the circulating fluid is not included.

*11 The capacity is 60 Hz even in the 50 Hz area when option C is selected.

*12 The capacity is 60 Hz even in the 50 Hz area when option P is selected.

*13 The weight will increase by 4 kg when option C and P is selected.

Cooling Capacity

HRLE050-A-20 [50 Hz]

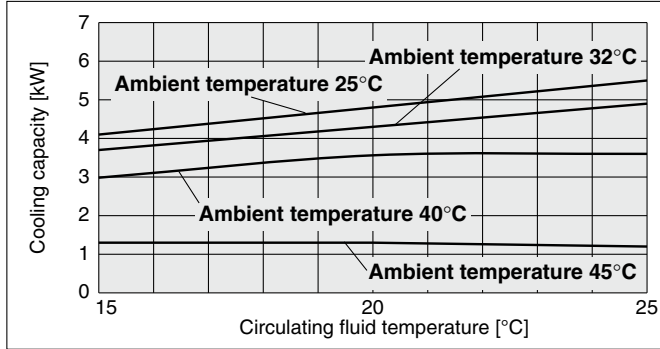

* The cooling capacity is the sum of the capacities of CH1 and CH2.

HRLE050-A-20 [60 Hz]

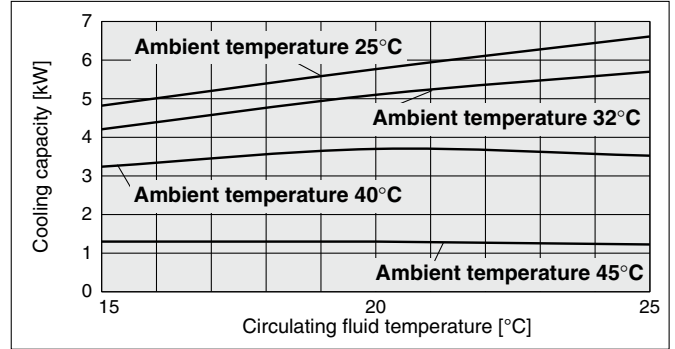

HRLE050-W-20 [50 Hz]

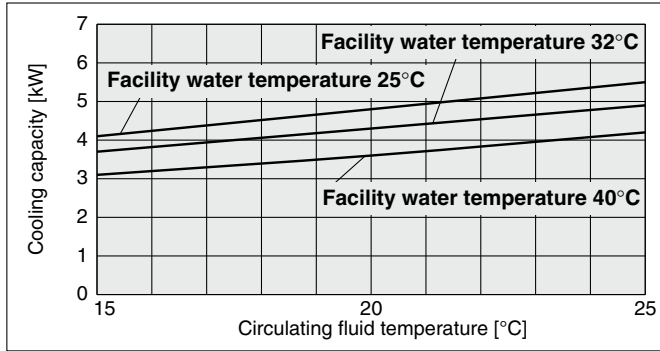

* The cooling capacity is the sum of the capacities of CH1 and CH2.

HRLE050-W-20 [60 Hz]

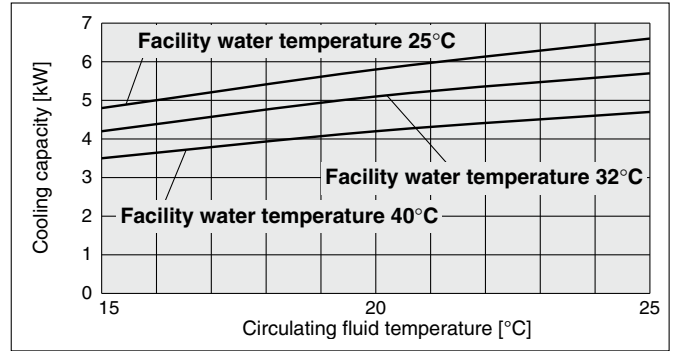

HRLE090-A-20/40 [50 Hz]

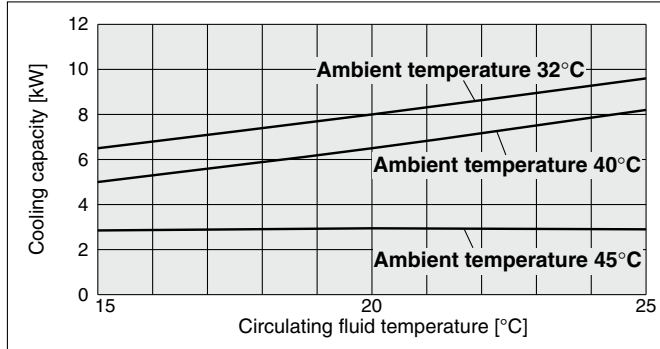

* The cooling capacity is the sum of the capacities of CH1 and CH2.
 * The ambient temperature of 32°C is at 60% fan output (default setting).
 * The ambient temperatures of 40°C and 45°C are at 100% fan output. (The noise level rises by approx. 3 dB(A) from the rated condition.)

HRLE090-A-20/40 [60 Hz]

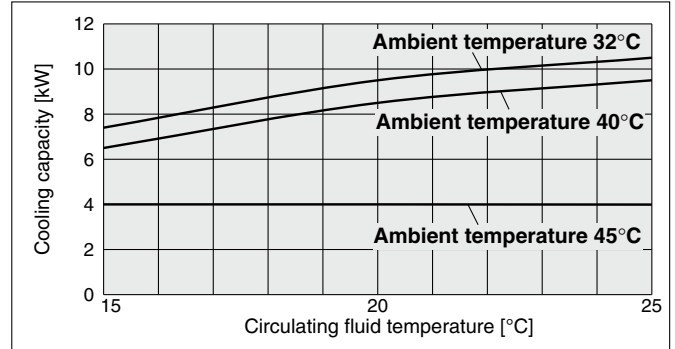

HRLE090-W-20/40 [50 Hz]

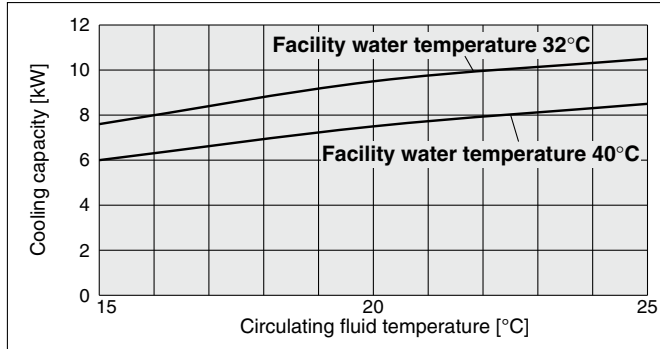

* The cooling capacity is the sum of the capacities of CH1 and CH2.

HRLE090-W-20/40 [60 Hz]

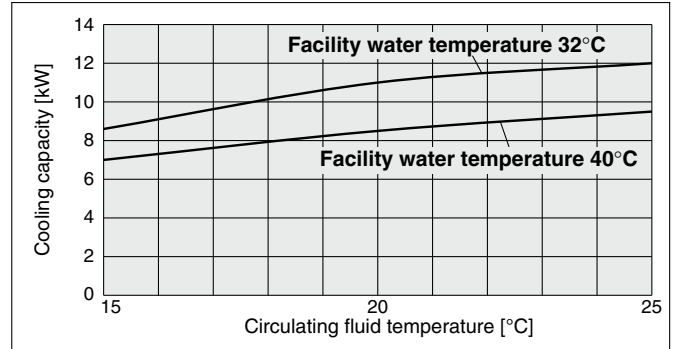

Heating Capacity

HRLE050-A-20 [50 Hz]

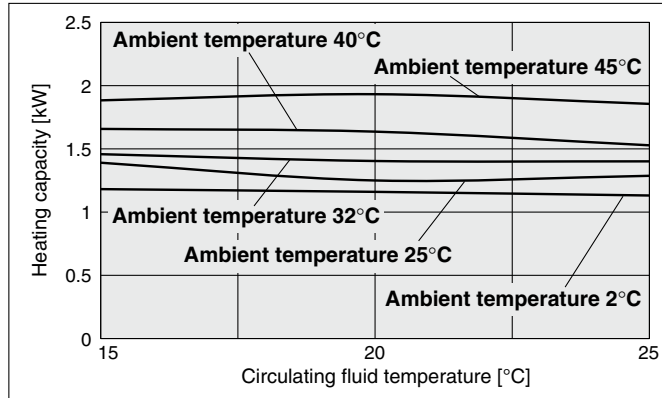

HRLE050-A-20 [60 Hz]

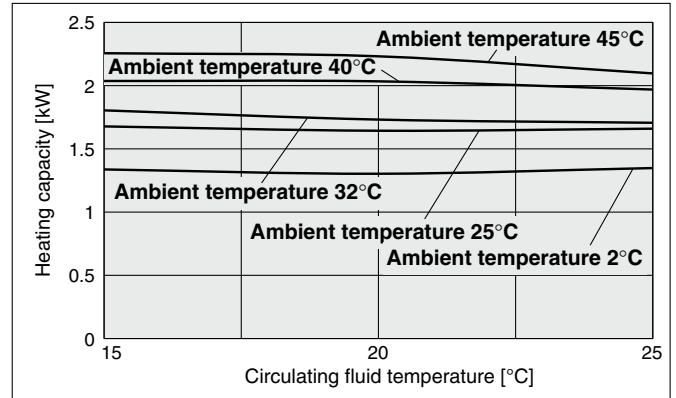

HRLE050-W-20 [50 Hz]

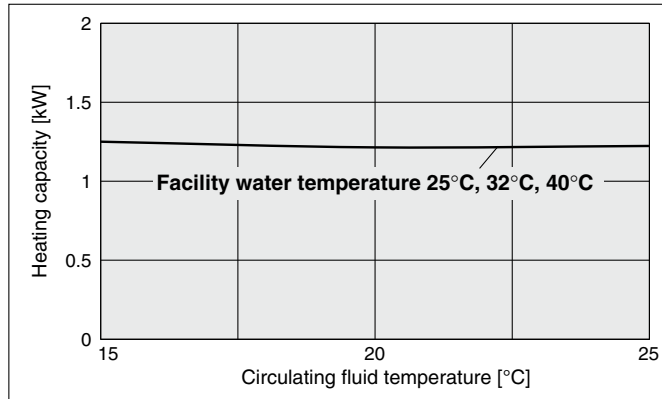

HRLE050-W-20 [60 Hz]

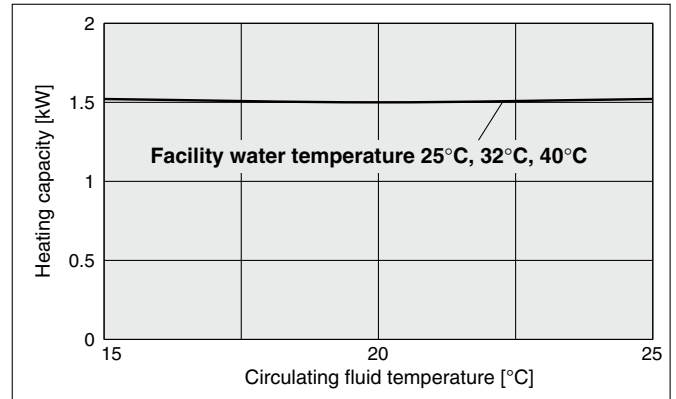

Pump Capacity

HRLE050-□-20

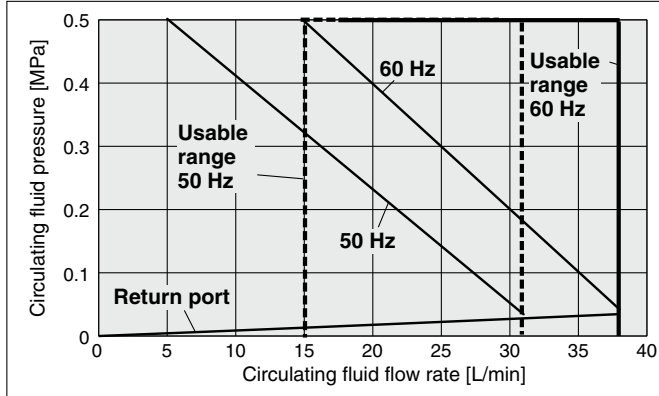

* The pump capacity is the capacity of CH1 when 2 L/min are applied to CH2.

HRLE090-□-20/40

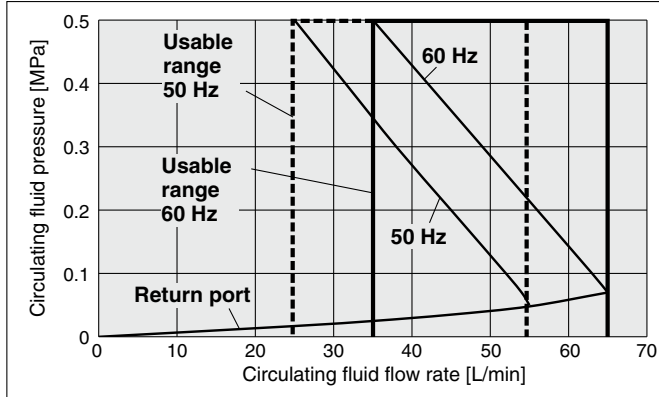

* The pump capacity is the capacity of CH1 when 2 L/min are applied to CH2.

Required Facility Water Flow Rate

HRLE050-W-20

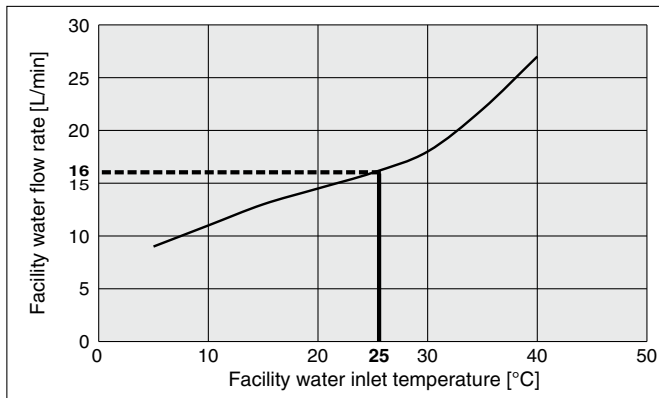

* This is the facility water flow rate at the circulating fluid rated flow and the cooling capacity listed in the "Cooling Capacity" specifications.

⚠ Caution

Mechanical Seal Pump

The pump used for the thermo-chiller HRLE series uses a mechanical seal with the fixed ring and rotary ring used for the shaft seal part. If foreign matter enter the gap between the seals, this may cause a trouble such as leakage from the seal part or pump lock. Therefore, it is strongly recommended to install the particle filter in the return piping of the chiller.

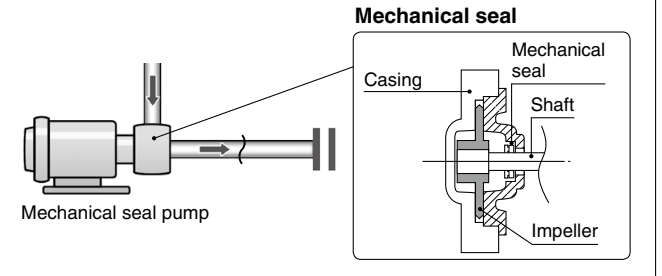

Dimensions

HRLE050-A-20

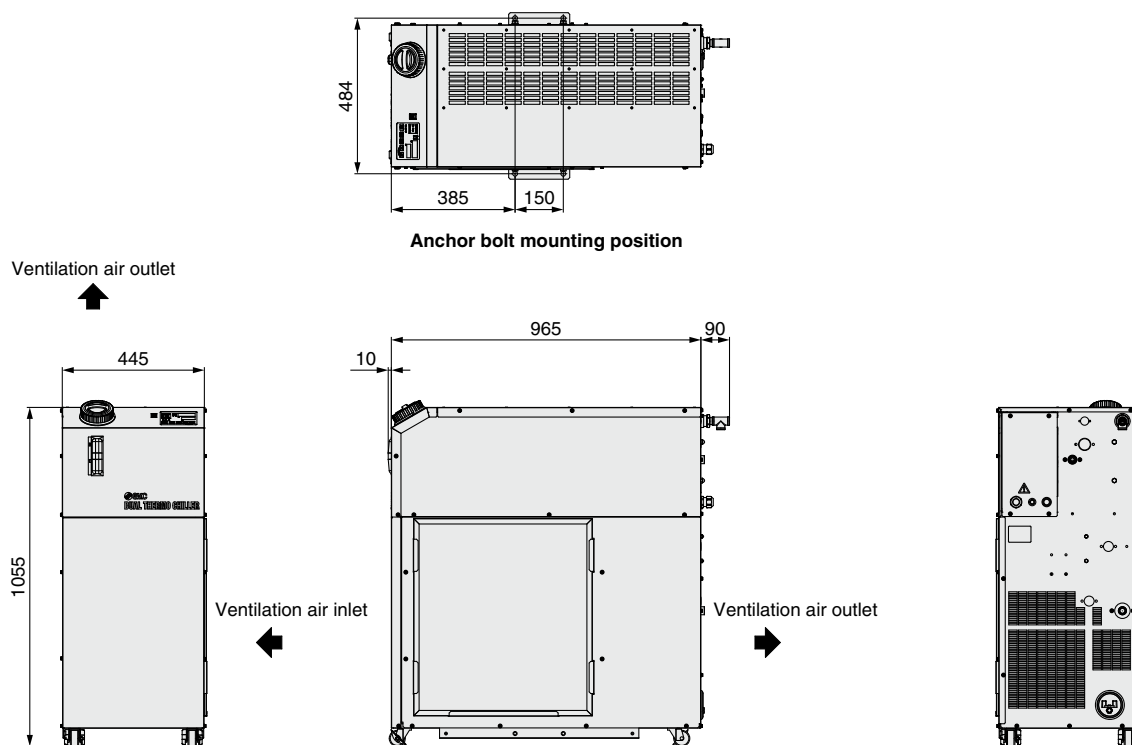

Parts Description

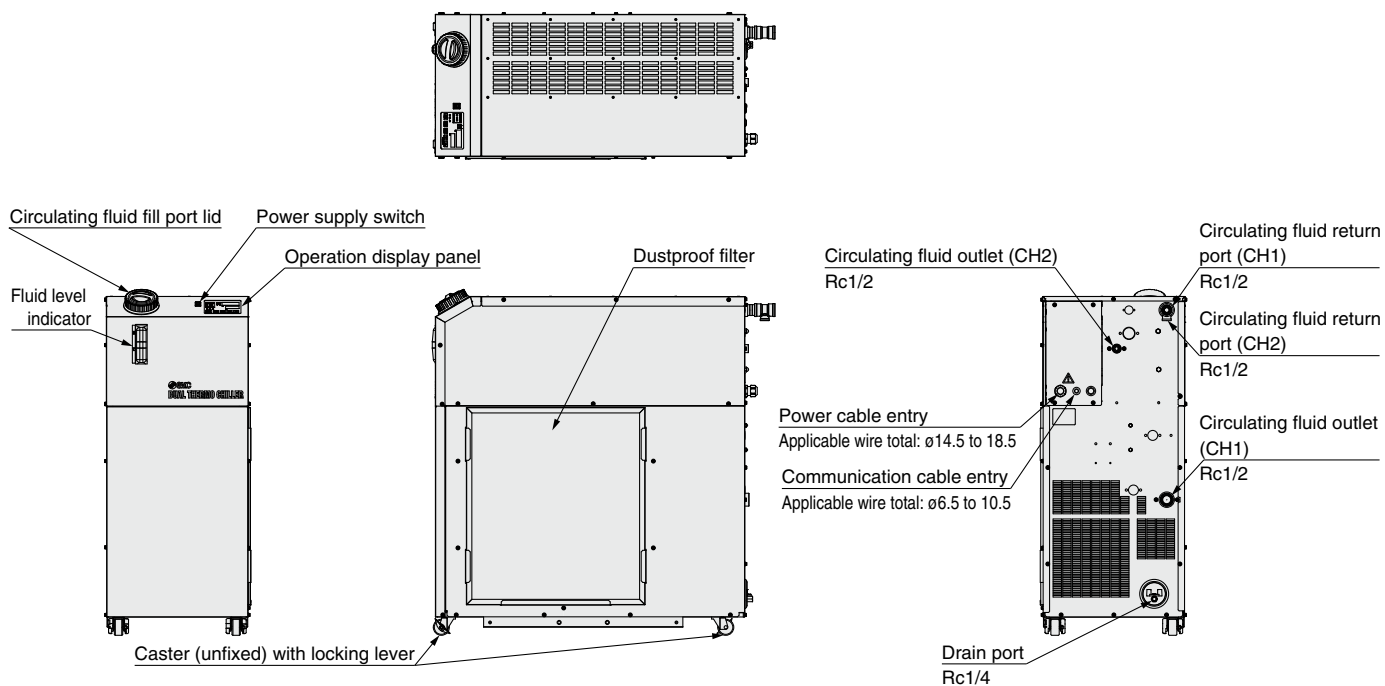

Dimensions

HRLE050-W-20

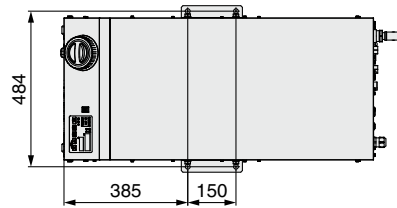

Anchor bolt mounting position

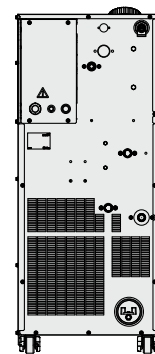
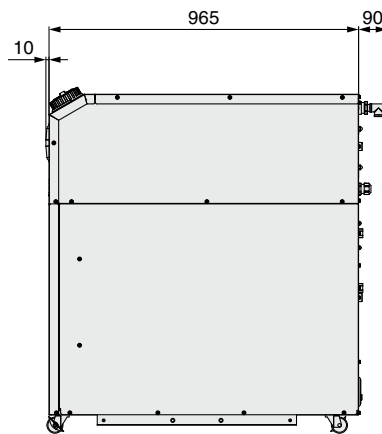
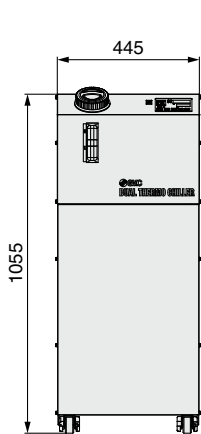

Parts Description

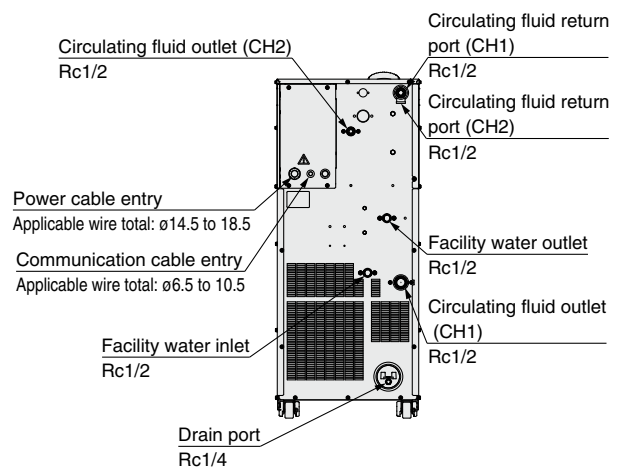
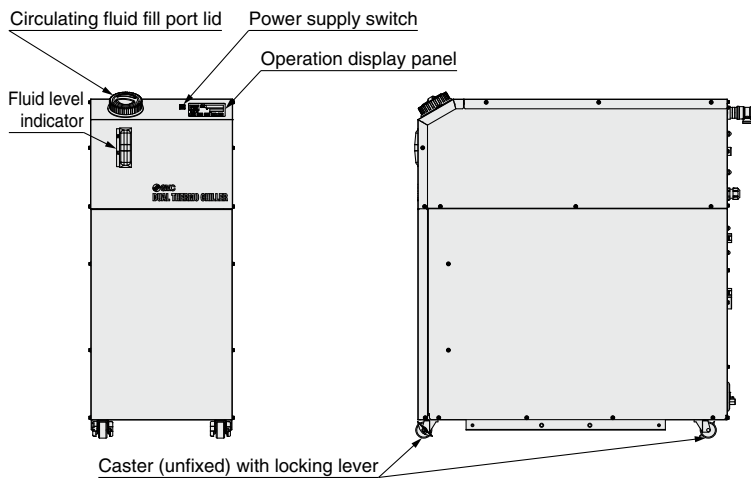
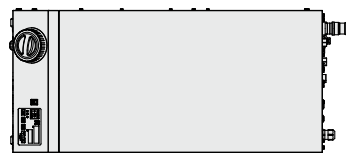

Dimensions

HRLE090-A-20/40

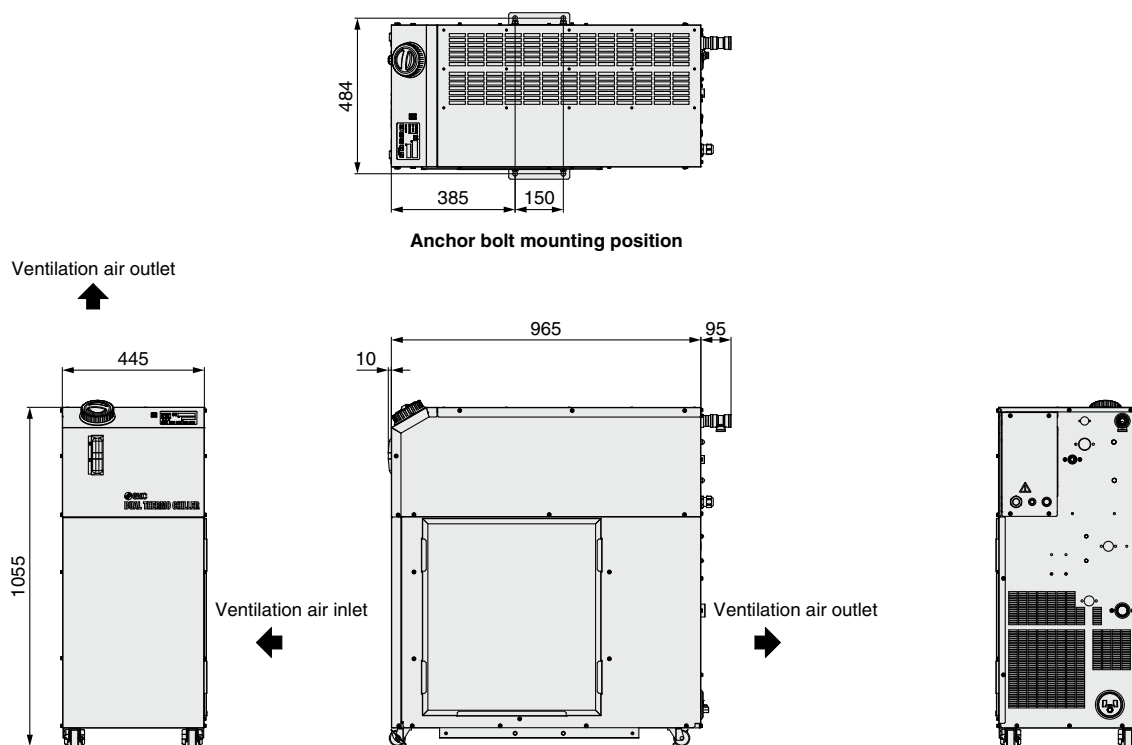

Parts Description

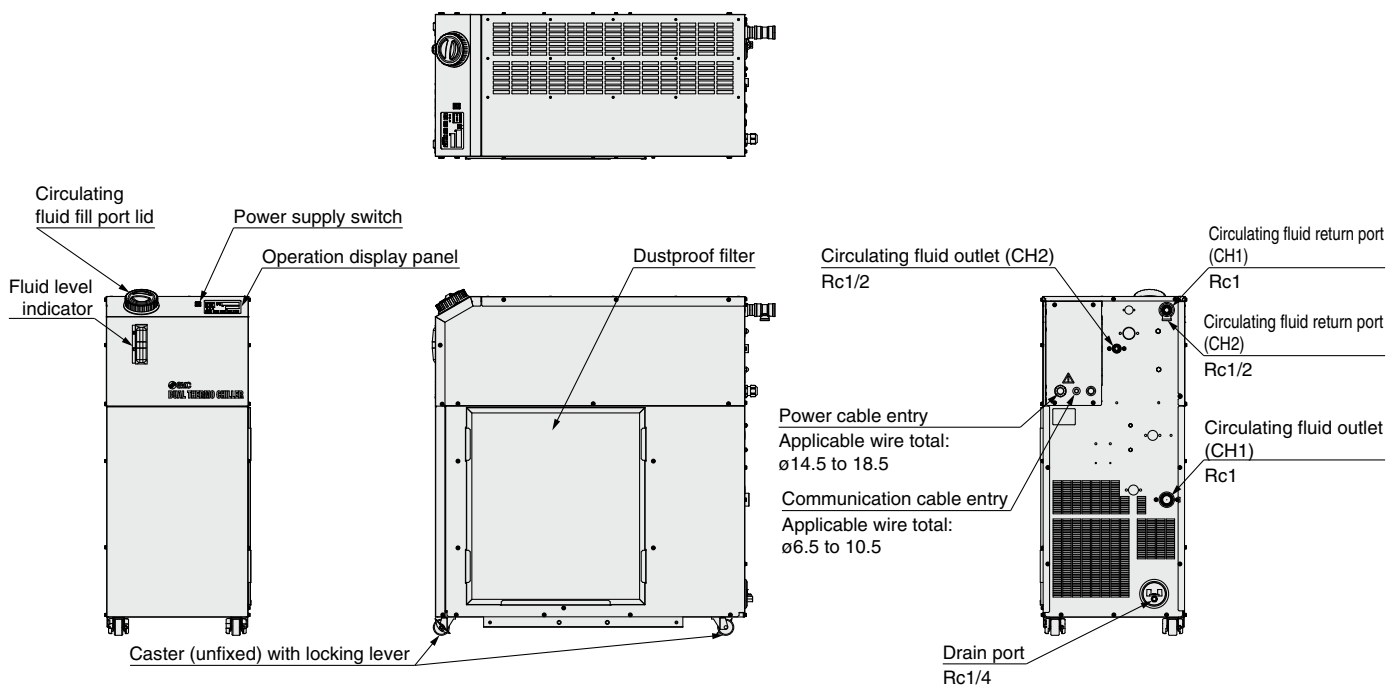

Dimensions

HRLE090-W-20/40

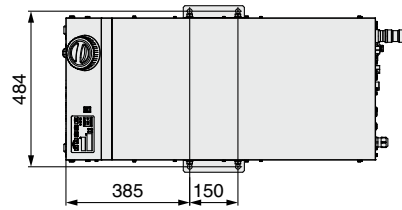

Anchor bolt mounting position

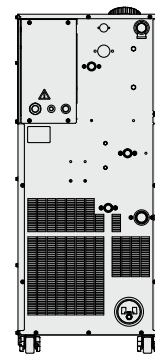
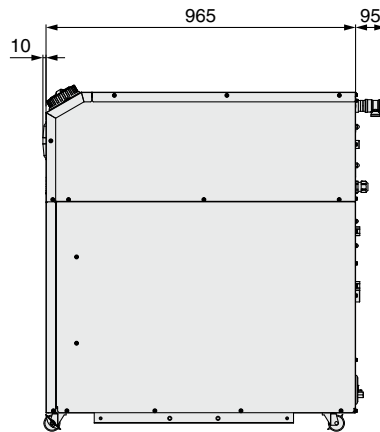
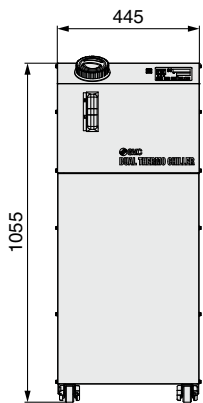

Parts Description

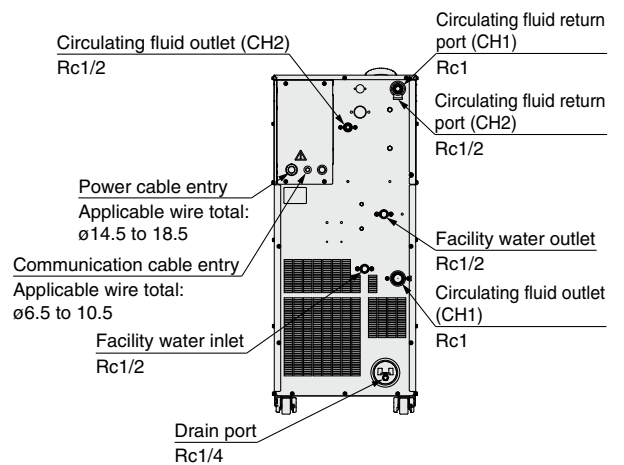
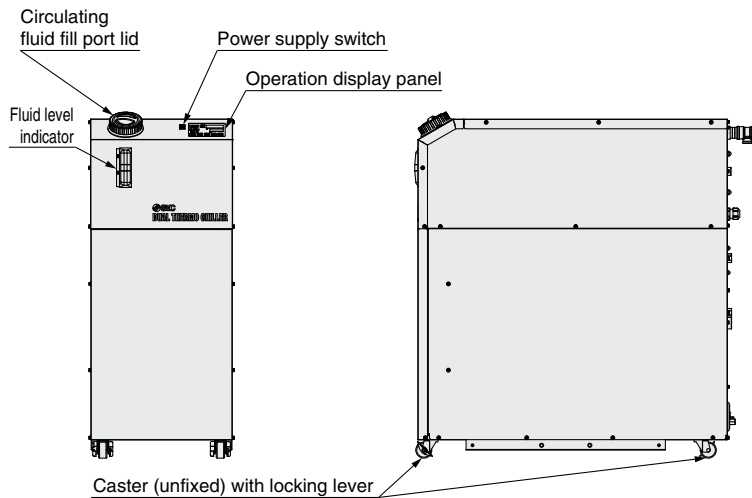

Recommended External Piping Flow

External piping circuit is recommended as shown below.

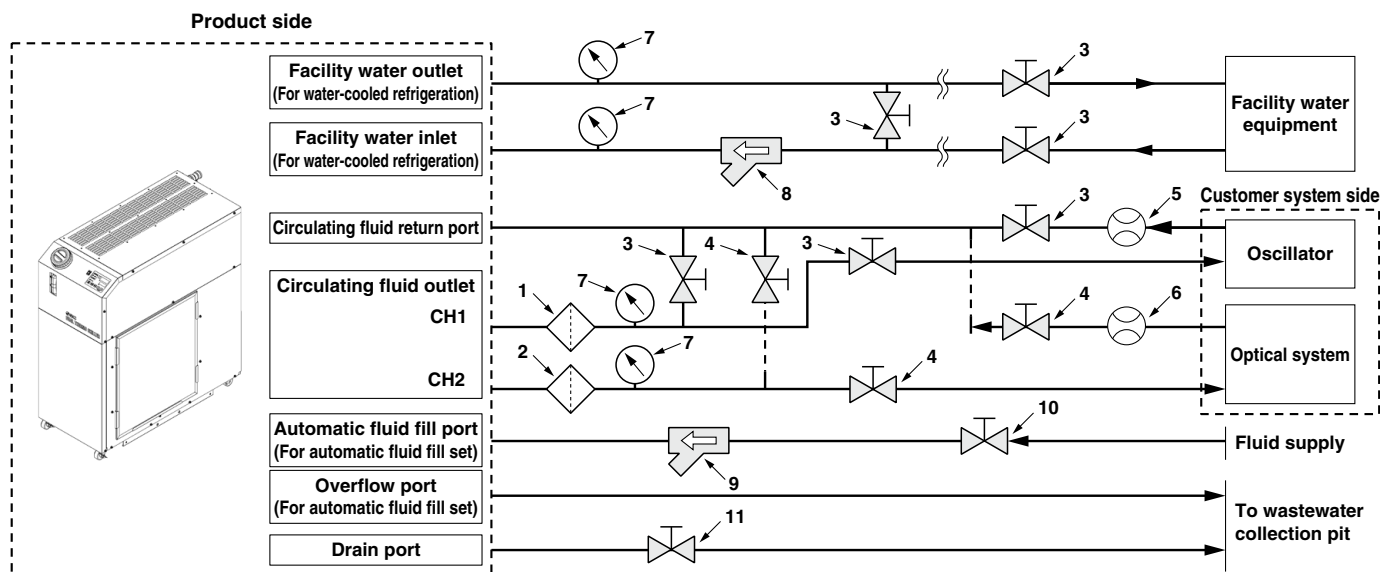

No.	Description	Size	090	050	Note
1	Filter	Rc1 (5 μF)	●	●	The value in () shows the nominal filtration accuracy.
		Rc1/2 (5 μF)	●	●	The value in () shows the nominal filtration accuracy.
2	Filter	Rc1/2 (5 μF)	●	●	—
3	Valve	Rc1	●	●	—
		Rc1/2	●	●	—
4	Valve	Rc1/2	●	●	—
5	Flow meter	Rc1	●	●	Prepare a flow meter with an appropriate flow range.
		Rc1/2	●	●	Prepare a flow meter with an appropriate flow range.
6	Flow meter	Rc1/2	●	●	Prepare a flow meter with an appropriate flow range.
7	Pressure gauge	0 to 1.0 MPa	●	●	—

No.	Description	Size	090	050	Note
8	Y-strainer	Rc1/2 #40	●	●	Install either the strainer or filter. If foreign matter with a size of 20 μm or more are likely to enter, select the particle filter, and then prepare it.
	Filter	Rc1/2 20 μm	●	●	
9	Y-strainer	Rc3/8 #40	●	●	Install either the strainer or filter. If foreign matter with a size of 20 μm or more are likely to enter, select the particle filter, and then prepare it.
	Filter	Rc3/8 20 μm	●	●	
10	Valve	Rc3/8	●	●	—
11	Valve (Part of thermo-chiller)	Rc1/4	●	●	—

Cable Specifications

Power Supply Cable and Earth Leakage Breaker (Recommended)

Model	Power supply voltage specifications	Terminal block screw diameter	Recommended crimped terminal	Cable specifications	Earth leakage breaker	
					Breaker size [A]	Sensitivity current [mA]
HRLE050-□-20	Single-phase 200 to 230 VAC (50/60 Hz)	M5	R5.5-5	3 cores x 5.5 mm ² (3 cores x AWG10) Including grounding cable	30	30
HRLE090-□-20	3-phase 200 VAC (50 Hz) 3-phase 200 to 230 VAC (60 Hz)	M5	R5.5-5	4 cores x 5.5 mm ² (4 cores x AWG10) Including grounding cable	30	
HRLE090-□-40	3-phase 380 to 415 VAC (50/60 Hz) 3-phase 460 to 480 VAC (60 Hz)	M8	R5.5-8	4 cores x 5.5 mm ² (4 cores x AWG10) Including grounding cable	20	

* An example of the cable specifications is when two kinds of vinyl insulated wires with a continuous allowable operating temperature of 70°C at 600 V, are used at an ambient temperature of 30°C. Select the proper size of cable according to an actual condition.

Communication Cable Specifications

Terminal specifications		Cable specifications
Terminal block screw diameter	Recommended crimped terminal	
M4	Y-shape crimped terminal 0.3Y-4N	0.3 mm ² (AWG22) Shielded cable

Function of Each Part

Description	Function
Power supply switch	Power ON/OFF of the product
Operation display panel	Runs and stops the product and performs settings such as for the circulating fluid temperature. For details, refer to the "Operation Display Panel" on page 369.
Fluid level indicator	Indicates the circulating fluid level of the tank. Confirm the level is between "H" and "L."
Product label	Shows the product information such as model number and serial number
Circulating fluid outlet	The circulating fluid is discharged from the outlet port.
Circulating fluid return port	The circulating fluid returns to the return port.
Drain port	This drain port is for draining the circulating fluid in the tank and pump.
Dustproof filter	Inserted to prevent dust or contamination from getting directly on the air-cooled condensers. Clean the filter periodically.
Power cable entry	Insert the power cable into the power cable entry and connect it to the breaker.
Communication cable entry	Insert the communication cable into the communication cable entry and connect it to the communication terminal.
Communication terminal	
Facility water inlet (For water-cooled refrigeration)	Supply facility water to inlet port.
Facility water outlet (For water-cooled refrigeration)	Facility water out from outlet port and return to customer's facility water system.

Operation Display Panel

The basic operation of this unit is controlled through the operation panel on the front of the product.

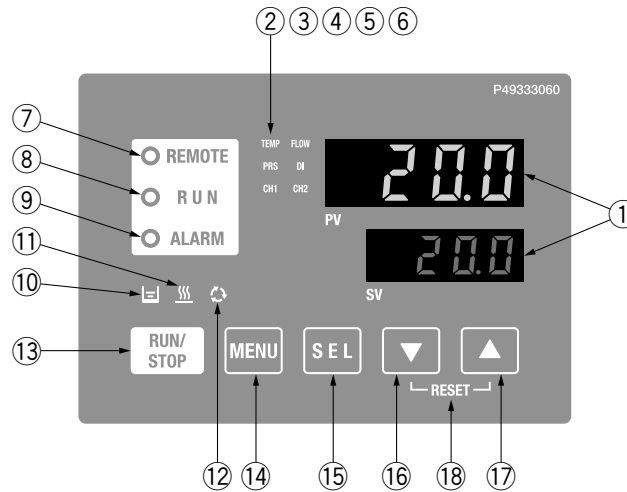

No.	Item	Function	
①	Digital display (7 segments, 4 digits)	PV (Upper line)	Displays the circulating fluid current discharge temperature and pressure and alarm codes and other menu items (codes)
		SV (Lower line)	Displays the circulating fluid discharge temperature and the set values of other menus
②	[TEMP] lamp	Turns ON when the temperature is indicated by ①. The indicated value is in (°C).	
③	[PRS] lamp	Turns ON when the pressure is indicated by ①. The indicated value is in (MPa).	
④	[FLOW] lamp	Not used in this product	
⑤	[DI] lamp	Turns ON when electric conductivity is indicated by ①. The indicated value is in (μS/cm).	
⑥	[CH1/CH2] lamp	Turns ON the CH that is digitally displayed	
⑦	[REMOTE] lamp	Enables remote operation (start and stop) by communication. Turns ON when operation mode is set to DIO or SERIAL	
⑧	[RUN] lamp	Turns ON when the product is started and in operation. Turns OFF when the product is stopped. Blinks during stand-by for stop or during anti-freezing operation	
⑨	[ALARM] lamp	Blinks with an alarm sound if an alarm should occur	
⑩	[L] lamp	Lights up when the surface of the fluid level indicator falls below the L level	
⑪	[W] lamp	Turns ON when the anti-freezing function is enabled. The [RUN] lamp ⑧ blinks during anti-freezing operation.	
⑫	[R] lamp	Not used in this product	
⑬	[RUN/STOP] key	Makes the product start or stop	
⑭	[MENU] key	Shifts the main menu (display screen of circulating fluid discharge temperature and pressure) and other menus (for monitoring and entry of set values)	
⑮	[SEL] key	Changes the item in menu and enters the set value	
⑯	[▼] key	Decreases the set value	
⑰	[▲] key	Increases the set value	
⑱	[RESET] key	Press the [▼] and [▲] keys simultaneously. The alarm sound is stopped and the [ALARM] lamp is reset.	

Alarm

Alarm code	Explanation
AL01	Low level in tank
AL02	CH1 High circulating fluid temp.
AL05	High circulating fluid return temp.
AL06	High circulating fluid discharge pressure
AL08	Circulating fluid discharge pressure rise
AL09	Circulating fluid discharge pressure drop
AL11	Low compressor suction temp.
AL13	Abnormal high-side refrigerant pressure rise
AL15	Refrigerant leakage
AL16	Abnormal low-side refrigerant pressure rise
AL17	Abnormal low-side refrigerant pressure drop
AL18	Compressor running failure
AL19	Communication error
AL22	CH1 Circulating fluid discharge temp. sensor failure
AL23	Circulating fluid return temp. sensor failure
AL24	Compressor suction temp. sensor failure

Alarm code	Explanation
AL25	Circulating fluid discharge pressure sensor failure
AL26	Refrigerant circuit high pressure sensor failure
AL27	Refrigerant circuit low pressure sensor failure
AL31	Contact input 1 signal detection
AL32	Contact input 2 signal detection
AL34	Electric conductivity rise*3
AL35	Electric conductivity decrease*3
AL36	Electric conductivity sensor failure*3
AL37	Compressor discharge temp. sensor failure
AL38	Compressor discharge temp. rise
AL43	Fan failure*4
AL46	Compressor inverter error*1
AL47	Pump running failure
AL48	Pump inverter error*2
AL50	CH2 Circulating fluid temp. is too high
AL51	CH2 Circulating fluid discharge temp. sensor failure

Alarm code	Explanation
AL52	Memory error 1
AL53	Memory error 2
AL56	Abnormal missing-phase/anti-phase
AL57	Compressor inverter communication error*1
AL58	Pump inverter parameter error*2
AL59	Pump inverter communication error*2
AL62	Internal communication error
AL63	Abnormal high-side refrigerant pressure rise
AL64	Power supply failure
AL65	Refrigerant high pressure switch operated
AL66	Compressor inverter parameter error*1

*1 Option C only

*2 Option P only

*3 Occurs only when the electric conductivity control function is enabled

*4 Not generated for the water-cooled type

* For details, read the Operation Manual.

Communication Functions

Contact Input/Output

Item	Specifications	
Connector type	M4 terminal block	
Input signal	Insulation method	Photo coupler
	Rated input voltage	24 VDC
	Operating voltage range	21.6 to 26.4 VDC
	Rated input current	5 mA TYP
	Input impedance	4.7 kΩ
Contact output signal	Rated load voltage	48 VAC or less/30 VDC or less
	Max. load current	500 mA AC/DC (Resistance load)
	Min. load current	5 VDC 10 mA
Output voltage	24 VDC ±10% 200 mA MAX (No inductive load)	
Circuit diagram		

*1 The pin numbers and output signals can be set by the customer. For details, refer to the Operation Manual for communication.

*2 When using with optional accessories, depending on the accessory, the allowable current of 24 VDC devices will be reduced. Refer to the Operation Manual of the optional accessories for details.

Serial Communication

The serial communication (RS-485) enables the following items to be written and read out.

For details, refer to the Operation Manual for communication.

Writing

Run/Stop
Circulating fluid temperature setting (SV)

Readout

Circulating fluid present temperature
Circulating fluid discharge pressure
Status information
Alarm occurrence information

Item	Specifications
Connector type	M4 terminal block
Protocol	Modicon Modbus compliant/Simple communication protocol
Standards	EIA standard RS-485
Circuit diagram	

* The terminal resistance of RS-485 (120 Ω) can be switched by the operation display panel. For details, refer to the Operation Manual for communication. Do not connect other than in the way shown above, as it can result in failure.

Please download the Operation Manual via our website: <https://www.smcworld.com>

HRLE Series Options

C Option symbol

With Inverter for Compressor

HRLE090-□-□-□-**C**

● With inverter for compressor

The inverter for compressor increases the cooling capacity of the 50 Hz area to that of the 60 Hz area. (Refer to the 60 Hz graph under “Cooling Capacity” on page 361.)

* No change in external dimensions

M Option symbol

Deionized Water (Pure Water) Piping

HRLE □-□-□-□-**M**

● Deionized water (Pure water) piping

The contact materials of the circulating fluid circuit are made from non-copper materials.

Applicable model	HRLE050-□-□-□-□-M/HRLE090-□-□-□-□-M
Contact materials of circulating fluid	Stainless steel (including heat exchanger brazing), SiC, Carbon, PA, PP, PE, POM, FKM, EPDM, PVC, PTFE

* No change in external dimensions

P Option symbol

With Inverter for Pump

HRLE090-□-□-□-□-**P**

● With inverter for pump

The inverter for pump increases the pump capacity of the 50 Hz area to that of the 60 Hz area.

Pressure setting is also available, allowing for auto control to any pressure without the need for valve position adjustments.

* No change in external dimensions

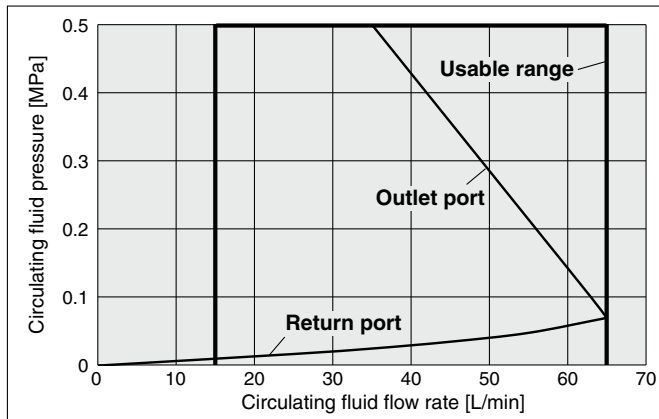

* The pump capacity is the capacity of CH1 when 2 L/min are applied to CH2.

HRLE Series

Optional Accessories

① Piping Conversion Fitting

This is a fitting to change the port from Rc to G or NPT.

Part no.	Description	Applicable model	Circulating fluid inlet/outlet		Facility water inlet/outlet * For the water-cooled type	Drain port
			CH1	CH2		
HRL-EP007	G thread conversion fitting set	HRLE050-A-□	G1/2	G1/2	—	G1/4
HRL-EP008	NPT thread conversion fitting set		NPT1/2	NPT1/2		NPT1/4
HRL-EP009	G thread conversion fitting set	HRLE050-W-□	G1/2	G1/2	G1/2	G1/4
HRL-EP010	NPT thread conversion fitting set		NPT1/2	NPT1/2	NPT1/2	NPT1/4
HRL-EP003	G thread conversion fitting set	HRLE090-A-□	G1	G1/2	—	G1/4
HRL-EP004	NPT thread conversion fitting set		NPT1	NPT1/2		NPT1/4
HRL-EP005	G thread conversion fitting set	HRLE090-W-□	G1	G1/2	G1/2	G1/4
HRL-EP006	NPT thread conversion fitting set		NPT1	NPT1/2	NPT1/2	NPT1/4

When the fitting is required in conjunction with the automatic fluid fill set (accessory sold separately), purchase the following.

Part no.	Description	Applicable model	Circulating fluid inlet/outlet		Facility water inlet/outlet * For the water-cooled type	Drain port	Automatic fluid fill port	Overflow port
			CH1	CH2				
HRL-EP015	G thread conversion fitting set	HRLE050-A-□ +HRL-JK001	G1/2	G1/2	—	G1/4	G3/8	G3/4
HRL-EP016	NPT thread conversion fitting set		NPT1/2	NPT1/2		NPT1/4	NPT3/8	NPT3/4
HRL-EP017	G thread conversion fitting set	HRLE050-W-□ +HRL-JK001	G1/2	G1/2	G1/2	G1/4	G3/8	G3/4
HRL-EP018	NPT thread conversion fitting set		NPT1/2	NPT1/2	NPT1/2	NPT1/4	NPT3/8	NPT3/4
HRL-EP011	G thread conversion fitting set	HRLE090-A-□ +HRL-JK001	G1	G1/2	—	G1/4	G3/8	G3/4
HRL-EP012	NPT thread conversion fitting set		NPT1	NPT1/2		NPT1/4	NPT3/8	NPT3/4
HRL-EP013	G thread conversion fitting set	HRLE090-W-□ +HRL-JK001	G1	G1/2	G1/2	G1/4	G3/8	G3/4
HRL-EP014	NPT thread conversion fitting set		NPT1	NPT1/2	NPT1/2	NPT1/4	NPT3/8	NPT3/4

HRLE Series

② Bypass Piping Set

When the circulating fluid goes below the min. operating flow rate (as shown below), cooling capacity will be reduced and the temperature stability will be badly affected. Use the bypass piping set to ensure a circulating fluid flow rate of the min. operating flow rate or more.

Part no.	Applicable model	Min. operating flow rate [L/min]
HRL-BP002	HRLE050-□-□	CH1: 15/15 (50/60 Hz)
		CH2: 1/1 (50/60 Hz)
HRL-BP001	HRLE090-□-□	CH1: 25/35 (50/60 Hz)
		CH2: 1/1 (50/60 Hz)

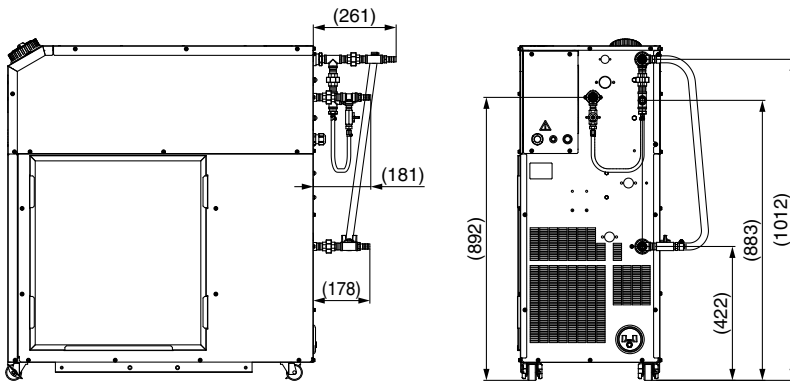
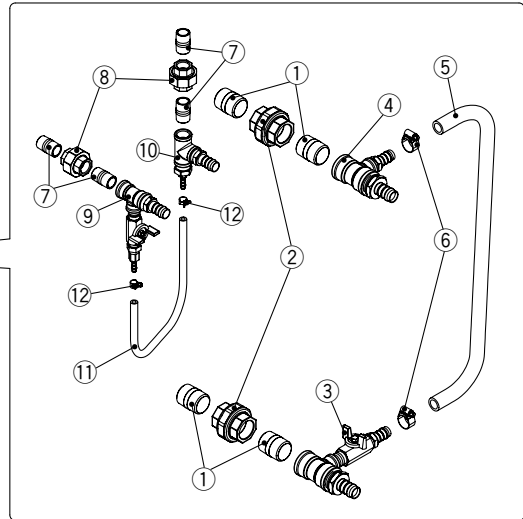
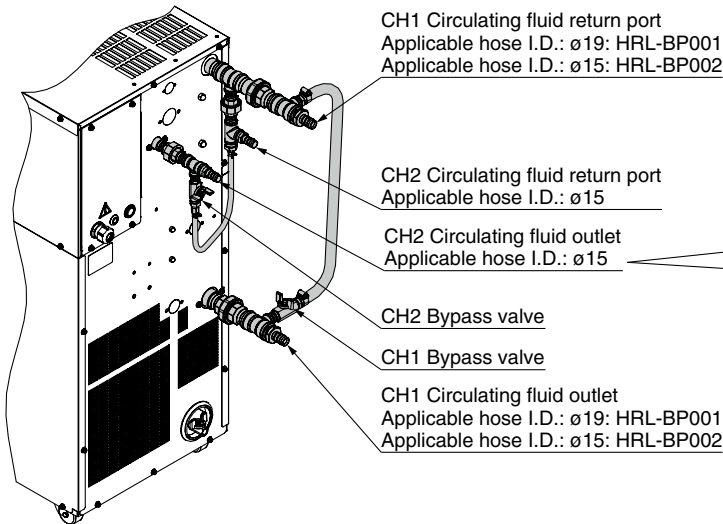

Mounting dimensions: HRLE050

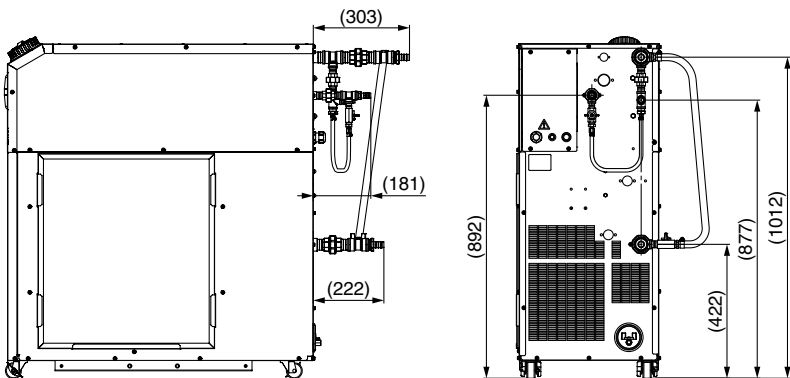

Mounting dimensions: HRLE090

Parts List

No.	Description	Fluid contact material	Qty.
①	Nipple (Size: 1 inch...HRL-BP001) : 1/2 inch...HRL-BP002)	Stainless steel	4
②	Union (Size: 1 inch...HRL-BP001) : 1/2 inch...HRL-BP002)	Stainless steel	2
③	CH1 Outlet piping assembly (Applicable hose I.D.: ø19...HRL-BP001) : ø15...HRL-BP002)	Stainless steel, PA	1
④	CH1 Return piping assembly (Applicable hose I.D.: ø19...HRL-BP001) : ø15...HRL-BP002)	Stainless steel, PA	1
⑤	Hose	PVC	1
⑥	Hose band	—	2
⑦	Nipple (Size: 1 inch...HRL-BP001) : 1/2 inch...HRL-BP002)	Stainless steel	4
⑧	Union (Size: 1 inch...HRL-BP001) : 1/2 inch...HRL-BP002)	Stainless steel	2
⑨	CH2 Outlet piping assembly (Applicable hose I.D.: ø19...HRL-BP001) : ø15...HRL-BP002)	Stainless steel, PA	1
⑩	CH2 Return piping assembly (Applicable hose I.D.: ø19...HRL-BP001) : ø15...HRL-BP002)	Stainless steel, PA	1
⑪	Hose	PVC	1
⑫	Hose clamp	—	2
⑬	Sealant tape	PTFE	1

③ Electric Conductivity Control Set

This set can be used to display and control the electric conductivity of the circulating fluid. Refer to the Operation Manual for details.

Part no.	Applicable model
HRL-DI002	HRLE050 -□-□
HRL-DI001	HRLE090 -□-□

Measurement range of electric conductivity	2.0 to 48.0 $\mu\text{S/cm}$
Set range of target electric conductivity	0.5 to 45.0 $\mu\text{S/cm}$
Set range of electric conductivity hysteresis	0.1 to 10.0 $\mu\text{S/cm}$
Operating temperature range (Circulating fluid temperature)	5 to 60°C
Power consumption	400 mA or less

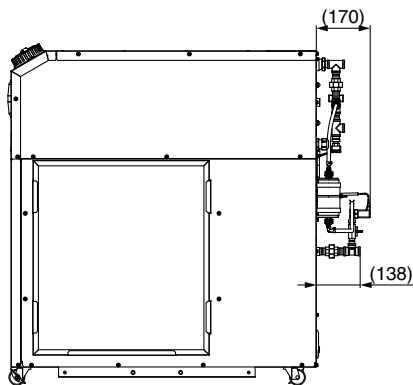
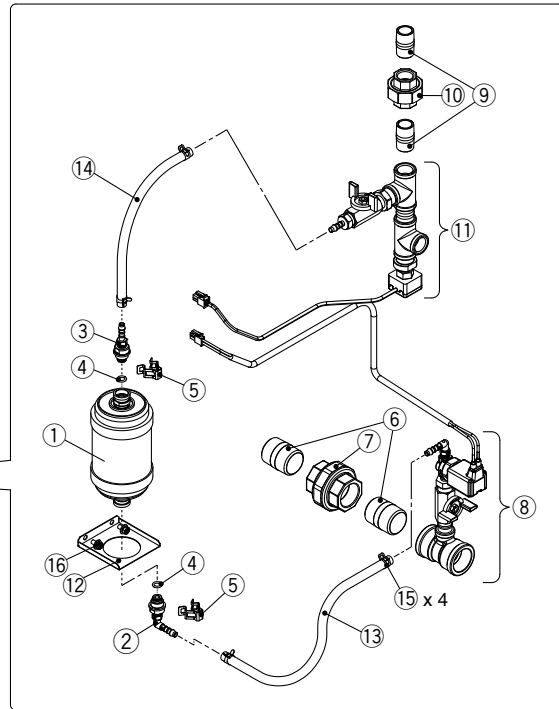
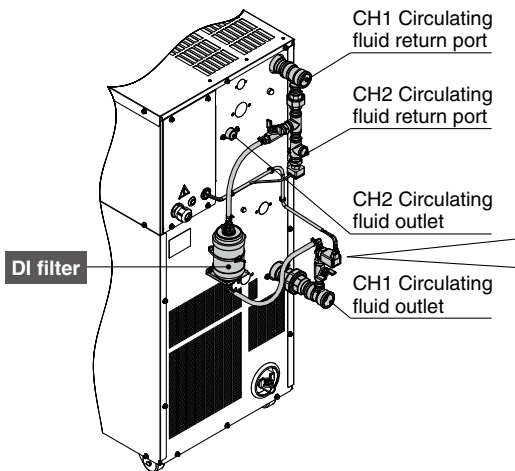

Mounting dimensions: HRLE050

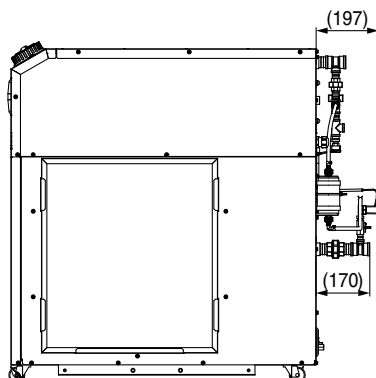

Mounting dimensions: HRLE090

Parts List

No.	Description	Fluid contact material	Qty.
①	DI filter cartridge (Part no.: HRR-DF001)*1	PP, PE	1
②	DI filter inlet fitting assembly	Stainless steel, PA	1
③	DI filter outlet fitting assembly	Stainless steel, PA	1
④	O-ring	EPDM	2
⑤	Clip	—	2
⑥	Nipple (Size: 1 inch...HRL-DI001) : 1/2 inch...HRL-DI002)	Stainless steel	2
⑦	Union (Size: 1 inch...HRL-DI001) : 1/2 inch...HRL-DI002)	Stainless steel	1
⑧	DI control piping assembly	Stainless steel	1
⑨	Nipple (Size: 1/2 inch)	Stainless steel	2
⑩	Union (Size: 1/2 inch)	Stainless steel	1
⑪	DI sensor piping assembly	Stainless steel	1
⑫	Mounting bracket	—	1
⑬	DI filter inlet hose	PVC	1
⑭	DI filter outlet hose	PVC	1
⑮	Hose clamp	—	4
⑯	Mounting screw (Size: M5)	—	2
⑰	Cable tie holder	—	5
⑱	Binding band	—	4
⑲	Reusable band	—	1
⑳	Sealant tape	PTFE	1
㉑	DI control solenoid valve extension cable	—	1

*1 The product should be replaced when it can no longer preserve the electrical conductivity set value.

HRLE Series

④ Particle Filter Set

This set can be used to remove foreign matter from the circulating fluid. If foreign matter such as scales in the piping enter the circulating fluid, this may cause the pump to malfunction. Therefore, it is strongly recommended to install the particle filter set. This set cannot be directly connected to the thermo-chiller. Install it in the customer's piping system. For details, refer to the Operation Manual.

■ Particle filter set (For HRLE090, CH1)

HRL-PF001

Fluid	Tap water
Max. operating pressure	0.65 MPa
Operating temperature range	5 to 35°C
Nominal filtration accuracy	5 μm
Installation environment	Indoors

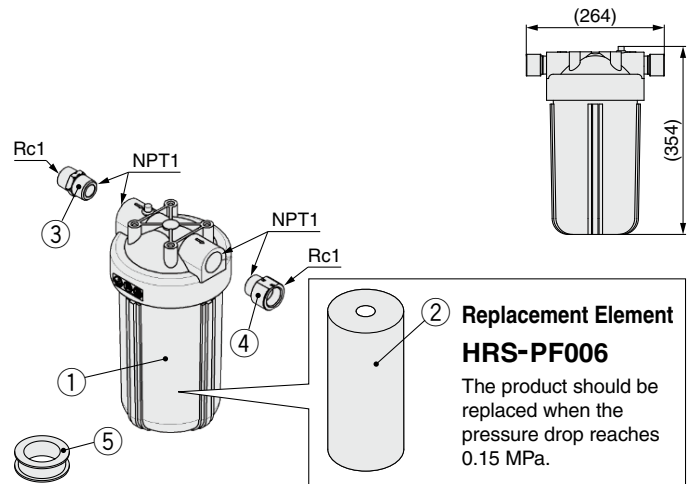

* If a handle is required, please order it separately.
Handle: HRS-S0600

Parts List

No.	Description	Material	Qty.	Note
①	Body	PC, PP	1	—
②	Element	PP	1	—
③	Conversion nipple	Stainless steel	2	Conversion from NPT to Rc
④	Conversion fitting	Stainless steel	2	Conversion from NPT to Rc
⑤	Sealant tape	PTFE	1	—

■ Particle filter set (For HRLE050, CH1/CH2) (For HRLE090, CH2)

This set can be used to remove foreign matter from the circulating fluid.

HRL-PF002

Fluid	Tap water
Max. operating pressure	0.50 MPa
Operating temperature range	5 to 35°C
Nominal filtration accuracy	5 μm
Installation environment	Indoors

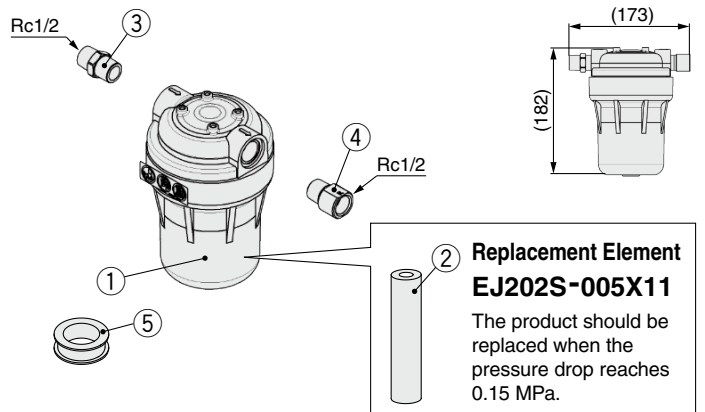

* If a handle is required, please order it separately.
Handle: HRR-S0079

Parts List

No.	Description	Material	Qty.	Note
①	Body	PP	1	—
②	Element	PP, PE	1	—
③	Conversion nipple	Stainless steel	2	—
④	Conversion fitting	Stainless steel	2	—
⑤	Sealant tape	PTFE	1	—

⑤ Filter for Circulating Fluid Fill Port

Prevents foreign matter from entering the tank when supplying the circulating fluid. Can be used just by fitting into the circulating fluid fill port.

■ Filter for circulating fluid fill port HRS-PF007

Material	Stainless steel 304, Stainless steel 316
Mesh size	200

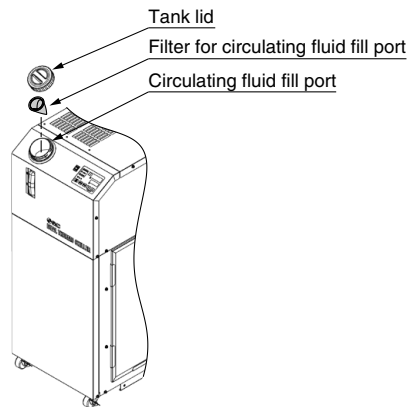

⑥ Automatic Fluid Fill Set

By installing this at the automatic fluid fill port, the circulating fluid can be automatically supplied to the product while the circulating fluid is decreasing.

Part no.	Applicable model
HRL-JK001	HRLE050 -□-□ HRLE090 -□-□

Fluid fill pressure [MPa]	0.2 to 0.5
Feed water temperature [°C]	15 to 25
Fluid fill method	Ball tap

Parts List

No.	Description	Material	Qty.	Note
①	Overflow port assembly		1	
②	Automatic fluid fill assembly		1	
③	Automatic fluid fill tank assembly	PE	1	
④	M4 screw	—	2	For securing automatic fluid fill assembly
⑤	M6 screw	—	2	For securing overflow port assembly
⑥	Hose clamp	—	1	For securing automatic fluid fill assembly hose
⑦	Hose clamp	—	1	For securing overflow port assembly hose
⑧	Automatic fluid fill label	—	1	

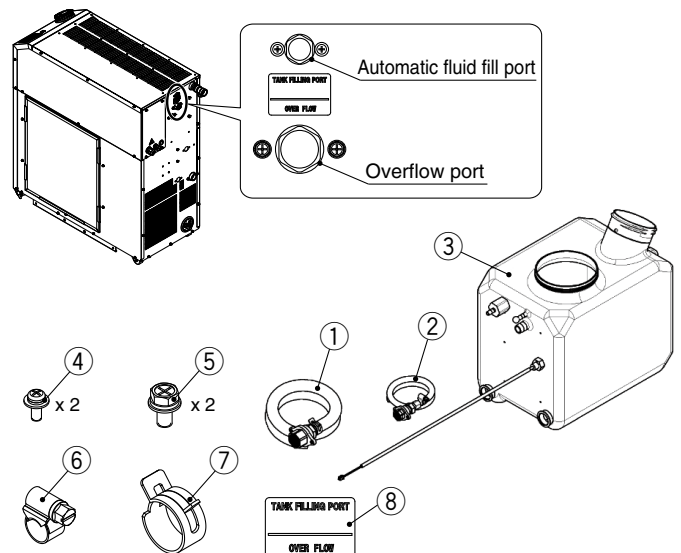

⑦ Ball Valve Set (With Pressure Gauge)

This is a set of fittings including a ball valve and a pressure gauge to be used when adjusting the circulating fluid discharge pressure and flow rate at the chiller.

Part no.	Applicable model
HRL-BB002	HRLE050 -□-□
HRL-BB001	HRLE090 -□-□

Parts List

No.	Description	Material	Applicable model	Size	Qty.	Note
①	Nipple	Stainless steel	HRLE090	R1	2	For CH1
			HRLE050	R1/2		
②	Ball valve	Stainless steel	HRLE090	Rc1	1	For CH1
			HRLE050	Rc1/2		
③	Different diameter tee	Stainless steel	HRLE090	Rc1 x Rc3/8	1	For CH1
			HRLE050	Rc1/2 x Rc3/8		
④	Hexagon bushing	Stainless steel	HRLE090/050	Rc3/8 x Rc1/4	2	For CH1/CH2
⑤	Pressure gauge	—	HRLE090/050	R1/4	2	For CH1/CH2
⑥	Nipple	Stainless steel	HRLE090/050	R1/2	2	For CH2
⑦	Ball valve	Stainless steel	HRLE090/050	Rc1/2	1	For CH2
⑧	Different diameter tee	Stainless steel	HRLE090/050	Rc1/2 x Rc3/8	1	For CH2
⑨	Sealant tape	PTFE	HRLE090/050	—	1	

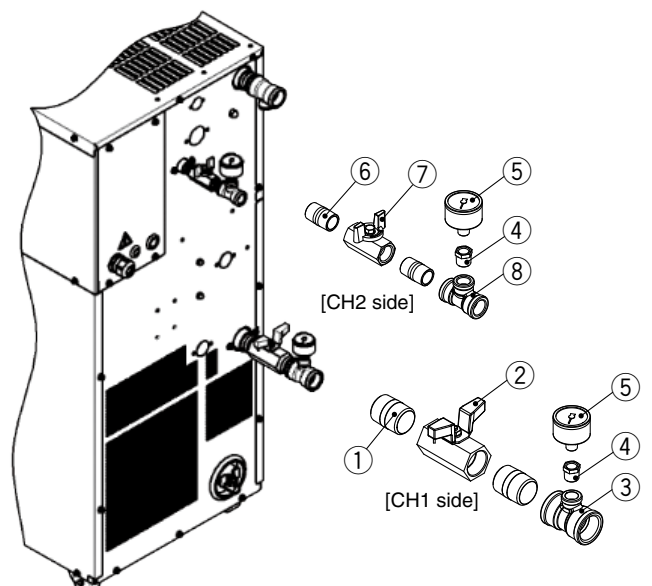

Cooling Capacity Calculation

Required Cooling Capacity Calculation

Example 1: When the heat generation amount in the customer equipment is known.

The heat generation amount can be determined based on the power consumption or output of the heat generating area — i.e. the area requiring cooling — within the customer equipment.*1

- ① Derive the heat generation amount from the power consumption.

Power consumption P: 7 [kW]

$$Q = P = 7 \text{ [kW]}$$

Cooling capacity = Considering a safety factor of 20%, 7 [kW] x 1.2 = **8.4 [kW]**

- ③ Derive the heat generation amount from the output. Output (shaft power, etc.) W: 5.1 [kW]

$$Q = P = \frac{W}{\text{Efficiency}}$$

In this example, using an efficiency of 0.7:

$$= \frac{5.1}{0.7} = 7.3 \text{ [kW]}$$

Cooling capacity = Considering a safety factor of 20%, 7.3 [kW] x 1.2 = **8.8 [kW]**

- ② Derive the heat generation amount from the power supply output.

Power supply output VI: 8.8 [kVA]

$$Q = P = V \times I \times \text{Power factor}$$

In this example, using a power factor of 0.85:

$$= 8.8 \text{ [kVA]} \times 0.85 = 7.5 \text{ [kW]}$$

Cooling capacity = Considering a safety factor of 20%, 7.5 [kW] x 1.2 = **9.0 [kW]**

- ④ Calculate based on the laser output.

Laser output power 3 [kW], conversion efficiency 30%

The oscillator's power consumption is, 3 [kW] ÷ 0.3 = 10 [kW]

The cooling capacity required for the oscillator is,

$$10 \text{ [kW]} - 3 \text{ [kW]} = 7 \text{ [kW]}$$

Considering a safety factor of 20%, 7 [kW] x 1.2 = **8.4 [kW]**

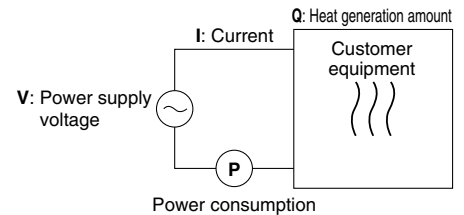

*1 The examples above calculate the heat generation amount based on the power consumption. The actual heat generation amount may differ due to the structure of the customer equipment. Be sure to check it carefully.

Example 2: When the heat generation amount in the customer equipment is not known.

Obtain the temperature difference between inlet and outlet by circulating the circulating fluid inside the customer equipment.

Heat generation amount by customer equipment Q	: Unknown [W] ((J/s))
Circulating fluid	: Tap water*1
Circulating fluid mass flow rate qm	: (= ρ x qv ÷ 60) [kg/s]
Circulating fluid density ρ	: 1 [kg/L]
Circulating fluid (volume) flow rate qv	: 35 [L/min]
Circulating fluid specific heat C	: 4.186 x 10 ³ [J/(kg·K)]
Circulating fluid outlet temperature T1	: 293 [K] (20 [°C])
Circulating fluid return temperature T2	: 296 [K] (23 [°C])
Circulating fluid temperature difference ΔT	: 3 [K] (= T ₂ - T ₁)
Conversion factor: minutes to seconds (SI units)	: 60 [s/min]

*1 Refer to page 378 for the typical physical property value of tap water or other circulating fluids.

$$Q = qm \times C \times (T_2 - T_1)$$

$$= \frac{\rho \times qv \times C \times \Delta T}{60} = \frac{1 \times 35 \times 4.186 \times 10^3 \times 3.0}{60}$$

$$= 7325 \text{ [J/s]} \approx 7325 \text{ [W]} = 7.3 \text{ [kW]}$$

Cooling capacity = Considering a safety factor of 20%,

$$7.3 \text{ [kW]} \times 1.2 = \mathbf{8.8 \text{ [kW]}}$$

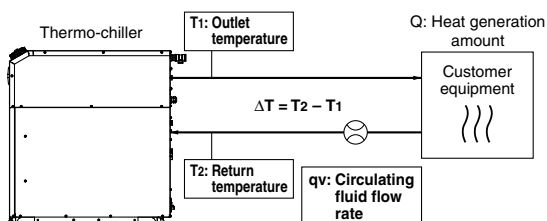

HRLE090-A

Example of conventional units (Reference)

Heat generation amount by customer equipment Q	: Unknown [cal/h] → [W]
Circulating fluid	: Tap water*1
Circulating fluid weight flow rate qm	: (= ρ x qv x 60) [kgf/h]
Circulating fluid weight volume ratio γ	: 1 [kgf/L]
Circulating fluid (volume) flow rate qv	: 35 [L/min]
Circulating fluid specific heat C	: 1.0 x 10 ³ [cal/(kgf·°C)]
Circulating fluid outlet temperature T1	: 20 [°C]
Circulating fluid return temperature T2	: 23 [°C]
Circulating fluid temperature difference ΔT	: 3 [°C] (= T ₂ - T ₁)
Conversion factor: hours to minutes	: 60 [min/h]
Conversion factor: kcal/h to kW	: 860 [(cal/h)/W]

$$Q = \frac{qm \times C \times (T_2 - T_1)}{860}$$

$$= \frac{\gamma \times qv \times 60 \times C \times \Delta T}{860}$$

$$= \frac{1 \times 35 \times 60 \times 1.0 \times 10^3 \times 3.0}{860}$$

$$\approx 7325 \text{ [W]} = 7.3 \text{ [kW]}$$

Cooling capacity = Considering a safety factor of 20%,

$$7.3 \text{ [kW]} \times 1.2 = \mathbf{8.8 \text{ [kW]}}$$

Required Cooling Capacity Calculation

Example 3: When there is no heat generation, and when cooling the object below a certain temperature and period of time.

Heat quantity by cooled substance (per unit time) **Q** : Unknown [W] ([J/s])
 Cooled substance : Water
 Cooled substance mass **m** : (= $\rho \times V$) [kg]
 Cooled substance density ρ : 1 [kg/L]
 Cooled substance total volume **V** : 150 [L]
 Cooled substance specific heat **C** : 4.186×10^3 [J/(kg·K)]
 Cooled substance temperature when cooling begins **T₀** : 303 [K] (30 [°C])
 Cooled substance temperature after t hour **T_t** : 293 [K] (20 [°C])
 Cooling temperature difference ΔT : 10 [K] (= $T_0 - T_t$)
 Cooling time Δt : 900 [s] (= 15 [min])

* Refer to the following for the typical physical property values by circulating fluid.

$$Q = \frac{m \times C \times (T_0 - T_t)}{\Delta t} = \frac{\rho \times V \times C \times \Delta T}{\Delta t}$$

$$= \frac{1 \times 150 \times 4.186 \times 10^3 \times 10}{900} = 6977 \text{ [J/s]} \approx 7.0 \text{ [kW]}$$

Cooling capacity = Considering a safety factor of 20%,
 $7.0 \text{ [kW]} \times 1.2 = \mathbf{8.4 \text{ [kW]}}$

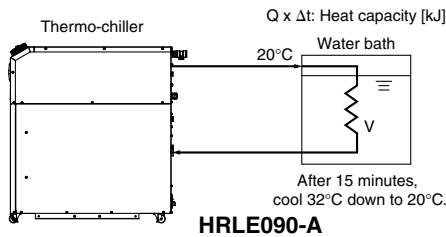

Example of conventional units (Reference)

Heat quantity by cooled substance (per unit time) **Q** : Unknown [cal/h] → [W]
 Cooled substance : Water
 Cooled substance weight **m** : (= $\rho \times V$) [kgf]
 Cooled substance weight volume ratio γ : 1 [kgf/L]
 Cooled substance total volume **V** : 150 [L]
 Cooled substance specific heat **C** : 1.0×10^3 [cal/(kgf·°C)]
 Cooled substance temperature when cooling begins **T₀** : 30 [°C]
 Cooled substance temperature after t hour **T_t** : 20 [°C]
 Cooling temperature difference ΔT : 10 [°C] (= $T_0 - T_t$)
 Cooling time Δt : 15 [min]
 Conversion factor: hours to minutes : 60 [min/h]
 Conversion factor: kcal/h to kW : 860 [(cal/h)/W]

$$Q = \frac{m \times C \times (T_0 - T_t)}{\Delta t \times 860} = \frac{\gamma \times V \times 60 \times C \times \Delta T}{\Delta t \times 860}$$

$$= \frac{1 \times 150 \times 60 \times 1.0 \times 10^3 \times 10}{15 \times 860}$$

$$\approx 6977 \text{ [W]} = 7.0 \text{ [kW]}$$

Cooling capacity = Considering a safety factor of 20%,
 $7.0 \text{ [kW]} \times 1.2 = \mathbf{8.4 \text{ [kW]}}$

* This is the calculated value by changing the fluid temperature only. Thus, it varies substantially depending on the water bath or piping shape.

Precautions on Cooling Capacity Calculation

1. Heating capacity

When the circulating fluid temperature is set above room temperature, it needs to be heated by the thermo-chiller. The heating capacity depends on the circulating fluid temperature. Consider the radiation rate and heat capacity of the customer equipment and check beforehand if the required heating capacity is provided.

2. Pump capacity

<Circulating fluid flow rate>

Circulating fluid flow rate varies depending on the circulating fluid discharge pressure. Consider the installation height difference between the thermo-chiller and the customer equipment, and the piping resistance such as circulating fluid pipings, or piping size, or piping curves in the machine. Check beforehand if the required flow is achieved, using the pump capacity curves.

<Circulating fluid discharge pressure>

Circulating fluid discharge pressure has the possibility to increase up to the max. pressure in the pump capacity curves. Check beforehand if the circulating fluid pipings or circulating fluid circuit of the customer equipment are fully durable against this pressure.

Circulating Fluid Typical Physical Property Values

1. This catalog uses the following values for density and specific heat in calculating the required cooling capacity.

Density ρ : 1 [kg/L] (or, using conventional units, weight volume ratio $\gamma = 1$ [kgf/L])

Specific heat **C**: 4.19×10^3 [J/(kg·K)] (or, using conventional units, 1×10^3 [cal/(kgf·°C)])

2. Values for density and specific heat change slightly according to temperature shown below. Use this as a reference.

Water

Physical property value Temperature	Density ρ [kg/L]	Specific heat C [J/(kg·K)]	Conventional units	
			Weight volume ratio γ [kgf/L]	Specific heat C [cal/(kgf·°C)]
5°C	1.00	4.2×10^3	1.00	1×10^3
10°C	1.00	4.19×10^3	1.00	1×10^3
15°C	1.00	4.19×10^3	1.00	1×10^3
20°C	1.00	4.18×10^3	1.00	1×10^3
25°C	1.00	4.18×10^3	1.00	1×10^3
30°C	1.00	4.18×10^3	1.00	1×10^3
35°C	0.99	4.18×10^3	0.99	1×10^3
40°C	0.99	4.18×10^3	0.99	1×10^3

15% Ethylene Glycol Aqueous Solution

Physical property value Temperature	Density ρ [kg/L]	Specific heat C [J/(kg·K)]	Conventional units	
			Weight volume ratio γ [kgf/L]	Specific heat C [cal/(kgf·°C)]
5°C	1.02	3.91×10^3	1.02	0.93×10^3
10°C	1.02	3.91×10^3	1.02	0.93×10^3
15°C	1.02	3.91×10^3	1.02	0.93×10^3
20°C	1.01	3.91×10^3	1.01	0.93×10^3
25°C	1.01	3.91×10^3	1.01	0.93×10^3
30°C	1.01	3.91×10^3	1.01	0.94×10^3
35°C	1.01	3.91×10^3	1.01	0.94×10^3
40°C	1.01	3.92×10^3	1.01	0.94×10^3

* Shown above are reference values. Contact circulating fluid supplier for details.



HRLE Series

Specific Product Precautions 1

Be sure to read this before handling the products. For safety instructions and temperature control equipment precautions, refer to the “Handling Precautions for SMC Products” and the “Operation Manual” on the SMC website: <https://www.smcworld.com>

Design

⚠ Warning

1. This catalog shows the specifications of a single unit.

1. Check the specifications of the single unit (contents of this catalog) and thoroughly consider the adaptability between the customer system and this unit.
2. Although a protection circuit as a single unit is installed, prepare a drain pan, water leakage sensor, discharge air facility, and emergency stop equipment, depending on the customer’s operating conditions. Also, the customer is requested to carry out a safety design for the whole system.

2. When attempting to cool areas that are open to the atmosphere (tanks, pipes), plan your piping system accordingly.

When cooling open-air external tanks, arrange the piping so that there are coil pipes for cooling inside the tanks and to carry back the entire flow volume of circulating fluid that is released.

3. Use non-corrosive materials for circulating fluid contact parts.

The recommended circulating fluid is tap water or deionized (pure) water. Using corrosive materials such as aluminum or iron for fluid contact parts such as piping may cause clogging or leakage in the circulating fluid circuit. Therefore, take sufficient care when selecting fluid contact part materials such as piping.

4. Design the piping so that no foreign matter enters the chiller.

If foreign matter, such as scales in the piping, enters the circulating fluid, this may cause the pump to malfunction. Therefore, it is strongly recommended to install the particle filter.

5. The facility water outlet temperature (water-cooled type) may increase up to around 60°C.

When selecting the facility water pipings, consider the suitability for temperature.

Selection

⚠ Warning

Model selection

When selecting a thermo-chiller model, the amount of heat generation from the customer equipment must be known. Obtain this value, referring to the “Cooling Capacity Calculation” on pages 377 and 378 before selecting a model.

Handling

⚠ Warning

Thoroughly read the Operation Manual.

Read the Operation Manual completely before operation, and keep the manual where it can be referred to as necessary.

Operating Environment / Storage Environment

⚠ Warning

1. Do not use in the following environment as it will lead to a breakdown.

1. In locations where liquid that exceeds the conditions required for the degrees of protection IPX4 may splash on the product
2. In locations where dust, water vapor, salt water, and oil may splash on the product
3. In locations where there are dust and particles
4. In locations where corrosive gases, organic solvents, chemical fluids, or flammable gases are present (This product is not explosion proof.)
5. In locations where the ambient temperature/humidity exceeds the limits as mentioned below or where condensation occurs
During transportation/storage: 0°C to 50°C, 15% to 85%
(But as long as water or circulating fluid are not left inside the pipings)

During operation: 2°C to 45°C, 30% to 70%

6. In locations where condensation may occur
7. In locations which receive direct sunlight or radiated heat
8. In locations where there is a heat source nearby and the ventilation is poor
9. In locations where temperature substantially changes
10. In locations where strong magnetic noise occurs
(In locations where strong electric fields, strong magnetic fields and surge voltage occur)
11. In locations where static electricity occurs, or conditions which make the product discharge static electricity
12. In locations where high frequency occurs
13. In locations where damage is likely to occur due to lightning
14. In locations at an altitude of 3000 m or higher (Except during storage and transportation)

* For altitudes of 1000 m or higher

Because of lower air density, the heat radiation efficiencies of the devices in the product will be lower in the location at an altitude of 1000 m or higher. Therefore, the max. ambient temperature to use and the cooling capacity will lower according to the descriptions in the table below.

Select the thermo-chiller considering the descriptions.

- ① Upper limit of ambient temperature: Use the product in ambient temperature of the described value or lower at each altitude.
- ② Cooling capacity coefficient: The product’s cooling capacity will lower to one that multiplied by the described value at each altitude.

Altitude [m]	① Upper limit of ambient temperature [°C]	② Cooling capacity coefficient
Less than 1000 m	45	1.00
Less than 1500 m	42	0.85
Less than 2000 m	38	0.80
Less than 2500 m	35	0.75
Less than 3000 m	32	0.70

15. In locations where strong impacts or vibrations occur
16. In locations where a massive force strong enough to deform the product is applied or a weight from a heavy object is applied
17. In locations where there is not sufficient space for maintenance
18. Bevelled place
19. Insects or plants may enter the unit.

2. The product is not designed for clean room usage. It generates particles internally.



HRLE Series Specific Product Precautions 2

Be sure to read this before handling the products. For safety instructions and temperature control equipment precautions, refer to the “Handling Precautions for SMC Products” and the “Operation Manual” on the SMC website: <https://www.smcworld.com>

Transportation / Carriage / Movement

Warning

1. This product is heavy. Pay attention to safety and the position of the product when it is transported, carried, and moved.
2. Read the Operation Manual carefully before moving the product after unpacking.

Caution

1. Never put the product down on its side as this may cause a failure.

The product will be delivered in the packaging shown below.

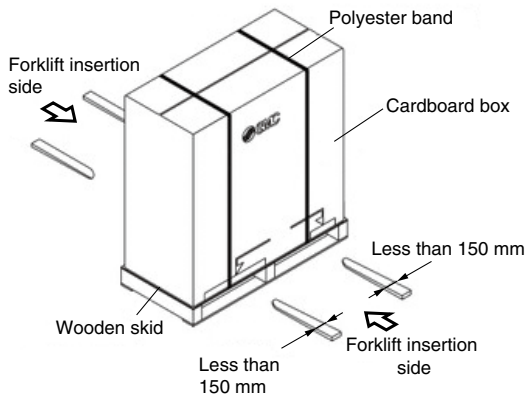

<When packaged>

Model	Weight [kg]	Dimensions [mm]
HRLE050-A-20	150	Height 1320 x Width 580 x Depth 1240
HRLE050-W-20	143	
HRLE090-A-20/40	176	
HRLE090-W-20/40	170	

2. Transporting with forklift

1. A licensed driver should drive the forklift.
2. Insert the fork to the place specified on the label. The fork should reach through to the other side of the product.
3. Be careful not to bump the fork to the cover panel or piping ports.

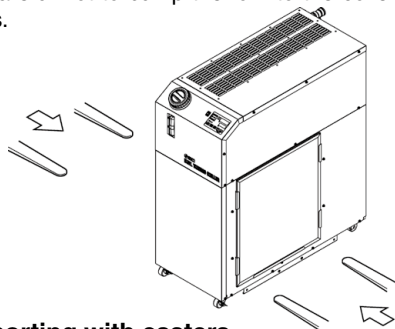

3. Transporting with casters

1. This product is heavy and should be moved by at least two people to avoid falling.
2. Do not grip the piping port on the back side or the handles of the panel.
3. Do not pass over bumps, etc., with the casters.

Caution

If this product is to be transported after delivery, please use the original packaging the product was delivered in. If other packaging is to be used, carefully package the product so as to prevent the product from incurring any damage during transport.

Installation

Warning

1. Do not place heavy objects on top of this product, or step on it.
The external panel can be deformed and danger can result.

Caution

1. Install on a rigid floor which can withstand this product's weight.
2. Refer to the Operation Manual for this product, and secure an installation space that is necessary for the maintenance and ventilation.

<Air-cooled refrigeration>

1. The air-cooled type product exhausts heat using the fan that is mounted to the product. If the product is operated with insufficient ventilation, ambient temperature may exceed 45°C, and this will affect the performance and life of the product. To prevent this ensure that suitable ventilation is available (see below).
2. For installation indoors, ventilation ports and a ventilation fan should be equipped as needed.

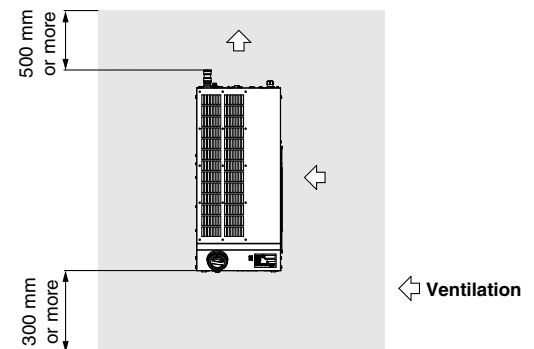
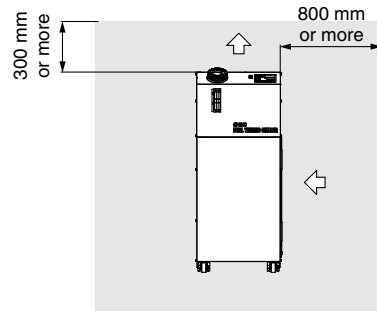

3. If it is impossible to exhaust heat from the installation area indoors, or when the installation area is conditioned, provide a duct for heat exhaustion to the air outlet port of this product for ventilation. Do not mount the inlet of the duct (flange) directly to the air vent of the product, and keep a space larger than the diameter of the duct. Additionally, consider the resistance of the duct when making the air vent port for the duct.

<Heat radiation amount / Required ventilation rate>

Model	Heat radiation amount [kW]	Required ventilation rate [m ³ /min]	
		Differential temp. of 3°C between inside and outside of installation area	Differential temp. of 6°C between inside and outside of installation area
HRLE050-A-20	Approx.10	140	70
HRLE090-A-20/40	Approx.18	305	155



HRLE Series Specific Product Precautions 3

Be sure to read this before handling the products. For safety instructions and temperature control equipment precautions, refer to the “Handling Precautions for SMC Products” and the “Operation Manual” on the SMC website: <https://www.smcworld.com>

Piping

⚠ Caution

1. The circulating fluid and facility water piping should be prepared by the customer with consideration of the operating pressure, temperature, and circulating fluid/facility compatibility.

If the operating performance is not sufficient, the pipings may burst during operation. Also, the use of corrosive materials such as aluminum or iron for fluid contact parts, such as piping, may not only lead to clogging or leakage in the circulating fluid and facility water circuits but also refrigerant leakage and other unexpected problems. Provide protection against corrosion when you use the product.

2. Select the piping port size which can exceed the rated flow. For the rated flow, refer to the pump capacity table.
3. When tightening at the drain port of this product, use a pipe wrench to clamp the connection ports.
4. For the circulating fluid piping connection, install a drain pan and wastewater collection pit just in case the circulating fluid may leak.
5. This product series are constant-temperature fluid circulating machines with built-in tanks. Do not install equipment on your system side such as pumps that forcibly return the circulating fluid to the unit. Also, if you attach an external tank that is open to the air, it may become impossible to circulate the circulating fluid. Proceed with caution.
6. The facility water flow rate is adjusted automatically according to the operating conditions. In addition, the facility water return temperature is 60°C at max.

Circulating Fluid

⚠ Caution

1. Avoid oil or other foreign matter entering the circulating fluid.
2. When water is used as a circulating fluid, SMC recommends the water quality shown in the following table as reference.
 - Including water used for dilution of ethylene glycol aqueous solutions.
 - In most areas, tap water can be used. However, if the tap water in the area is hard, there is a possibility of failure or performance decline due to limescale build-up. To soften the water and avoid problems, consider using water hardness filters.

Tap Water (as a Circulating Fluid) Quality Standards

The Japan Refrigeration and Air Conditioning Industry Association
JRA GL-02-1994 “Cooling water system – Circulation type – Make-up water”

	Item	Unit	Standard value	Influence	
				Corrosion	Scale generation
Standard item	pH (at 25°C)	—	6.0 to 8.0	○	○
	Electric conductivity (25°C)	[μS/cm]	100*1 to 300*1	○	○
	Chloride ion (Cl ⁻)	[mg/L]	50 or less	○	
	Sulfuric acid ion (SO ₄ ²⁻)	[mg/L]	50 or less	○	
	Acid consumption amount (at pH4.8)	[mg/L]	50 or less		○
	Total hardness	[mg/L]	70 or less		○
	Calcium hardness (CaCO ₃)	[mg/L]	50 or less		○
	Ionic state silica (SiO ₂)	[mg/L]	30 or less		○
Reference item	Iron (Fe)	[mg/L]	0.3 or less	○	○
	Copper (Cu)	[mg/L]	0.1 or less	○	
	Sulfide ion (S ₂ ⁻)	[mg/L]	Should not be detected	○	
	Ammonium ion (NH ₄ ⁺)	[mg/L]	0.1 or less	○	
	Residual chlorine (Cl)	[mg/L]	0.3 or less	○	
	Free carbon (CO ₂)	[mg/L]	4.0 or less	○	

*1 In the case of [MΩ·cm], it will be 0.003 to 0.01.

- : Factors that have an effect on corrosion or scale generation
- Even if the water quality standards are met, complete prevention of corrosion is not guaranteed.

3. When deionized (pure) water is used, the electric conductivity should be 0.5 μS/cm or higher (Electric resistivity: 2 MΩ·cm or lower).

Electrical Wiring

⚠ Warning

Grounding should never be connected to a water line, gas line or lightning rod.

⚠ Caution

1. Power supply and communication cables should be prepared by the customer.

2. Provide a stable power supply which is not affected by surge or distortion.

If the voltage increase ratio (dV/dt) at the zero cross should exceed 40 V/200 μsec., it may result in malfunction.

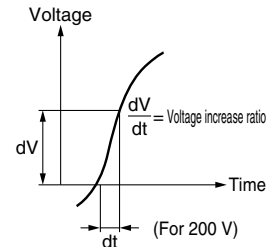

3. This product is installed with a breaker with the following operating characteristics.

For the customer system side (on the upstream side), use a breaker whose operating time is equal to or longer than the breaker of this product. If a breaker with shorter operating time is connected, the customer equipment could be cut off due to the inrush current of the motor of this product.

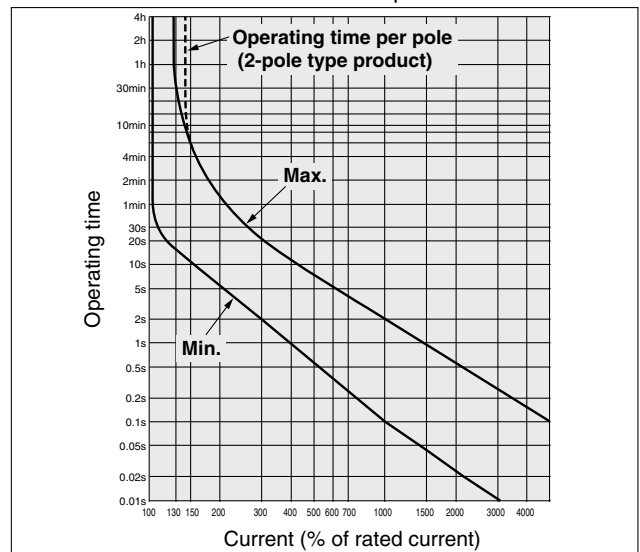

HRLE050

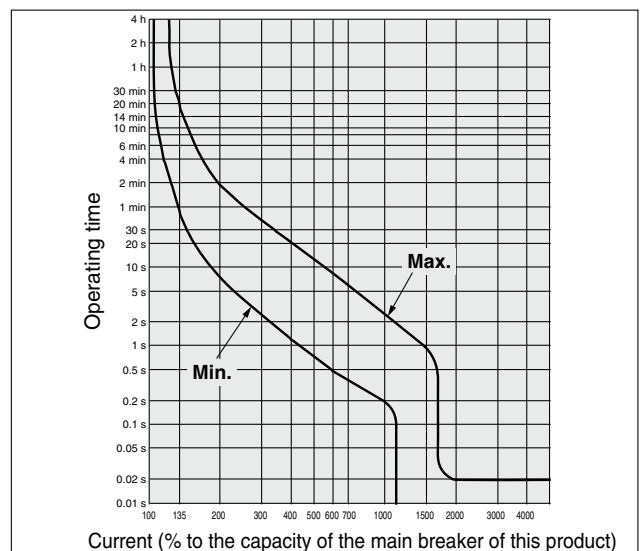

HRLE090



HRLE Series

Specific Product Precautions 4

Be sure to read this before handling the products. For safety instructions and temperature control equipment precautions, refer to the “Handling Precautions for SMC Products” and the “Operation Manual” on the SMC website: <https://www.smcworld.com>

Facility Water Supply

Warning

<Water-cooled refrigeration>

1. The water-cooled refrigeration type thermo-chiller radiates heat to the facility water. Prepare the facility water system that satisfies the heat radiation and the facility water specifications below.

■ Required Facility Water System

<Heat radiation amount / Facility water specifications>

Model	Heat radiation [kW]	Facility water specifications
HRLE050-W-□-□	Approx. 10	Refer to “Facility water system” in the specifications on page 357.
HRLE090-W-□-□	Approx. 20	Refer to “Facility water system” in the specifications on pages 358 and 360.

2. When using tap water as facility water, SMC recommends the water quality shown in the following table as reference.

- In most areas, tap water can be used. However, if the tap water in the area is hard, there is a possibility of failure or performance decline due to limescale build-up. To soften the water and avoid problems, consider using water hardness filters.

Tap Water (as Facility Water) Quality Standards

The Japan Refrigeration and Air Conditioning Industry Association

JRA GL-02-1994 “Cooling water system – Circulation type – Make-up water”

	Item	Unit	Standard value	Influence	
				Corrosion	Scale generation
Standard item	pH (at 25°C)	—	6.5 to 8.2	○	○
	Electric conductivity (25°C)	[μS/cm]	100*1 to 800*1	○	○
	Chloride ion (Cl ⁻)	[mg/L]	200 or less	○	
	Sulfuric acid ion (SO ₄ ²⁻)	[mg/L]	200 or less	○	
	Acid consumption amount (at pH4.8)	[mg/L]	100 or less		○
	Total hardness	[mg/L]	200 or less		○
Reference item	Calcium hardness (CaCO ₃)	[mg/L]	150 or less		○
	Ionic state silica (SiO ₂)	[mg/L]	50 or less		○
	Iron (Fe)	[mg/L]	1.0 or less	○	○
	Copper (Cu)	[mg/L]	0.3 or less	○	
	Sulfide ion (S ₂ ⁻)	[mg/L]	Should not be detected	○	
	Ammonium ion (NH ₄ ⁺)	[mg/L]	1.0 or less	○	
	Residual chlorine (Cl)	[mg/L]	0.3 or less	○	
	Free carbon (CO ₂)	[mg/L]	4.0 or less	○	

*1 In the case of [MΩ·cm], it will be 0.001 to 0.01.

- ○: Factors that have an effect on corrosion or scale generation
- Even if the water quality standards are met, complete prevention of corrosion is not guaranteed.

3. Set the supply pressure between 0.3 to 0.5 MPa. Ensure a pressure difference at the facility water inlet/outlet of 0.3 MPa or more.

If the supply pressure is high, it will cause water leakage. If the supply pressure and pressure difference at the facility water inlet/outlet is low, it will cause an insufficient flow rate of the facility water, and poor temperature control.

Operation

Warning

1. Confirmation before operation

1. The fluid level of a tank should be within the specified range of H (High) and L (Low). When exceeding the specified level, the circulating fluid will overflow.

2. Remove the air.

Conduct a trial operation, looking at the fluid level.

Since the fluid level will go down when the air is removed from the customer’s piping system, supply water once again when the fluid level is reduced. When there is no reduction in the fluid level, the job of removing the air is completed.

2. Confirmation during operation

- Check the circulating fluid temperature.

The operating temperature ranges of the circulating fluid are as follows: 15 to 25°C for CH1, and CH1 + 0 to 15°C for CH2

When the amount of heat generated from the customer equipment is greater than the product’s capability, the circulating fluid temperature may exceed these ranges. Use caution regarding this matter.

3. Emergency stop method

- When an abnormality is confirmed, stop the machine immediately. After stopping operation, disconnect the power supply from the customer equipment.

Operation Restart Time / Operation and Suspension Frequency

Caution

1. Wait five minutes or more before restarting operation after it has been stopped. If the operation is restarted within five minutes, the protection circuit may activate and the operation may not start properly.

2. Operation and suspension frequency should not exceed 10 times per day. Frequently switching between operation and suspension may result in the malfunction of the refrigeration circuit.

Protection Circuit

Caution

If operating in the conditions below, the protection circuit will activate and an operation may not be performed or will stop.

- Power supply voltage is not within the rated voltage range of ±10%.
- In case the water level inside the tank is reduced abnormally
- Circulating fluid temperature is too high.
- Compared to the cooling capacity, the heat generation amount of the customer equipment is too high.
- Ambient temperature is too high. (Check the ambient temperature in the specifications.)
- Ventilation grille is clogged with dust or dirt.



HRLE Series Specific Product Precautions 5

Be sure to read this before handling the products. For safety instructions and temperature control equipment precautions, refer to the “Handling Precautions for SMC Products” and the “Operation Manual” on the SMC website: <https://www.smcworld.com>

Maintenance

⚠ Caution

<Periodical inspection every one month>

Clean the ventilation grille.

If the dustproof filter of air-cooled type product becomes clogged with dust or debris, a decline in cooling performance can result. In order to avoid deforming or damaging the dustproof filter, clean it with a long-haired brush or air gun.

<Periodical inspection every three months>

Inspect the circulating fluid.

1. When using tap water or deionized (pure) water
 - Replacement of circulating fluid
Failure to replace the circulating fluid can lead to the development of bacteria or algae. Replace it regularly depending on your usage conditions.
 - Tank cleaning (same as the HRS series)
Consider whether dirt, slime or foreign matter may be present in the circulating fluid inside the tank, and carry out regular cleanings of the tank.
2. When using ethylene glycol aqueous solution
Use a concentration meter to confirm that the concentration does not exceed 15%.
Dilute or add as needed to adjust the concentration.

<Periodical inspection during the winter season>

1. Make water-removal arrangements beforehand.

If there is a risk of the circulating fluid and facility water freezing when the product is stopped, release the circulating fluid and facility water in advance.

2. Consult a professional.

This product has an “anti-freezing function.” Read the Operation Manual carefully, and if any additional anti-freezing function (e.g. tape heater) is needed, ask for it from the vendor.

■ Refrigerant with GWP reference

Refrigerant	Global Warming Potential (GWP)		
	Regulation (EU) 2024/573, AIM Act 40 CFR Part 84	Fluorocarbon Emissions Control Act (Japan)	
		GWP value labeled on products	GWP value to be used for reporting the calculated amount of leakage
R134a	1,430	1,430	1,300
R404A	3,922	3,920	3,940
R407C	1,774	1,770	1,620
R410A	2,088	2,090	1,920
R448A	1,386	1,390	1,270
R454C	146	145	146

- * This product is hermetically sealed and contains fluorinated greenhouse gases (HFC). When this product is sold on the market in the EU after January 1, 2017, it needs to be compliant with the quota system of the F-Gas Regulation in the EU.
- * See specification table for refrigerant used in the product.