

Guide Rod Slider Type

CE UK CA C AU US
* For details, refer to page 1343 and onward.

LEL Series

RoHS

Size: 25

Incremental (Step Motor 24 VDC)

Low-profile/Flat Height 48 mm

Profile reduced by side mounting of motor

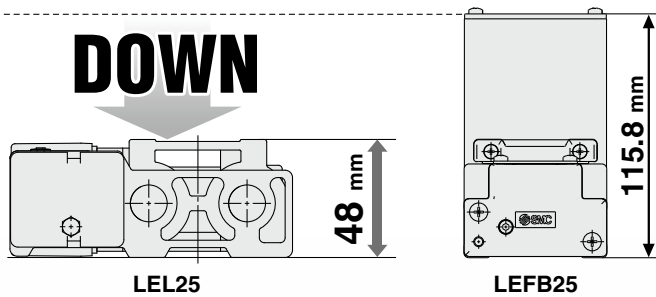

Max. stroke: 1000 mm
Transfer speed: 1000 mm/s

No interference with motor, even with large workpieces!

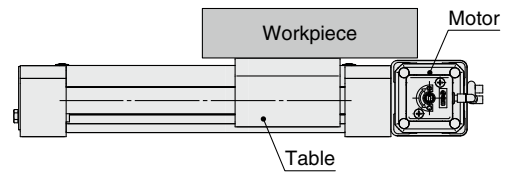

Belt drive
With belt cover

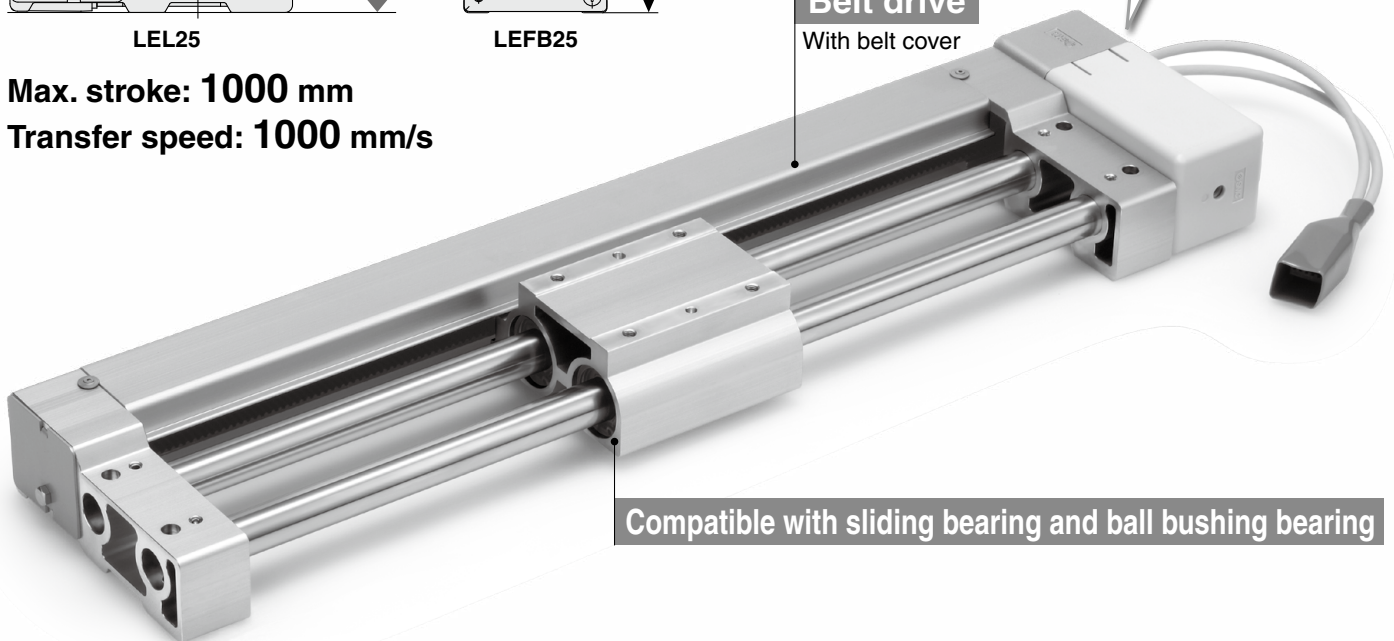

Compatible with sliding bearing and ball bushing bearing

Model	Size	Bearing	Stroke [mm]	Work load (Horizontal) [kg]	Speed [mm/s]	Positioning repeatability [mm]	Page
LEL25M	25	Sliding bearing	Up to 1000	3	Up to 500	±0.08	▶ p. 343
LEL25L		Ball bushing bearing	Up to 1000	5	Up to 1000	±0.08	

Incremental (Step Motor 24 VDC) Controllers

▶ p. 994

▶ Step data input type

JXC51/61 Series

- 64 positioning points
- Input using controller setting kit or teaching box



▶ EtherCAT/ EtherNet/IP™/ PROFINET/ DeviceNet®/ IO-Link/CC-Link direct input type

JXCE□/91/P1/D1/L□/M1 Series



▶ Programless type

LECP1 Series

- 14 positioning points
- Control panel setting



Incremental (Step Motor 24 VDC)

Guide Rod Slider Type Size: 25

Simple construction Guide type can be selected.

Max. stroke: **1000 mm**

Transfer speed: **1000 mm/s**

Guide type

- **Sliding bearing**
Work load: 3 kg (Horizontal)
Reduced noise (60 dB or less) *1
- **Ball bushing bearing**
Work load: 5 kg (Horizontal)
Transfer speed: 1000 mm/s

*1 When the maximum speed is 500 mm/s
(Measured by SMC)



Auto switch mountable (Option: With magnet/switch rail)

For checking the limit and the intermediate signal
Applicable to the D-M9□ and D-M9□W (2-color indicator)

* The auto switches should be ordered separately. Refer to pages 353 and 354 for details.

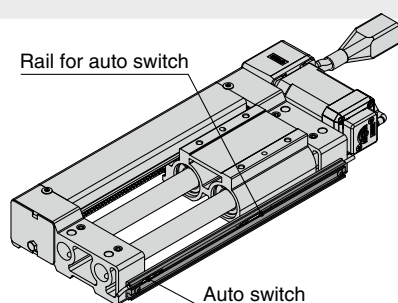

2-color indicator solid state auto switch

Appropriate setting of the mounting position
can be performed without mistakes.

A **green** light
lights up at the
optimum operating
range.

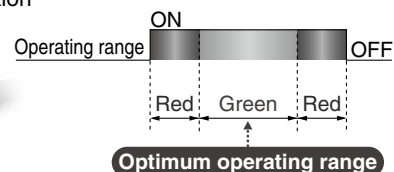

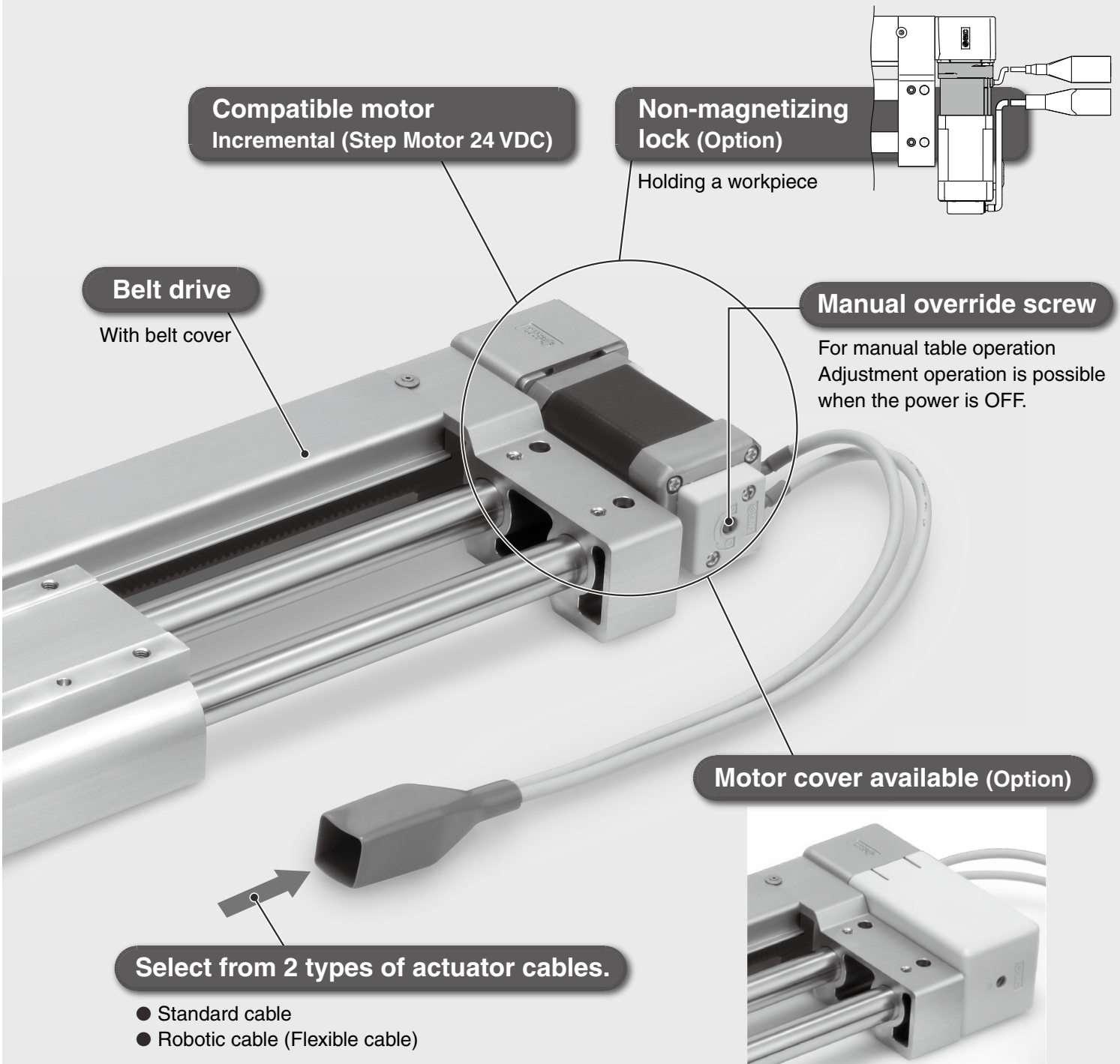

Application Examples

For load and unload transfer of workpieces

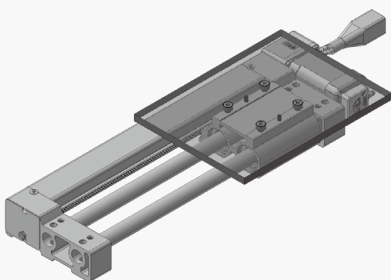

For pick and place operations

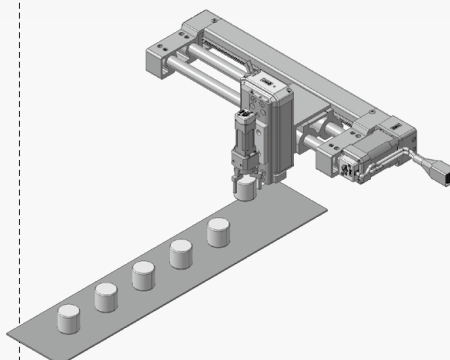

Applications where space is limited

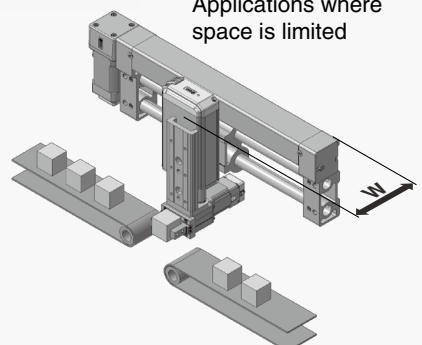

CONTENTS

Incremental (Step Motor 24 VDC)

Guide Rod Slider Type *LEL Series*

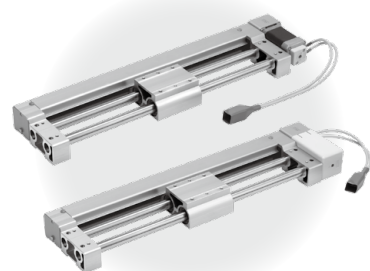

Model Selection	p. 343
How to Order	p. 347
Specifications	p. 350
Construction	p. 351
Dimensions	p. 352
Auto Switch	p. 353
Specific Product Precautions	p. 355

Incremental (Step Motor 24 VDC) Controllers

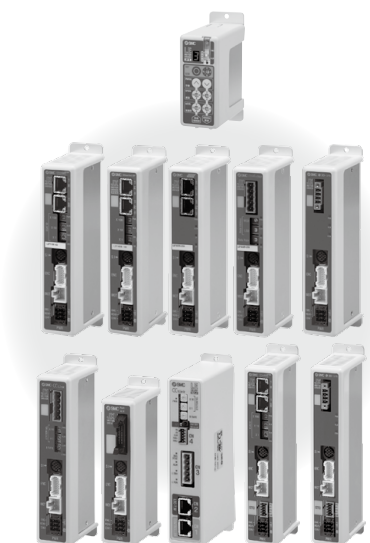

Step Data Input Type/ <i>JXC51/61 Series</i>	p. 1017
EtherCAT/EtherNet/IP™/PROFINET/DeviceNet®/IO-Link/CC-Link Direct Input Type/ <i>JXCE□/91/P1/D1/L□/M1 Series</i>	p. 1063
Gateway Unit/ <i>LEC-G Series</i>	p. 1038
Programless Controller/ <i>LECP1 Series</i>	p. 1042
Actuator Cable	p. 1092
Communication Cable for Controller Setting/ <i>LEC-W2A-□</i>	p. 1094
Teaching Box/ <i>LEC-T1</i>	p. 1095

Guide Rod Slider Type

LEL Series

Incremental (Step Motor 24 VDC)

p. 347



Controllers/Drivers p. 994

Model Selection



LEL Series ▶ p. 347

Selection Procedure



Selection Example

Operating conditions

- Workpiece mass: 4 [kg]
- Speed: 300 [mm/s]
- Acceleration/Deceleration: 3000 [mm/s²]
- Stroke: 500 [mm]
- Mounting position: Horizontal upward

• Workpiece mounting condition:

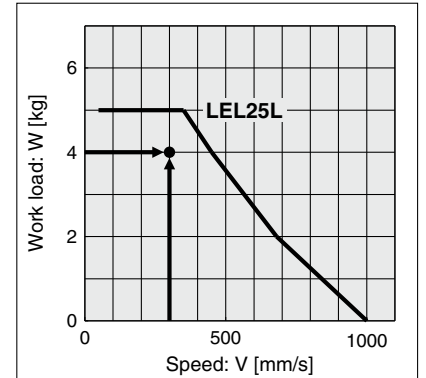
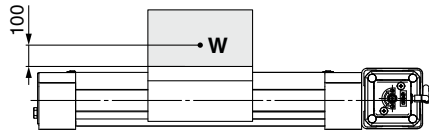

<Speed-Work load graph>
(LEL25L/Step motor)

Step 1 Check the work load-speed. <Speed-Work load graph> (Page 346)

Select a model based on the workpiece mass and speed while referencing the speed-work load graph.

Selection example) The LEL25LT-500 can be temporarily selected as a possible candidate based on the graph shown on the right side.

Step 2 Check the cycle time.

Calculate the cycle time using the following calculation method.

Cycle time:

T can be found from the following equation.

$$T = T1 + T2 + T3 + T4 \text{ [s]}$$

- T1: Acceleration time and T3: Deceleration time can be found by the following equation.

$$T1 = V/a1 \text{ [s]}$$

$$T3 = V/a2 \text{ [s]}$$

- T2: Constant speed time can be found from the following equation.

$$T2 = \frac{L - 0.5 \cdot V \cdot (T1 + T3)}{V} \text{ [s]}$$

- T4: Settling time varies depending on the conditions such as motor types, load and in position of the step data. Therefore, calculate the settling time while referencing the following value.

$$T4 = 0.3 \text{ [s]}$$

Calculation example)

T1 to T4 can be calculated as follows.

$$T1 = V/a1 = 300/3000 = 0.1 \text{ [s]}$$

$$T3 = V/a2 = 300/3000 = 0.1 \text{ [s]}$$

$$T2 = \frac{L - 0.5 \cdot V \cdot (T1 + T3)}{V} = \frac{500 - 0.5 \cdot 300 \cdot (0.1 + 0.1)}{300} = 1.57 \text{ [s]}$$

$$T4 = 0.3 \text{ [s]}$$

The cycle time can be found as follows.

$$T = T1 + T2 + T3 + T4 = 0.1 + 1.57 + 0.1 + 0.3 = 2.07 \text{ [s]}$$

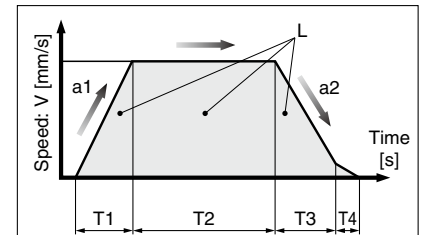

- L : Stroke [mm] ... (Operating condition)
- V : Speed [mm/s] ... (Operating condition)
- a1: Acceleration [mm/s²] ... (Operating condition)
- a2: Deceleration [mm/s²] ... (Operating condition)

- T1: Acceleration time [s]
Time until reaching the set speed
- T2: Constant speed time [s]
Time while the actuator is operating at a constant speed
- T3: Deceleration time [s]
Time from the beginning of the constant speed operation to stop
- T4: Settling time [s]
Time until positioning is completed

Step 3 Check the guide moment.

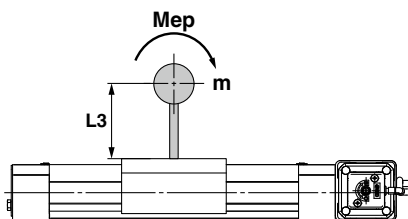

Based on the above calculation result, the LEL25LT-500 should be selected.

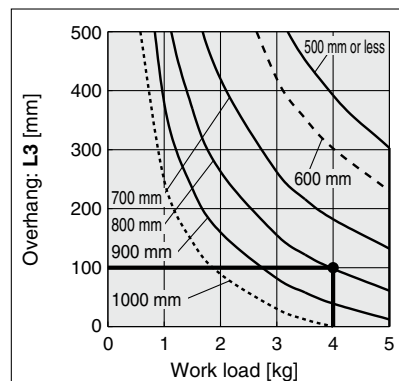

Dynamic Allowable Moment

* These graphs show the amount of allowable overhang (guide unit) when the center of gravity of the workpiece overhangs in one direction. When selecting the overhang, refer to the "Calculation of Guide Load Factor" or the Electric Actuator Model Selection Software for confirmation: <https://www.smcworld.com>

Acceleration/Deceleration — 3000 mm/s²

Orientation		Load overhanging direction	Model	
		m: Work load [kg] L: Overhang to the work load center of gravity [mm]	LEL25M	LEL25L
Horizontal/Bottom mounting	X			
	Y			
	Z			
Wall mounting	X			
	Y			
	Z			

Calculation of Guide Load Factor

- Decide operating conditions.

Model: LEL

Size: 25

Mounting orientation: Horizontal/Bottom/Wall

Acceleration [mm/s^2]: **a**

Work load [kg]: **m**

Work load center position [mm]: **Xc/Yc/Zc**

- Select the target graph while referencing the model, size, and mounting orientation.

- Based on the acceleration and work load, find the overhang [mm]: **Lx/Ly/Lz** from the graph.

- Calculate the load factor for each direction.

$$\alpha_x = X_c/L_x, \alpha_y = Y_c/L_y, \alpha_z = Z_c/L_z$$

- Confirm the total of α_x , α_y , and α_z is 1 or less.

$$\alpha_x + \alpha_y + \alpha_z \leq 1$$

When 1 is exceeded, please consider a reduction of acceleration and work load, or a change of the work load center position and series.

Mounting orientation

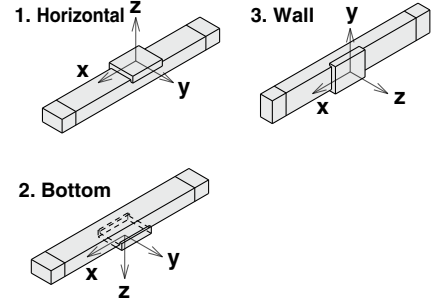

Example

- Operating conditions

Model: LEL

Size: 25L

Stroke: 500

Mounting orientation: Horizontal

Acceleration [mm/s^2]: 3000

Work load [kg]: 4

Work load center position [mm]: **Xc = 30, Yc = 20, Zc = 100**

3. **Lx = 120 mm, Ly = 65 mm, Lz = 390 mm**

- The load factor for each direction can be found as follows.

$$\alpha_x = 30/120 = 0.25$$

$$\alpha_y = 20/65 = 0.31$$

$$\alpha_z = 100/390 = 0.26$$

- Select three graphs from the top of the right side on page 344.

- $\alpha_x + \alpha_y + \alpha_z = 0.82 \leq 1$**

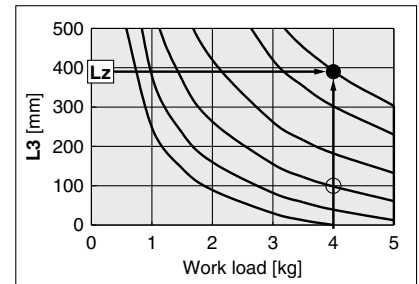
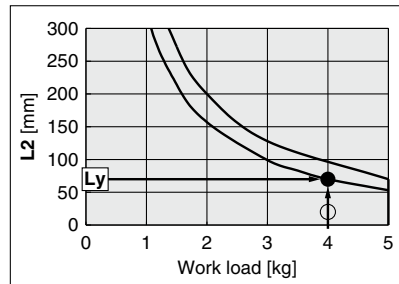
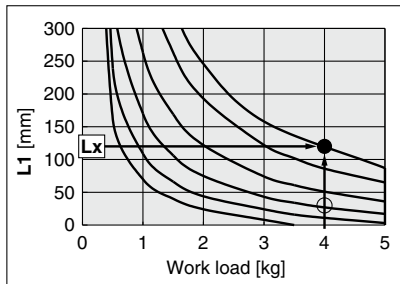

Speed-Work Load Graph (Guide)

LEL25M

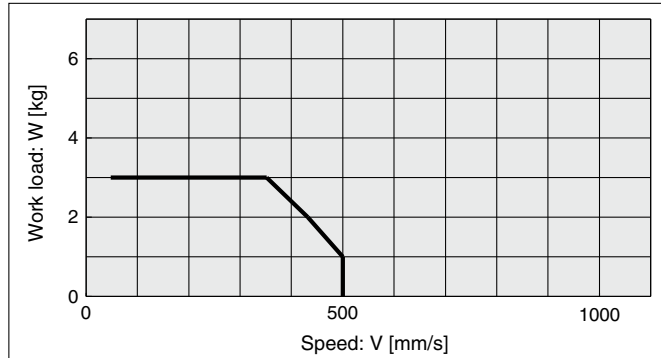

LEL25L

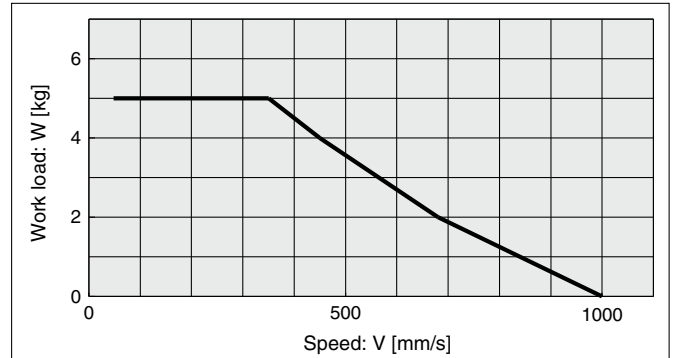
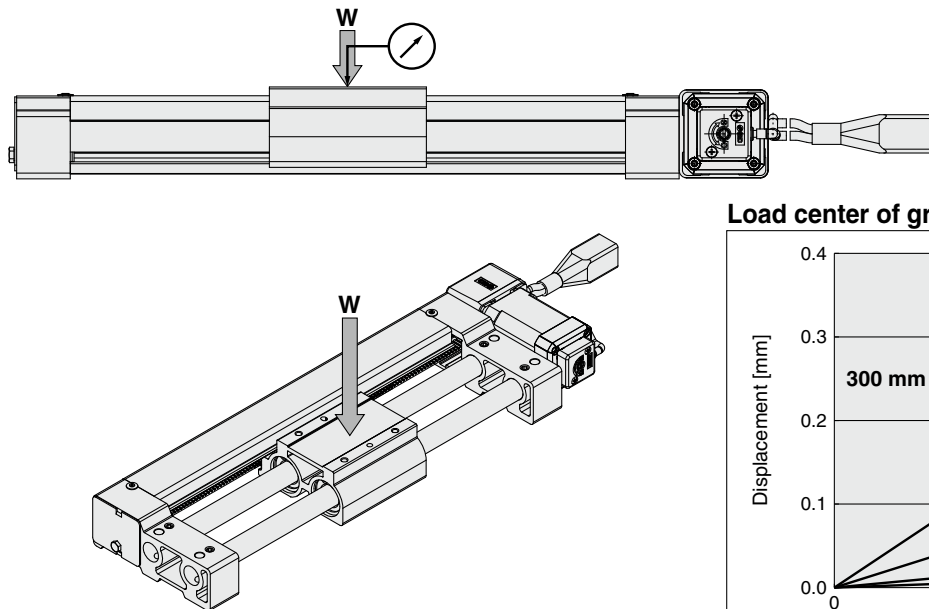

Table Displacement (Reference Value)

* Amount of displacement of the table when the load center of gravity is located at the table center in the middle of the stroke.



Load center of gravity located at the center of the table

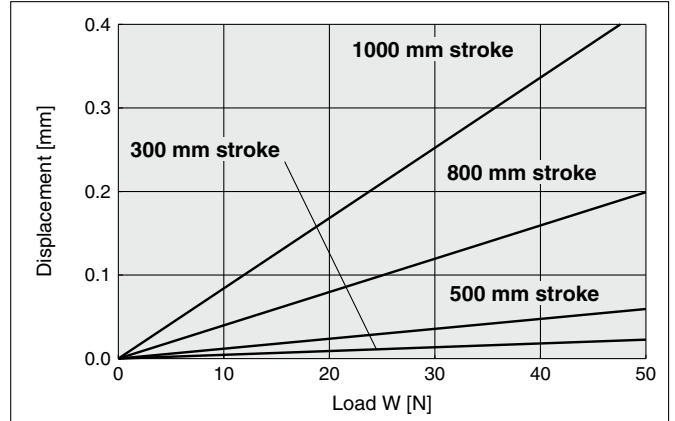
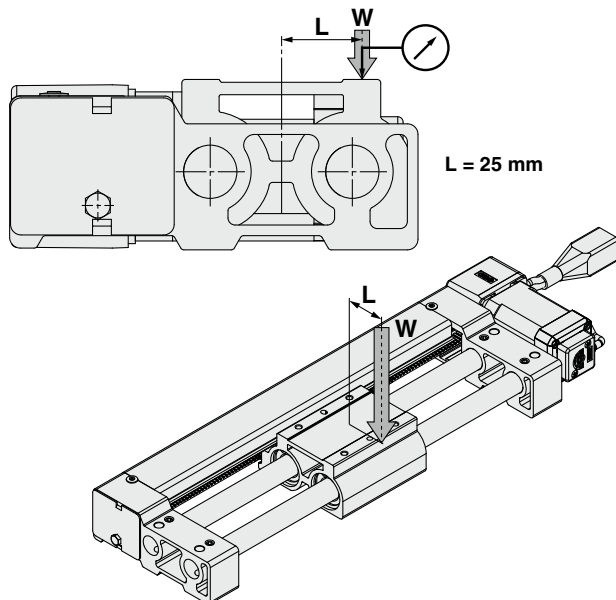
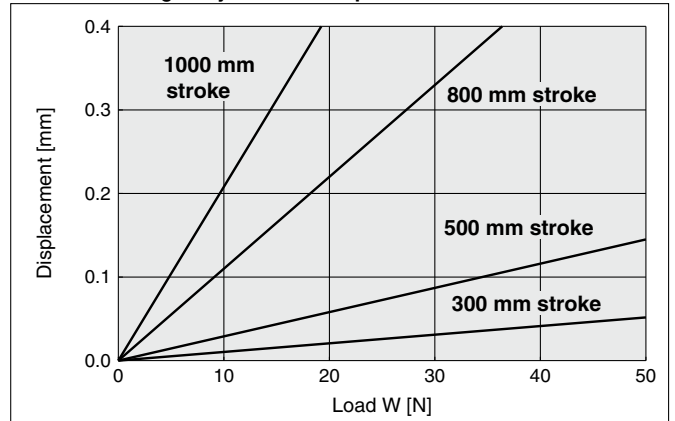

Table Displacement (Reference Value)

* Amount of displacement when the load is offset by "L" from the center of the table.



Load center of gravity located at a position offset when L = 25 mm



Guide Rod Slider Type Belt Drive

LEL Series LEL25



* For details, refer to page 1343 and onward.



How to Order

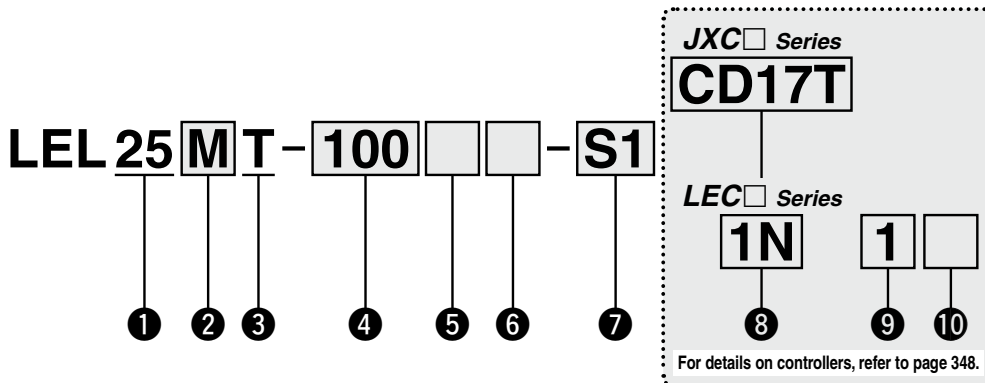

1 Size

25

2 Bearing type

M	Sliding bearing
L	Ball bushing bearing

3 Equivalent lead

T	48 mm
---	-------

4 Stroke*1 *2 [mm]

Stroke	None	
	Size	Applicable stroke
100 to 1000	25	100, 200, 300, 400, 500, 600, 700, 800, 900, 1000 (100 mm increments)

5 Motor option

Nil	Without option
B	With lock
C	With motor cover*3

6 Switch rail option*4

Nil	Without option
R	With magnet/switch rail

7 Actuator cable type/length*6

Standard cable [m]		Robotic cable [m]			
Nil	None	R1	1.5	RA	10*5
S1	1.5	R3	3	RB	15*5
S3	3	R5	5	RC	20*5
S5	5	R8	8*5		



JXC Series (For details, refer to page 349.)

8 Controller

Nil	Without controller
C□1□□	With controller

C D 1 7 T

Interface (Communication protocol/Input/Output)

Symbol	Type	Number of axes, Special specification	
		Standard	With STO sub-function
5	Parallel input (NPN)	●	
6	Parallel input (PNP)	●	
E	EtherCAT	●	●
9	EtherNet/IP™	●	●
P	PROFINET	●	●
D	DeviceNet®	●	
L	IO-Link	●	●
M	CC-Link	●	

Mounting

7	Screw mounting
8*10	DIN rail

Number of axes, Special specification

Symbol	Number of axes	Specification
1	Single axis	Standard
F	Single axis	With STO sub-function

Communication plug connector, I/O cable*11

Symbol	Type	Applicable interface
Nil	Without accessory	—
S	Straight type communication plug connector	DeviceNet®
T	T-branch type communication plug connector	CC-Link Ver. 1.10
1	I/O cable (1.5 m)	Parallel input (NPN) Parallel input (PNP)
3	I/O cable (3 m)	
5	I/O cable (5 m)	

LEC Series (For details, refer to page 349.)

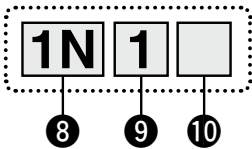

8 Controller type*7

Nil	Without controller	
1N	LECP1 (Programless type)	NPN
1P		PNP

9 I/O cable length*8

Nil	Without cable (Without communication plug connector)	
1	1.5 m	
3	3 m*9	
5	5 m*9	

10 Controller mounting

Nil	Screw mounting
D	DIN rail*10



- *1 Please contact SMC as all non-standard and non-made-to-order strokes are produced as special orders.
- *2 The strokes in bold are produced upon receipt of order.
- *3 When [With lock] is selected, [With motor cover] cannot be selected.
- *4 After purchasing the "Nil" type, the magnet and switch rail cannot be attached afterwards.
- *5 Produced upon receipt of order (Robotic cable only)
- *6 The standard cable should only be used on fixed parts. For use on moving parts, select the robotic cable. Refer to page 1092 if only the actuator cable is required.
- *7 For details on controllers and compatible motors, refer to the compatible controllers on the next page.

- *8 When "Without controller" is selected for controller types, I/O cable length cannot be selected.
- *9 When "Pulse input type" is selected for controller/driver types, pulse input usable only with differential. Only 1.5 m cables usable with open collector
- *10 The DIN rail is not included. It must be ordered separately.
- *11 Select "Nil" for anything other than DeviceNet®, CC-Link, or parallel input. Select "Nil," "S," or "T" for DeviceNet® or CC-Link. Select "Nil," "1," "3," or "5" for parallel input.

⚠ Caution

[CE/UKCA-compliant products]

① EMC compliance was tested by combining the electric actuator LEL series and the controller LEC/JXC series. The EMC depends on the configuration of the customer's control panel and the relationship with other electrical equipment and wiring. Therefore, compliance with the EMC directive cannot be certified for SMC components incorporated into the customer's equipment under actual operating conditions. As a result, it is necessary for the customer to verify compliance with the EMC directive for the machinery and equipment as a whole.

[UL-compliant products (For the LEC series)]

When compliance with UL is required, the electric actuator and controller/driver should be used with a UL1310 Class 2 power supply.

The actuator and controller/driver are sold as a package.

Confirm that the combination of the controller/driver and the actuator is correct.

<Check the following before use.>

- ① Check the actuator label for the model number. This number should match that of the controller/driver.
- ② Check that the Parallel I/O configuration matches (NPN or PNP).

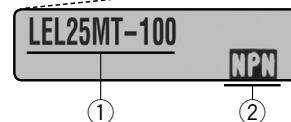













* Refer to the Operation Manual for using the products. Please download it via our website: <https://www.smcworld.com>

LEL Series

Incremental (Step Motor 24 VDC)

Compatible Controllers

Type	Step data input type	Programless type
		
Series	JXC51 JXC61	LECP1
Features	Parallel I/O	Capable of setting up operation (step data) without using a PC or teaching box
Compatible motor	Step motor (Servo/24 VDC)	
Max. number of step data	64 points	14 points
Power supply voltage	24 VDC	
Reference page	1017	1042

Type	EtherCAT direct input type	EtherCAT direct input type with STO sub-function	EtherNet/IP™ direct input type	EtherNet/IP™ direct input type with STO sub-function	PROFINET direct input type	PROFINET direct input type with STO sub-function	DeviceNet® direct input type	IO-Link direct input type	IO-Link direct input type with STO sub-function	CC-Link direct input type
										
Series	JXCE1	JXCEF	JXC91	JXC9F	JXCP1	JXC PF	JXCD1	JXCL1	JXCLF	JXCM1
Features	EtherCAT direct input	EtherCAT direct input with STO sub-function	EtherNet/IP™ direct input	EtherNet/IP™ direct input with STO sub-function	PROFINET direct input	PROFINET direct input with STO sub-function	DeviceNet® direct input	IO-Link direct input	IO-Link direct input with STO sub-function	CC-Link direct input
Compatible motor	Step motor (Servo/24 VDC)									
Max. number of step data	64 points									
Power supply voltage	24 VDC									
Reference page	1063									

Specifications

Step Motor (Servo/24 VDC)

Model		LEL25M	LEL25L
Actuator specifications	Stroke [mm] ^{*1}	(100), (200), 300, 400, 500, 600 (700), (800), (900), (1000)	
	Work load [kg] ^{*2}	3 (2.5)	5 (5)
	Speed [mm/s] ^{*2}	48 to 500	48 to 1000
	Max. acceleration/deceleration [mm/s ²]	3000	
	Positioning repeatability [mm]	±0.08	
	Lost motion [mm] ^{*3}	0.1 or less	
	Equivalent lead [mm]	48	
	Impact/Vibration resistance [m/s ²] ^{*4}	50/20	
	Actuation type	Belt	
	Guide type	Sliding bearing	Ball bushing bearing
	Allowable external force [N] ^{*5}	5	
	Operating temperature range [°C]	5 to 40	
	Operating humidity range [%RH]	90 or less (No condensation)	
Electric specifications	Enclosure	IP10	
	Motor size	□42	
	Motor type	Step motor (Servo/24 VDC)	
	Encoder	Incremental	
	Power supply voltage [V]	24 VDC ±10%	
Lock unit specifications	Power [W] ^{*6 *8}	Max. power 60	
	Type ^{*7}	Non-magnetizing lock	
	Holding force [N]	19	
	Power consumption [W] ^{*8}	5	
Rated voltage [V]	24 VDC ±10%		

*1 Strokes shown in () are produced upon receipt of order. Please contact SMC as all non-standard and non-made-to-order strokes are produced as special orders.

*2 Speed changes according to the work load. Check the "Speed-Work Load Graph (Guide)" on page 346. The work load changes according to the stroke and work load mounting condition.

Check the "Dynamic Allowable Moment" graph on page 344. Furthermore, if the cable length exceeds 5 m, then it will decrease by up to 10% for each 5 m.

*3 A reference value for correcting errors in reciprocal operation

*4 Impact resistance: No malfunction occurred when the actuator was tested with a drop tester in both the stroke direction and a perpendicular direction to the stroke. (The test was performed with the actuator in the initial state.)

Vibration resistance: No malfunction occurred in a test ranging between 45 to 2000 Hz, when the actuator was tested in both stroke direction and a perpendicular direction to the stroke. (The test was performed with the actuator in the initial state.)

*5 Allowable external resistance is the allowable resistance when flexible moving tube or similar is used.

*6 Indicates the max. power during operation (including the controller)

This value can be used for the selection of the power supply.

*7 With lock only

*8 For an actuator with lock, add the power consumption for the lock.

Actuator Product Weight

Stroke [mm]		(100)	(200)	300	400	500	600	(700)	(800)	(900)	(1000)
Product weight [kg]	LEL25M	2.13	2.47	2.82	3.17	3.52	3.87	4.21	4.56	4.91	5.26
	LEL25L	2.38	2.72	3.07	3.42	3.77	4.12	4.47	4.82	5.17	5.52
Additional weight with lock [kg]		0.26									
Additional weight with cover [kg]		0.04									

LEL Series

Incremental (Step Motor 24 VDC)

Construction

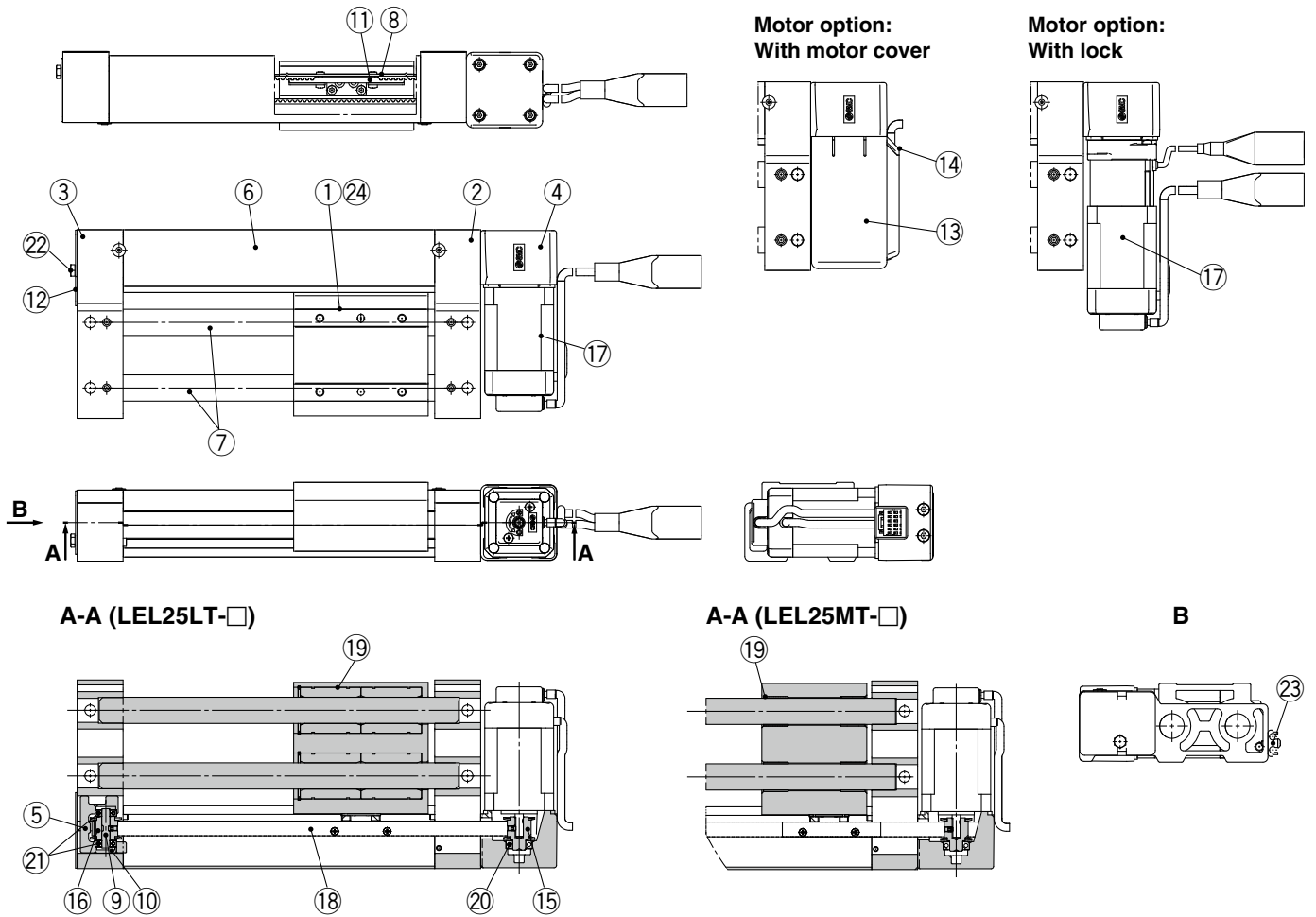

Component Parts

No.	Description	Material	Note
1	Table	Aluminum alloy	Anodized
2	Motor end plate	Aluminum alloy	Anodized
3	End plate	Aluminum alloy	Anodized
4	Motor mount	Aluminum die-cast	Painting
5	Pulley holder	Aluminum alloy	
6	Belt cover	Aluminum alloy	Anodized
7	Guide rod	Carbon steel	Hard chrome plating
8	Belt holder	Carbon steel	Chromating
9	Pulley shaft	Stainless steel	
10	Spacer	Aluminum alloy	
11	Belt stopper	Aluminum alloy	
12	Tension plate	Aluminum alloy	Anodized
13	Motor cover	Synthetic resin	"With motor cover" only
14	Grommet	Synthetic resin	"With motor cover" only
15	Motor pulley	Aluminum alloy	Anodized
16	End pulley	Aluminum alloy	Anodized
17	Motor	—	
18	Belt	—	
19	Bushing	—	
	Ball bushing bearing	—	
20	Bearing	—	
21	Bearing	—	
22	Hexagon bolt	Carbon steel	Chromating
23	Switch rail	Aluminum alloy	"With magnet/switch rail" only
24	Magnet	—	"With magnet/switch rail" only

Dimensions

LEL25^M_LT

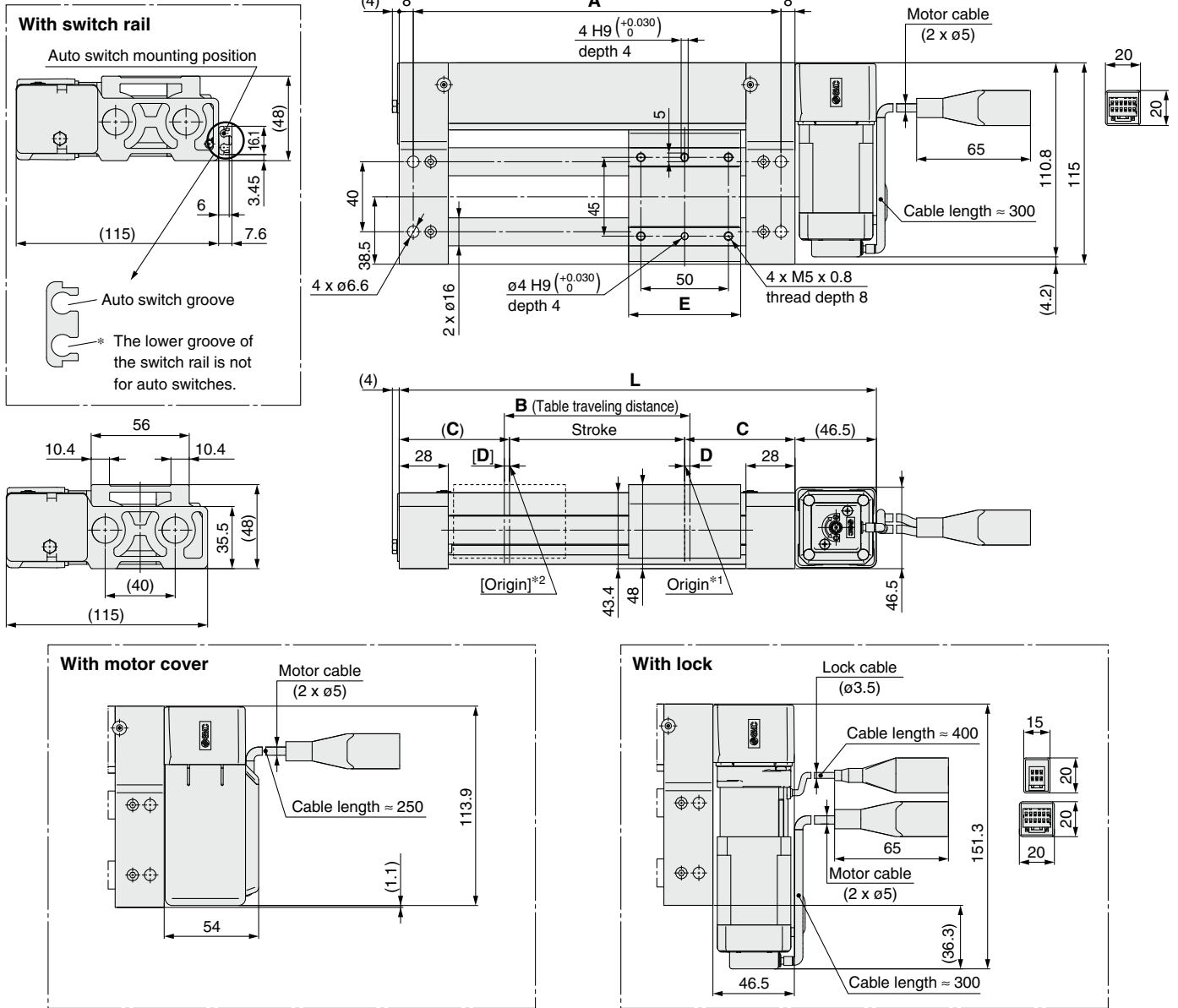

- *1 Position after returning to origin
- *2 [] for when the direction of return to origin has changed
- * This is the distance within which the table can move when it returns to origin. Make sure that workpieces mounted on the table do not interfere with other workpieces or the facilities around the table.

Model	L	L* ₃	A	B	C	D	E
LEL25MT-100□□-□□□□	272.5	280	210	106	63	3	64
LEL25MT-200□□-□□□□	372.5	380	310	206			
LEL25MT-300□□-□□□□	472.5	480	410	306			
LEL25MT-400□□-□□□□	572.5	580	510	406			
LEL25MT-500□□-□□□□	672.5	680	610	506			
LEL25MT-600□□-□□□□	772.5	780	710	606			
LEL25MT-700□□-□□□□	872.5	880	810	706			
LEL25MT-800□□-□□□□	972.5	980	910	806			
LEL25MT-900□□-□□□□	1072.5	1080	1010	906			
LEL25MT-1000□□-□□□□	1172.5	1180	1110	1006			
LEL25LT-100□□-□□□□	292.5	300	230	108	73	4	82
LEL25LT-200□□-□□□□	392.5	400	330	208			
LEL25LT-300□□-□□□□	492.5	500	430	308			
LEL25LT-400□□-□□□□	592.5	600	530	408			
LEL25LT-500□□-□□□□	692.5	700	630	508			
LEL25LT-600□□-□□□□	792.5	800	730	608			
LEL25LT-700□□-□□□□	892.5	900	830	708			
LEL25LT-800□□-□□□□	992.5	1000	930	808			
LEL25LT-900□□-□□□□	1092.5	1100	1030	908			
LEL25LT-1000□□-□□□□	1192.5	1200	1130	1008			

*3 With motor cover

Solid State Auto Switch Direct Mounting Type D-M9N(V)/D-M9P(V)/D-M9B(V)

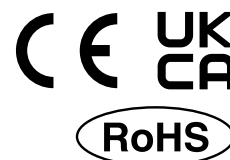

Refer to the SMC website for details on products that are compliant with international standards.

Auto Switch Specifications

PLC: Programmable Logic Controller

D-M9□, D-M9□V (With indicator light)						
Auto switch model	D-M9N	D-M9NV	D-M9P	D-M9PV	D-M9B	D-M9BV
Electrical entry direction	In-line	Perpendicular	In-line	Perpendicular	In-line	Perpendicular
Wiring type	3-wire				2-wire	
Output type	NPN		PNP		—	
Applicable load	IC circuit, Relay, PLC				24 VDC relay, PLC	
Power supply voltage	5, 12, 24 VDC (4.5 to 28 V)				—	
Current consumption	10 mA or less				—	
Load voltage	28 VDC or less		—		24 VDC (10 to 28 VDC)	
Load current	40 mA or less				2.5 to 40 mA	
Internal voltage drop	0.8 V or less at 10 mA (2 V or less at 40 mA)				4 V or less	
Leakage current	100 μA or less at 24 VDC				0.8 mA or less	
Indicator light	Red LED illuminates when turned ON.					
Standard	CE/UKCA marking					

Grommet

- 2-wire load current is reduced (2.5 to 40 mA).
- Using flexible cable as standard spec.



Oilproof Flexible Heavy-duty Lead Wire Specifications

Auto switch model	D-M9N(V)	D-M9P(V)	D-M9B(V)
Sheath	Outside diameter [mm] $\phi 2.6$		
Insulator	Number of cores		2 cores (Brown/Blue)
	Outside diameter [mm]		$\phi 0.88$
Conductor	Effective area [mm ²]		0.15
	Strand diameter [mm]		$\phi 0.05$
Min. bending radius [mm] (Reference values)			
17			

- * Refer to page 1363 for solid state auto switch common specifications.
- * Refer to page 1363 for lead wire lengths.

Caution

Precautions

Fix the auto switch with the existing screw installed on the auto switch body. The auto switch may be damaged if a screw other than the one supplied is used.

Weight

[g]

Auto switch model	D-M9N(V)	D-M9P(V)	D-M9B(V)
Lead wire length	0.5 m (Nil)	8	7
	1 m (M)	14	13
	3 m (L)	41	38
	5 m (Z)	68	63

Dimensions

[mm]

D-M9□

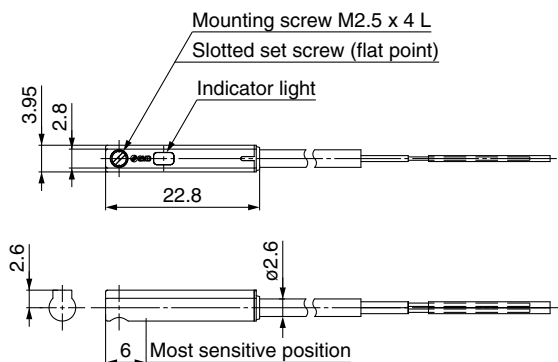

D-M9□V

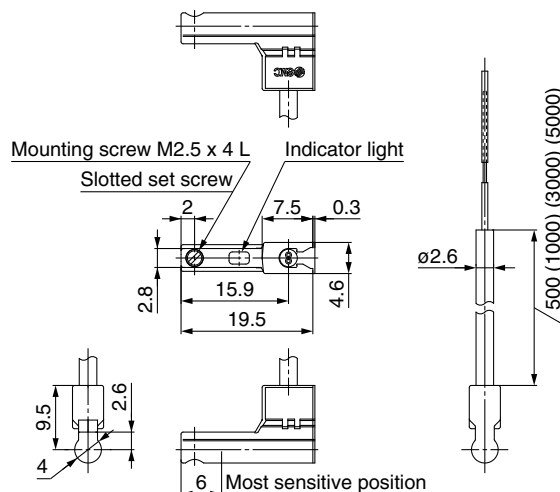

2-Color Indicator Solid State Auto Switch Direct Mounting Type D-M9NW(V)/D-M9PW(V)/D-M9BW(V)



Refer to the SMC website for details on products that are compliant with international standards.

Auto Switch Specifications

PLC: Programmable Logic Controller

D-M9□W, D-M9□WV (With indicator light)						
Auto switch model	D-M9NW	D-M9NWV	D-M9PW	D-M9PWV	D-M9BW	D-M9BWV
Electrical entry direction	In-line	Perpendicular	In-line	Perpendicular	In-line	Perpendicular
Wiring type	3-wire				2-wire	
Output type	NPN		PNP		—	
Applicable load	IC circuit, Relay, PLC				24 VDC relay, PLC	
Power supply voltage	5, 12, 24 VDC (4.5 to 28 V)				—	
Current consumption	10 mA or less				—	
Load voltage	28 VDC or less		—		24 VDC (10 to 28 VDC)	
Load current	40 mA or less				2.5 to 40 mA	
Internal voltage drop	0.8 V or less at 10 mA (2 V or less at 40 mA)				4 V or less	
Leakage current	100 μA or less at 24 VDC				0.8 mA or less	
Indicator light	Operating range Red LED illuminates. Proper operating range Green LED illuminates.					
Standard	CE/UKCA marking					

Grommet

- 2-wire load current is reduced (2.5 to 40 mA).
- Using flexible cable as standard spec.
- The proper operating range can be determined by the color of the light. (Red → Green ← Red)

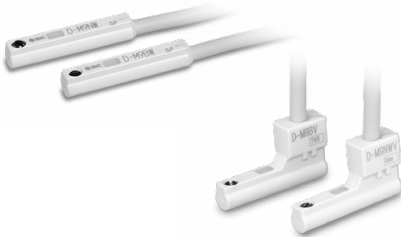

Caution

Precautions

Fix the auto switch with the existing screw installed on the auto switch body. The auto switch may be damaged if a screw other than the one supplied is used.

Oilproof Flexible Heavy-duty Lead Wire Specifications

Auto switch model		D-M9NW(V)	D-M9PW(V)	D-M9BW(V)
Sheath	Outside diameter [mm]	ø2.6		
Insulator	Number of cores	3 cores (Brown/Blue/Black)		2 cores (Brown/Blue)
	Outside diameter [mm]	ø0.88		
Conductor	Effective area [mm ²]	0.15		
	Strand diameter [mm]	ø0.05		
Min. bending radius [mm] (Reference values)		17		

- * Refer to page 1363 for solid state auto switch common specifications.
- * Refer to page 1363 for lead wire lengths.

Weight

[g]

Auto switch model		D-M9NW(V)	D-M9PW(V)	D-M9BW(V)
Lead wire length	0.5 m (Nil)	8	7	7
	1 m (M)	14	13	13
	3 m (L)	41	38	38
	5 m (Z)	68	63	63

Dimensions

[mm]

D-M9□W

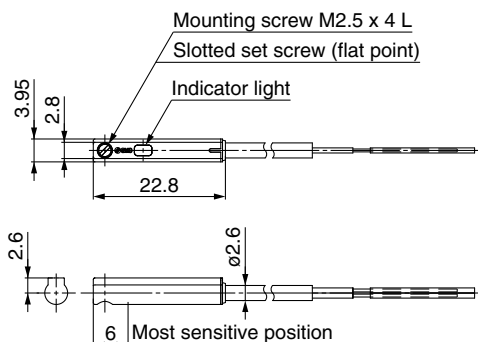

D-M9□WV

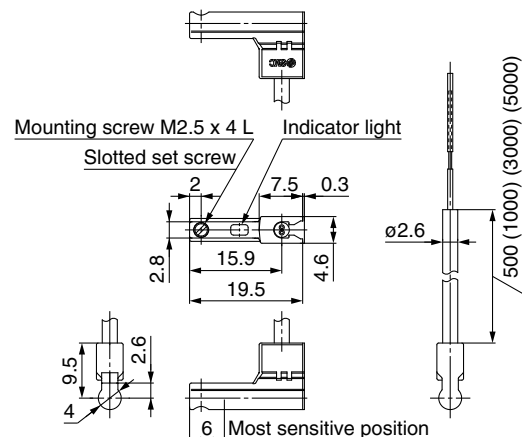



LEL Series Specific Product Precautions 1

Be sure to read this before handling the products. Refer to page 1351 for safety instructions, pages 1352 to 1357 for electric actuator precautions, and pages 1358 to 1367 for auto switch precautions.

Design

⚠ Caution

- 1. Do not apply a load in excess of the specification limits.**
Select a suitable actuator by work load and allowable moment. If a load in excess of the specification limits is applied to the guide, adverse effects such as the generation of play in the guide, reduced accuracy, or reduced service life of the product may occur. And also when "With magnet/switch rail" option is selected, Auto switch may not detect correctly by the deflection of the guide.
- 2. Do not use the product in applications where excessive external force or impact force is applied to it.**
This can cause a malfunction.
- 3. Because of the guide mechanism type, vibration that comes from an external source may be introduced into the workpiece during operation. Do not use this product in a location where vibration is not allowed.**
- 4. When the product repeatedly cycles with partial strokes (see the table below), operate it at a full stroke at least once every few dozen cycles.**
Failure to do so may result in the product running out of lubrication.

Model	Partial stroke
LEL25L	40 mm or less

Handling

⚠ Caution

- 1. Set the [In position] in the step data to at least 1.**
If it is set any lower, the completion signal of the [In position] may not be properly output.
- 2. INP output signal**
 - 1) Positioning operation
When the product comes within the set range of the step data [In position], the INP output signal will turn ON.
Initial value: Set to [1] or higher.

Handling

⚠ Caution

- 3. Never allow the table to collide with the stroke end except during return to origin.**
When incorrect instructions are inputted, such as those which cause the product to operate outside of the specification limits or outside of the actual stroke through changes in the controller/driver settings and/or origin position, the table may collide with the stroke end of the actuator. Be sure to check these points before use.
If the table collides with the stroke end of the actuator, the guide, belt, or internal stopper may break. This can result in abnormal operation.

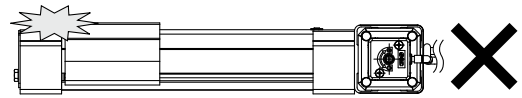

- 4. The moving force should be the initial value (100%).**
If the moving force is set below the initial value, it may cause the generation of an alarm.
- 5. The actual speed of this actuator is affected by the work load.**
Check the model selection section of the catalog.
- 6. Do not apply a load, impact or resistance in addition to the transferred load during return to origin.**
Additional force will cause the displacement of the origin position since it is based on the detected motor torque.
- 7. Do not dent, scratch, or cause other damage to the body or table mounting surfaces.**
Doing so may cause unevenness in the mounting surface, play in the guide, or an increase in the sliding resistance.
- 8. Do not apply strong impact or an excessive moment while mounting a workpiece.**
If an external force over the allowable moment is applied, it may cause play in the guide or an increase in the sliding resistance.
- 9. Keep the flatness of the mounting surface within 0.2 mm.**
If a workpiece or base does not sit evenly on the body of the product, play in the guide, or an increase in the sliding resistance may occur.
- 10. When mounting the product, secure a bending diameter of 40 mm or longer for the cable.**
- 11. Do not allow a workpiece to collide with the table during the positioning operation or within the positioning range.**
- 12. Hold by the end plates when moving the body. Do not hold the belt cover.**



LEL Series Specific Product Precautions 2

Be sure to read this before handling the products. Refer to page 1351 for safety instructions, pages 1352 to 1357 for electric actuator precautions, and pages 1358 to 1367 for auto switch precautions.

Handling

Caution

13. When mounting the product, use screws of adequate length and tighten them with adequate torque.

Tightening the screws with a higher torque than recommended may result in a malfunction, while tightening with a lower torque can result in the displacement of the mounting position or, in extreme conditions, the actuator could become detached from its mounting position.

Body fixed

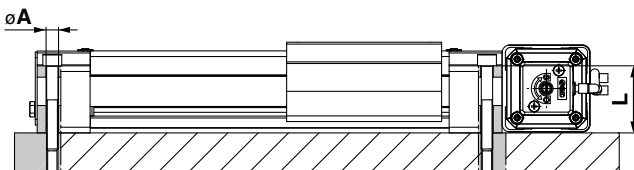

Model	Screw size	Max. tightening torque [N·m]	øA [mm]	L [mm]
LEL25	M6	5.2	6.6	35.5

Workpiece fixed

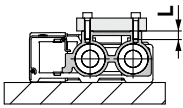

Model	Screw size	Max. tightening torque [N·m]	L (Max. screw-in depth) [mm]
LEL25	M5 x 0.8	3	8

To prevent the workpiece retaining screws from touching the body, use screws that are 0.5 mm or shorter than the maximum screw-in depth. If long screws are used, they may touch the body and cause a malfunction.

14. Do not operate by fixing the table and moving the actuator body.

15. The belt drive actuator cannot be used for vertical applications.

16. Check the specifications for the minimum speed of each actuator.

Failure to do so may result in unexpected malfunctions such as knocking.

17. In the case of the belt drive actuator, vibration may occur during operation at speeds within the actuator specifications due to the operating conditions. Change the speed setting to a speed that does not cause vibration.

Maintenance

Warning

Maintenance frequency

Perform maintenance according to the table below.

Frequency	Appearance check	Internal check	Belt check
Inspection before daily operation	○	—	—
Inspection every 6 months/1000 km/5 million cycles*1	○	○	○

*1 Select whichever comes first.

• Items for visual appearance check

1. Loose set screws, Abnormal amount of dirt, etc.
2. Check for visible damage, Check of cable joint
3. Vibration, Noise

• Items for internal check

1. Lubricant condition on moving parts
2. Loose or mechanical play in fixed parts or fixing screws

• Items for belt check

Stop operation immediately and replace the belt when any of the following occur. In addition, ensure your operating environment and conditions satisfy the requirements specified for the product.

a. Tooth shape canvas is worn out

Canvas fiber becomes fuzzy, Rubber is coming off and the fiber has become whitish, Lines of fibers have become unclear

b. Peeling off or wearing of the side of the belt

Belt corner has become rounded and frayed threads stick out

c. Belt partially cut

Belt is partially cut, Foreign matter caught in the teeth of other parts is causing damage

d. A vertical line on belt teeth is visible

Damage which is made when the belt runs on the flange

e. Rubber back of the belt is softened and sticky

f. Cracks on the back of the belt are visible