

# Slide Tables

## LES/LESH Series



\* For details, refer to page 1343 and onward.



Size: 8, 16, 25

Battery-less Absolute (Step Motor 24 VDC)

Incremental (Step Motor 24 VDC)

Incremental (Servo Motor 24 VDC)

● Reduced cycle time

● Max. pushing force: 180 N

● Positioning repeatability:  $\pm 0.05$  mm

Max. acceleration/deceleration: 5000 mm/s<sup>2</sup>

Max. speed: 400 mm/s

Compact Type LES□E/LES Series

Size\*1: 8, 16, 25 ▶ p. 641, 649

\*1 Only size 25 is available for the battery-less absolute.



Compared with the LESH, Workpiece mounting surface height: Reduced by up to 12%

40.3 mm

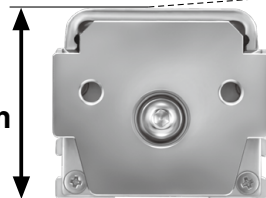

Compact type  
LES16D

46 mm

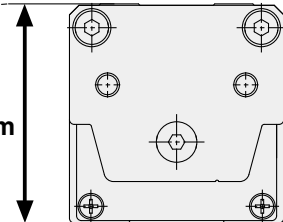

LESH16D

Basic type/R type



Symmetrical type/L type



In-line motor type/D type



High Rigidity Type LESH□E/LESH Series

Size\*1: 8, 16, 25 ▶ p. 687, 695

\*1 Only size 25 is available for the battery-less absolute.



Deflection: 0.016 mm\*2

\*2 LESH16-50 Load: 25 N

Basic type/R type

LESH□R Series



Symmetrical type/L type

LESH□L Series



In-line motor type/D type

LESH□D Series



Battery-less Absolute (Step Motor 24 VDC)

Incremental (Step Motor 24 VDC)

Incremental (Servo Motor 24 VDC)

Controllers/Drivers

▶ p. 994

▶ Step data input type

JXC51/61/  
LECA6 Series

- 64 positioning points
- Input using controller setting kit or teaching box



▶ EtherCAT/EtherNet/IP™/  
PROFINET/DeviceNet®/  
IO-Link/CC-Link

direct input type  
JXCE□/91/P1/D1/L□/M1 Series



▶ Programless type

LECP1\*1 Series

- 14 positioning points
- Control panel setting



▶ Pulse input type

LECPA\*1 Series



\*1 Excludes the battery-less absolute

Battery-less Absolute (Step Motor 24 VDC)

Compact Type **LES25E Series**

High Rigidity Type **LESH25E Series**

# Restart from the last stop position is possible after recovery of the power supply.

## Easy operation restart after recovery of the power supply

The position information is held by the encoder even when the power supply is turned off. A return to origin operation is not necessary when the power supply is recovered.

## Does not require the use of batteries. **Reduced maintenance**

Batteries are not used to store the position information. Therefore, there is no need to store spare batteries or replace dead batteries.



Compact Type  
LES25E Series

Max. speed [mm/s]	400
Positioning repeatability [mm]	±0.05
Max. work load [kg] ( ): For when mounted vertically	5 (5)
Max. pushing force [N]	180
Max. stroke [mm]	150
Motor mounting position	In-line, Parallel (Right/Left)



High Rigidity Type  
LESH25E Series

Max. speed [mm/s]	400
Positioning repeatability [mm]	±0.05
Max. work load [kg] ( ): For when mounted vertically	12 (4)
Max. pushing force [N]	180
Max. stroke [mm]	150
Motor mounting position	In-line, Parallel (Right/Left)

Incremental (Step Motor 24 VDC)

Incremental (Servo Motor 24 VDC)

**Compact Type LES Series**

**Vertical work load**

**Increased by up to 50%\*1 \*2**

\*1 By reducing the weight of moving parts  
\*2 Compared with the LESH16

Model	Vertical work load [kg]
LES16	3.0
LESH16	2.0

**Applications**

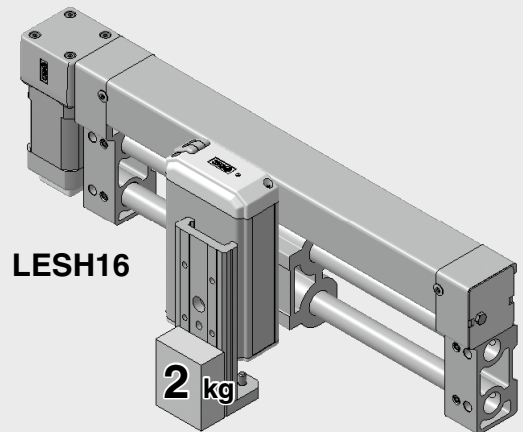
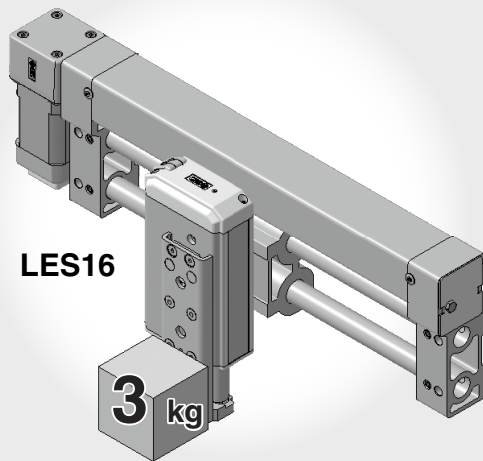

**Light weight**

**Reduced by up to 29%**

Model	Weight [kg]	Reduction amount
LES16D-100	1.20	Reduced by 0.50 kg
LESH16D-100	1.70	

- Max. pushing force: 180 N
- Positioning repeatability:  $\pm 0.05$  mm
- 2 types of motors selectable: Incremental (Step motor 24 VDC), Incremental (Servo motor 24 VDC)
- Can reduce cycle time  
Max. acceleration/deceleration: 5000 mm/s<sup>2</sup>  
Max. speed: 400 mm/s

Basic type/R type

**LES□R Series**



Symmetrical type/L type

**LES□L Series**



In-line motor type/D type

**LES□D Series**



# Slide Tables *LES/LESH Series*

Incremental (Step Motor 24 VDC)    Incremental (Servo Motor 24 VDC)

## High Rigidity Type *LESH Series*

**High rigidity** Deflection: **0.016 mm**\*1 \*1 LESH16-50 Load: 25 N

**Integration of the guide rail and the table**  
**Uses a circulating linear guide.**

**Compact, Space-saving**  
 For LESH8 R/L, 50 mm stroke

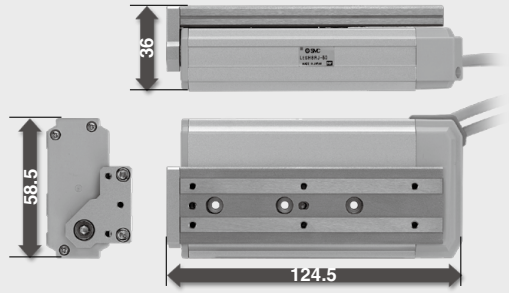
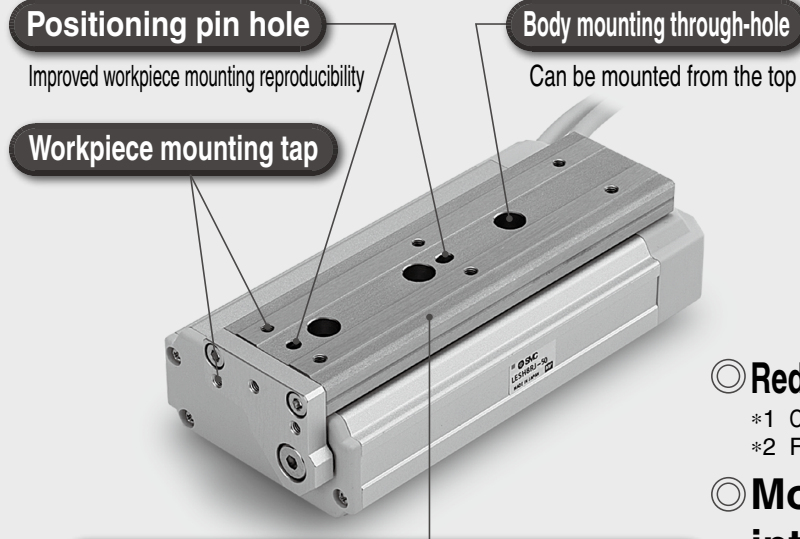

**Reduced by 61% in volume**\*1 \*2  
 \*1 Compared with the LESH16-50/LXSH-50  
 \*2 For R/L type

**Motor integrated into the body** (Built-in motor)

**Integration of the guide rail and the table**

**Select from 2 types of motors.**

- **Incremental (Step motor 24 VDC)**  
Ideal for the low-speed transfer of heavy loads and pushing operations
- **Incremental (Servo motor 24 VDC)**  
Stable at high speeds  
Silent operation

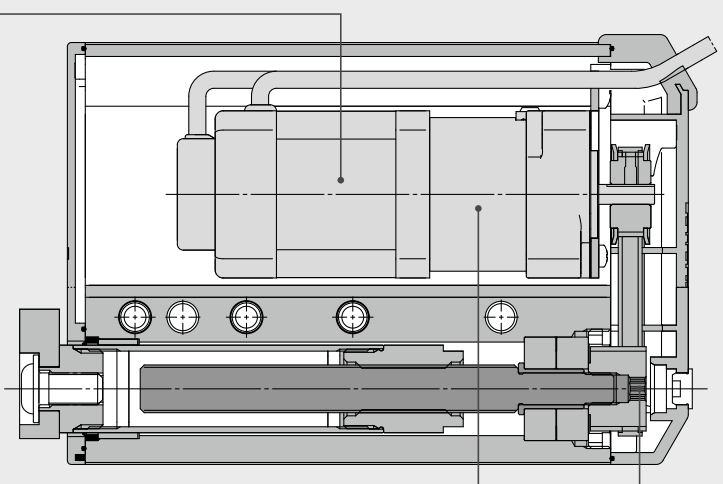
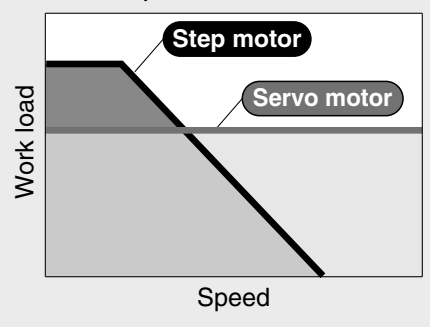

**Non-magnetizing lock mechanism (Option)**  
 Prevents workpieces from dropping (Holding)

**Manual override screw**  
 Adjustment operation is possible when the power is OFF.

## Application Examples

**For positioning of pallets on a conveyor**

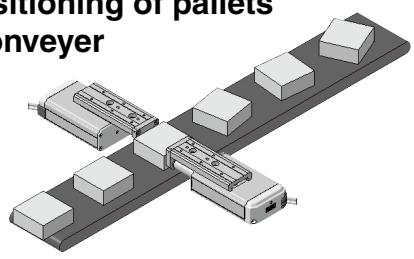

**For Z motion for pick and place operations**

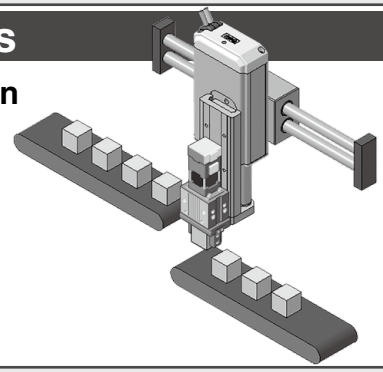



## Symmetrical Type/L Type

The locations of the table and cable are opposite those of the basic type (R type), expanding design applications.

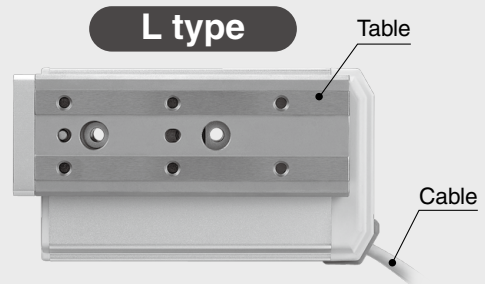
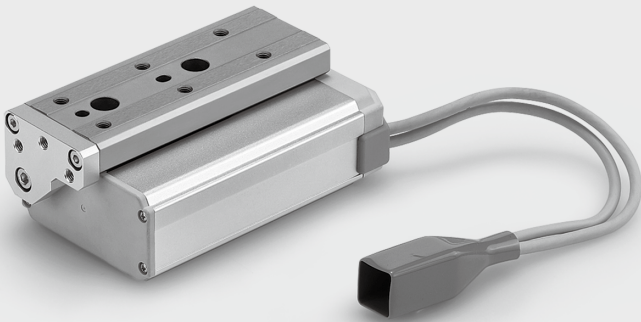

### Installation example

When two tables are installed side by side, they will not interfere with each other, allowing for space saving.

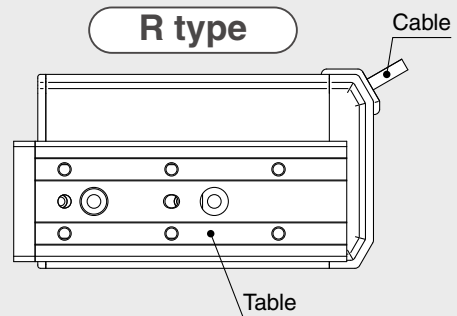
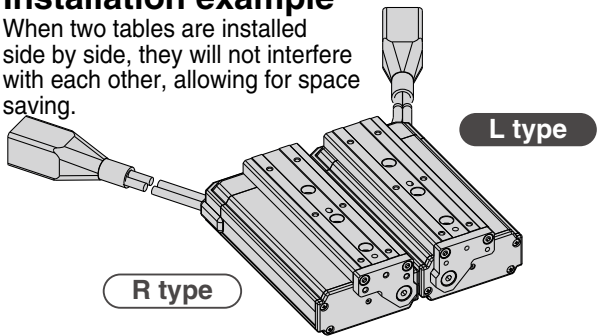

## In-line Motor Type/D Type

Width dimension shortened by up to 45%



**D type**

**R type**

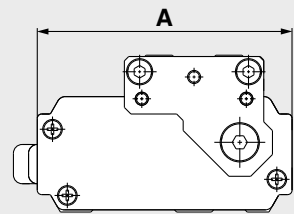
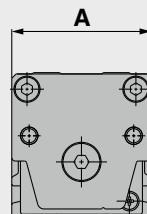

**A Dimension**

[mm]

Size	D type	R/L type
8	32	58.5
16	45	72.5
25	61	106

## How to Mount

**Through-hole mounting**

(R/L/D type)

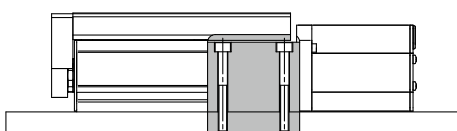

**Side holder mounting**

(D type)

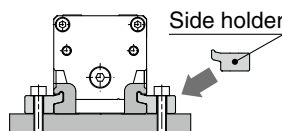

**Body tapped mounting**

(R/L/D type)

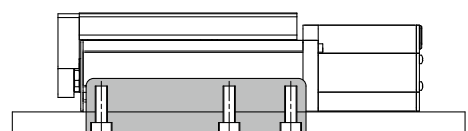

# CONTENTS

## Slide Table/Compact Type *LES Series*

### Battery-less Absolute (Step Motor 24 VDC)



Model Selection .....	p. 641
How to Order .....	p. 659
Specifications.....	p. 661
Weight.....	p. 661
Construction .....	p. 662
Dimensions .....	p. 664

### Incremental (Step Motor 24 VDC)



### Incremental (Servo Motor 24 VDC)

Model Selection .....	p. 649, 655
How to Order .....	p. 669
Specifications.....	p. 672
Construction .....	p. 674
Dimensions .....	p. 676

## Slide Table/High Rigidity Type *LESH Series*

### Battery-less Absolute (Step Motor 24 VDC)

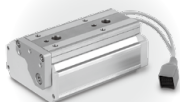

Model Selection .....	p. 687
How to Order .....	p. 705
Specifications.....	p. 707
Weight.....	p. 707
Construction .....	p. 708
Dimensions .....	p. 710

### Incremental (Step Motor 24 VDC)



### Incremental (Servo Motor 24 VDC)

Model Selection .....	p. 695, 701
How to Order .....	p. 715
Specifications.....	p. 718
Construction .....	p. 720
Dimensions .....	p. 722

Specific Product Precautions .....	p. 732
------------------------------------	--------

## Incremental (Step Motor 24 VDC)/ Incremental (Servo Motor 24 VDC) Controllers

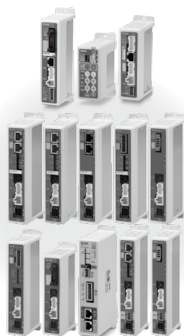

Step Data Input Type/ <i>JXC51/61 Series</i> .....	p. 1017
Step Data Input Type/ <i>LECA6 Series</i> .....	p. 1031
EtherCAT/EtherNet/IP™/PROFINET/DeviceNet®/IO-Link Direct Input Type/ <i>JXCE□/91/P1/D1/L□/M1 Series</i> .....	p. 1063
Gateway Unit/ <i>LEC-G Series</i> .....	p. 1038
Programless Controller/ <i>LECP1 Series</i> .....	p. 1042
Step Motor Driver/ <i>LECPA Series</i> .....	p. 1057
Actuator Cable .....	p. 1091
Communication Cable for Controller Setting/ <i>LEC-W2A-□</i> .....	p. 1094
Teaching Box/ <i>LEC-T1</i> .....	p. 1095

## 3-Axis Step Motor Controller



EtherNet/IP™ Type/ <i>JXC92 Series</i> .....	p. 1079
----------------------------------------------	---------

## 4-Axis Step Motor (Servo/24 VDC) Controller



Parallel I/O Type/ <i>JXC73/83 Series</i> .....	p. 1081
EtherNet/IP™ Type/ <i>JXC93 Series</i> .....	p. 1081

# Slide Tables

## Compact Type *LES Series*

Battery-less Absolute (Step Motor 24 VDC)

p. 659

Incremental (Step Motor 24 VDC)

Incremental (Servo Motor 24 VDC)

p. 669

Symmetrical type (L type)

Basic type (R type)

In-line motor type (D type)

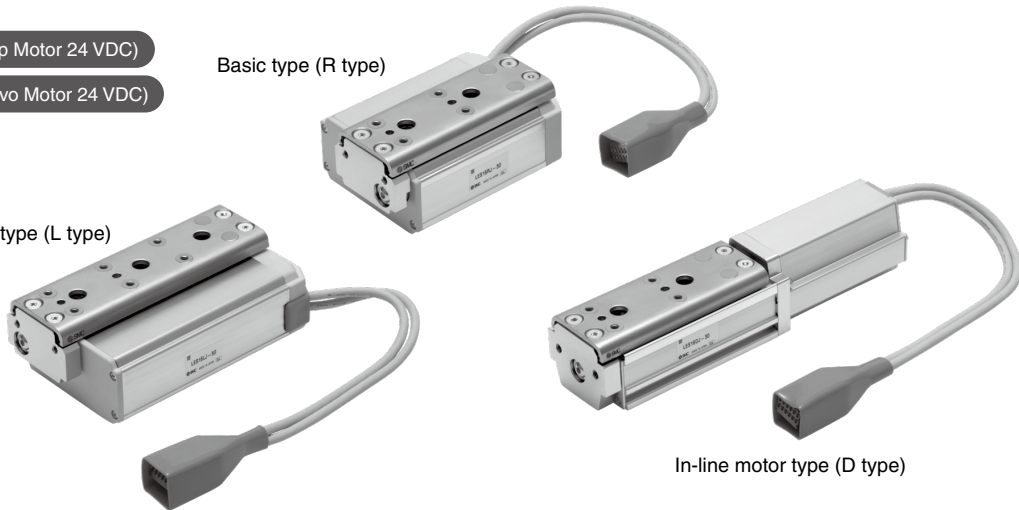

## High Rigidity Type *LESH Series*

Battery-less Absolute (Step Motor 24 VDC)

p. 705

Incremental (Step Motor 24 VDC)

Incremental (Servo Motor 24 VDC)

p. 715

Symmetrical type (L type)

Basic type (R type)

In-line motor type (D type)

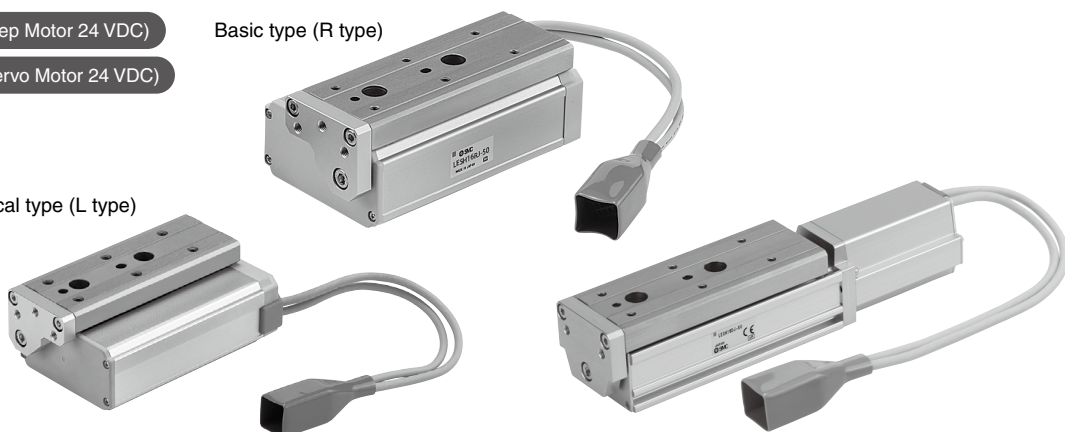

Controllers/Drivers p. 994

# Model Selection 1



LES□E Series ▶ p. 659

## Selection Procedure

For the high rigidity type LESH series, refer to page 687.



## Selection Example

**Step 1 Check the work load-speed.** <Speed-Work load graph> (page 642)  
 Select a model based on the workpiece mass and speed while referencing the speed-work load graph.  
 Selection example) The LES25□EJ-50 can be temporarily selected as a possible candidate based on the graph shown on the right side.

**Step 2 Check the cycle time.**  
 It is possible to find an approximate cycle time by using method 1, but if a more detailed cycle time is required, use method 2.

### Method 1: Check the cycle time graph. (page 642)

### Method 2: Calculation <Speed-Work load graph> (page 642)

Calculate the cycle time using the following calculation method. Calculation example)  
 T1 to T4 can be calculated as follows.

#### Cycle time:

T can be found from the following equation.

$$T = T1 + T2 + T3 + T4 \text{ [s]}$$

- T1: Acceleration time and T3: Deceleration time can be found by the following equation.

$$T1 = V/a1 \text{ [s]} \quad T3 = V/a2 \text{ [s]}$$

- T2: Constant speed time can be found from the following equation.

$$T2 = \frac{L - 0.5 \cdot V \cdot (T1 + T3)}{V} \text{ [s]}$$

- T4: Settling time varies depending on the conditions such as motor types, load, and in position of the step data. Therefore, calculate the settling time while referencing the following value.

$$T4 = 0.15 \text{ [s]}$$

$$T1 = V/a1 = 200/5000 = 0.04 \text{ [s]}$$

$$T3 = V/a2 = 200/5000 = 0.04 \text{ [s]}$$

$$T2 = \frac{L - 0.5 \cdot V \cdot (T1 + T3)}{V} = \frac{50 - 0.5 \cdot 200 \cdot (0.04 + 0.04)}{200}$$

$$= 0.21 \text{ [s]}$$

$$T4 = 0.15 \text{ [s]}$$

The cycle time can be found as follows.

$$T = T1 + T2 + T3 + T4 = 0.04 + 0.21 + 0.04 + 0.15 = 0.44 \text{ [s]}$$

## Operating conditions

- Workpiece mass: 2 [kg]
- Workpiece mounting condition:
- Speed: 200 [mm/s]
- Mounting orientation: Vertical
- Stroke: 50 [mm]
- Acceleration/Deceleration: 5000 [mm/s<sup>2</sup>]
- Cycle time: 0.5 s

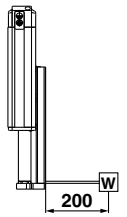

## LES25□E□/Battery-less Absolute Vertical

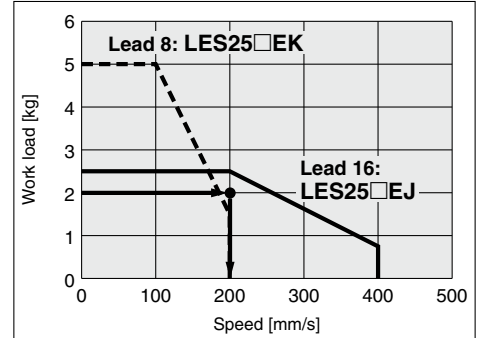

<Speed-Work load graph>

## LES25/Battery-less Absolute Pitching

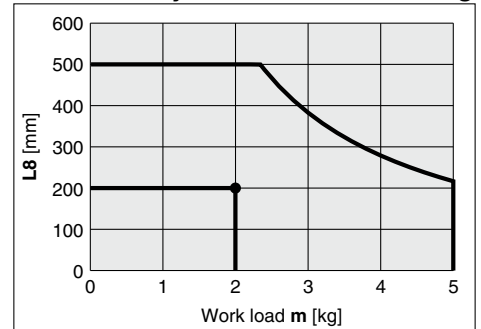

<Dynamic allowable moment>

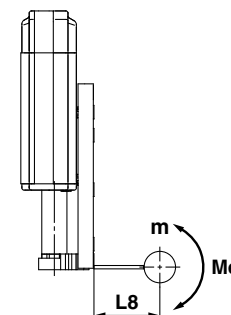

**Step 3 Check the allowable moment.** <Static allowable moment> (page 642)  
 <Dynamic allowable moment> (page 643)

Confirm the moment that applies to the actuator is within the allowable range for both static and dynamic conditions.

Based on the above calculation result, the LES25□EJ-50 should be selected.



## Speed-Work Load Graph (Guide)

### Battery-less Absolute (Step Motor 24 VDC)

\* The following graphs show the values when the moving force is 100%.

#### LES25□E□

##### Horizontal

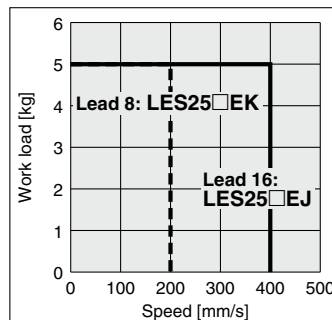

##### Vertical

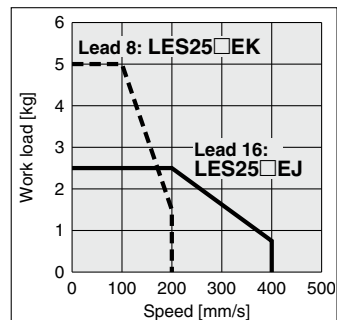

## Cycle Time Graph (Guide)

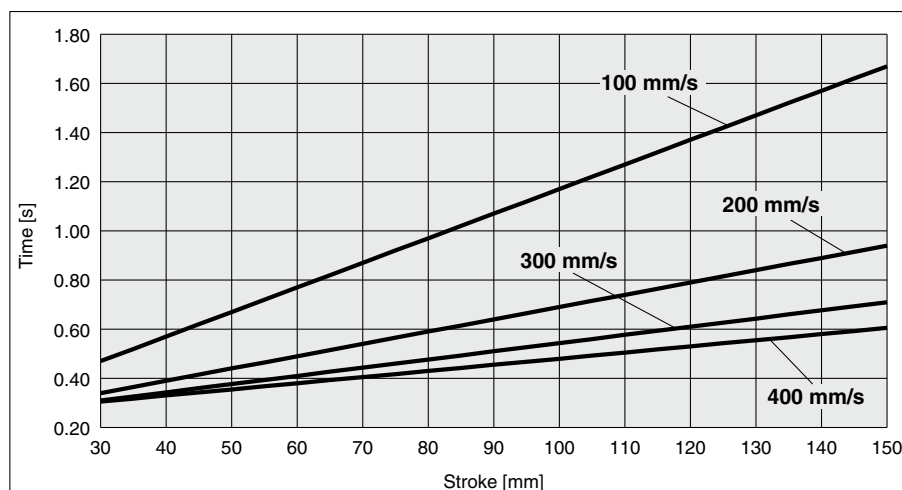

### Operating Conditions

Acceleration/Deceleration: 5000 mm/s<sup>2</sup>

In position: 0.5 mm

## Static Allowable Moment

Model		LES25
Pitching	[N·m]	14.1
Yawing	[N·m]	14.1
Rolling	[N·m]	4.8

# LES Series

Battery-less Absolute (Step Motor 24 VDC)

\* These graphs show the amount of allowable overhang (guide unit) when the center of gravity of the workpiece overhangs in one direction. When selecting the overhang, refer to the "Calculation of Guide Load Factor" or the Electric Actuator Model Selection Software for confirmation: <https://www.smcworld.com>

## Dynamic Allowable Moment

Acceleration/Deceleration — 5000 mm/s<sup>2</sup>

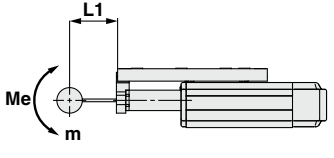
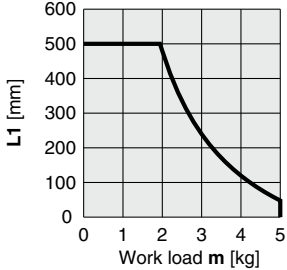
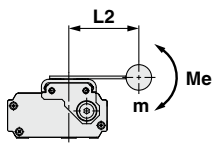
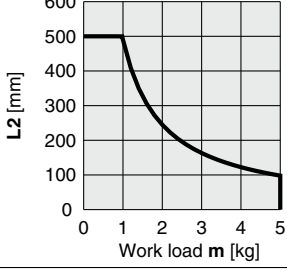
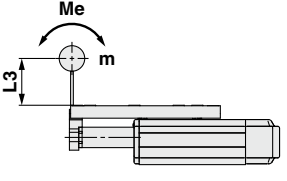
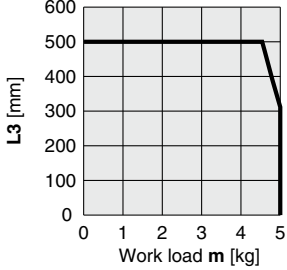
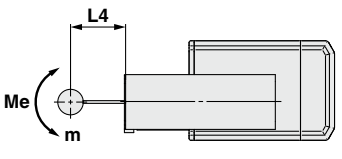
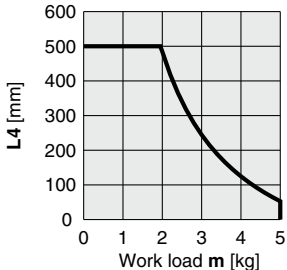
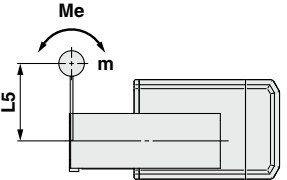
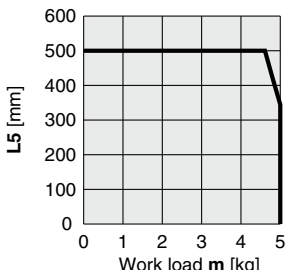
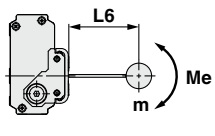
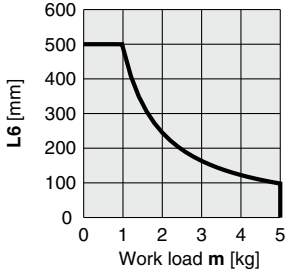
Orientation		Load overhanging direction	Model
		<b>m</b> : Work load [kg] <b>Me</b> : Allowable moment [N·m] <b>L</b> : Overhang to the work load center of gravity [mm]	<b>LES25</b>
Horizontal/Bottom	X		
	Y		
	Z		
Wall	X		
	Y		
	Z		

\* These graphs show the amount of allowable overhang (guide unit) when the center of gravity of the workpiece overhangs in one direction. When selecting the overhang, refer to the "Calculation of Guide Load Factor" or the Electric Actuator Model Selection Software for confirmation: <https://www.smcworld.com>

## Dynamic Allowable Moment

Acceleration/Deceleration — 5000 mm/s<sup>2</sup>

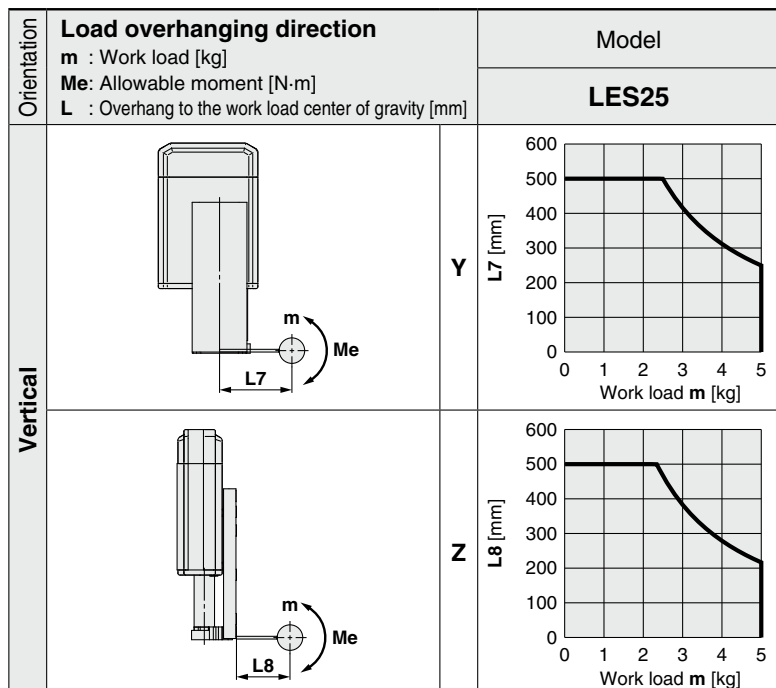

## Calculation of Guide Load Factor

- Decide operating conditions.

Model: LES

Size: 25

Mounting orientation: Horizontal/Bottom/Wall/Vertical

Acceleration [mm/s<sup>2</sup>]: a

Work load [kg]: m

Work load center position [mm]: Xc/Yc/Zc

- Select the target graph while referencing the model, size, and mounting orientation.

- Based on the acceleration and work load, find the overhang [mm]: Lx/Ly/Lz from the graph.

- Calculate the load factor for each direction.

$$\alpha x = Xc/Lx, \alpha y = Yc/Ly, \alpha z = Zc/Lz$$

- Confirm the total of  $\alpha x$ ,  $\alpha y$ , and  $\alpha z$  is 1 or less.

$$\alpha x + \alpha y + \alpha z \leq 1$$

When 1 is exceeded, please consider a reduction of acceleration and work load, or a change of the work load center position and series.

### Mounting orientation

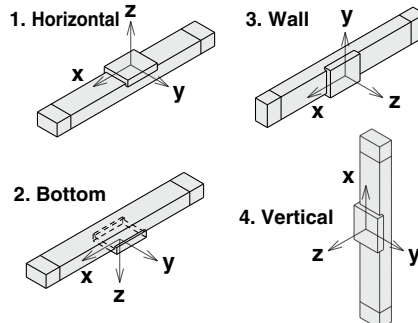

### Example

- Operating conditions

Model: LES

Size: 25

Mounting orientation: Horizontal

Acceleration [mm/s<sup>2</sup>]: 5000

Work load [kg]: 2.0

Work load center position [mm]: Xc = 100, Yc = 50, Zc = 100

- Select three graphs from the top on page 643.

- Lx = 500 mm, Ly = 240 mm, Lz = 500 mm

- The load factor for each direction can be found as follows.

$$\alpha x = 100/500 = 0.20$$

$$\alpha y = 50/240 = 0.21$$

$$\alpha z = 100/500 = 0.20$$

- $\alpha x + \alpha y + \alpha z = 0.61 \leq 1$

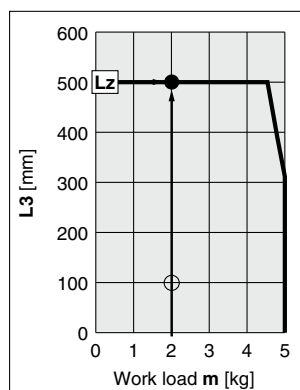
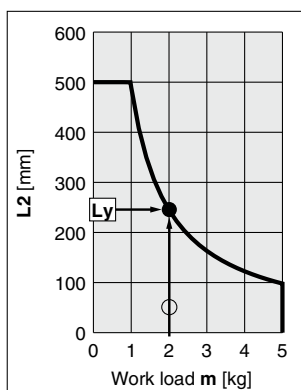
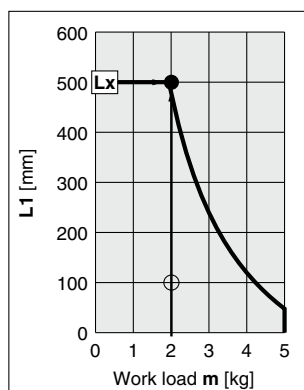

# Model Selection 2



## Selection Procedure

For the high rigidity type LESH series, refer to page 691.



## Selection Example

### Operating conditions

- Pushing force: 90 [N]
- Workpiece mass: 1 [kg]
- Speed: 100 [mm/s]
- Stroke: 100 [mm]
- Mounting orientation: Vertical upward
- Pushing time + Operation (A): 1.5 s
- Full cycle time (B): 6 s

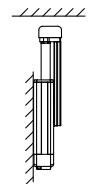

### Step 1 Check the required force.

Calculate the approximate required force for a pushing operation.

- Selection example) • Pushing force: 90 [N]  
• Workpiece mass: 1 [kg]

The approximate required force can be found to be  $90 + 10 = 100$  [N].

Select a model based on the approximate required force while referencing the specifications (page 661).

Selection example) Based on the specifications,

- Approximate required force: 100 [N]
- Speed: 100 [mm/s]

The LES25□E can be temporarily selected as a possible candidate.

Then, calculate the required force for a pushing operation.

If the mounting position is vertical upward, add the actuator table weight.

Selection example) Based on the table weight,

- LES25□E table weight: 0.5 [kg]

The required force can be found to be  $100 + 5 = 105$  [N].

### Step 2 Check the pushing force set value.

<Pushing force set value–Force graph> (page 646)

Select a model based on the required force while referencing the pushing force set value–force graph, and confirm the pushing force set value.

Selection example) Based on the graph shown on the right side,

- Required force: 105 [N]

The LES25□EK can be temporarily selected as a possible candidate.

This pushing force set value is 40 [%].

### Step 3 Check the duty ratio.

Confirm the allowable duty ratio based on the pushing force set value while referencing the allowable duty ratio.

Selection example) Based on the allowable duty ratio,

- Pushing force set value: 40 [%]

The allowable duty ratio can be found to be 30 [%].

Calculate the duty ratio for the operating conditions, and confirm it does not exceed the allowable duty ratio.

Selection example) • Pushing time + Operation (A): 1.5 s

- Full cycle time (B): 6 s

The duty ratio can be found to be  $1.5/6 \times 100 = 25$  [%], and this is within the allowable range.

### Table Weight

[kg]

Model	Stroke [mm]					
	30	50	75	100	125	150
LES25	0.25	0.30	0.36	0.50	0.55	0.59

\* If the mounting position is vertical upward, add the table weight.

### LES25□E□/Battery-less Absolute

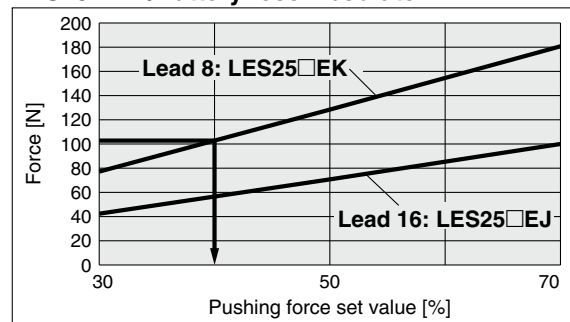

<Pushing force set value–Force graph>

### Allowable Duty Ratio

#### Battery-less Absolute

Pushing force set value [%]	Duty ratio [%]	Continuous pushing time [min]
30	—	—
50 or less	30 or less	5 or less
70 or less	20 or less	3 or less

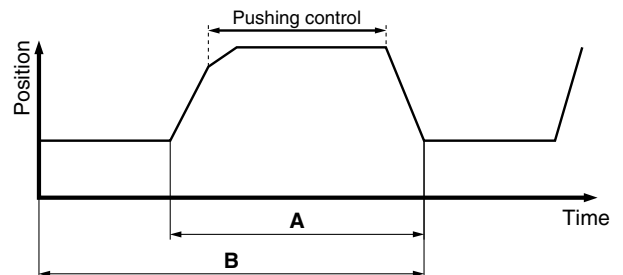

Based on the above calculation result, the LES25□EK-100 should be selected.

For allowable moment, the selection procedure is the same as that for the positioning control.



**Pushing Force Set Value–Force Graph**

Battery-less Absolute (Step Motor 24 VDC)

LES25□E□

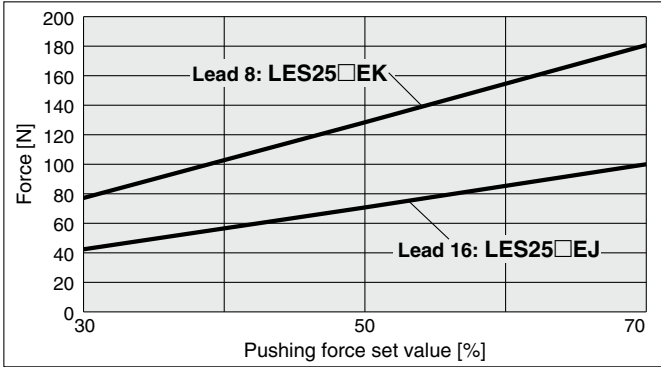

**Table Accuracy**

\* These values are initial guideline values.

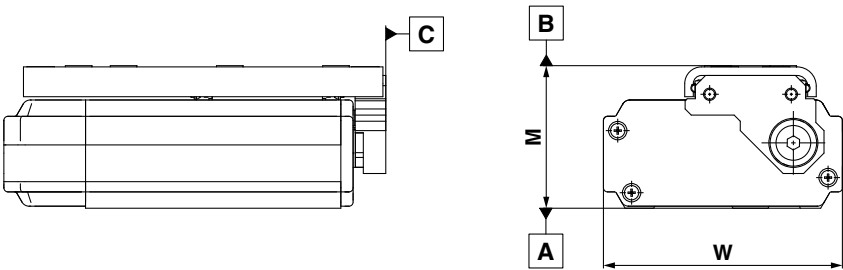

Model	LES25
B side parallelism to A side	0.4 mm
B side traveling parallelism to A side	Refer to Graph 1.
C side perpendicularity to A side	0.2 mm
M dimension tolerance	±0.3 mm
W dimension tolerance	±0.2 mm

**Graph 1 B side traveling parallelism to A side**

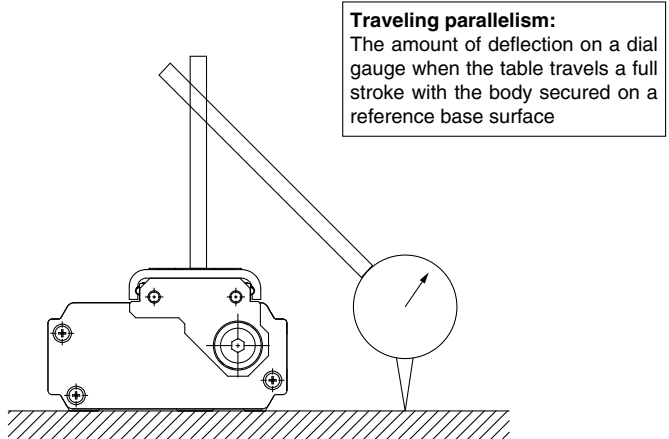
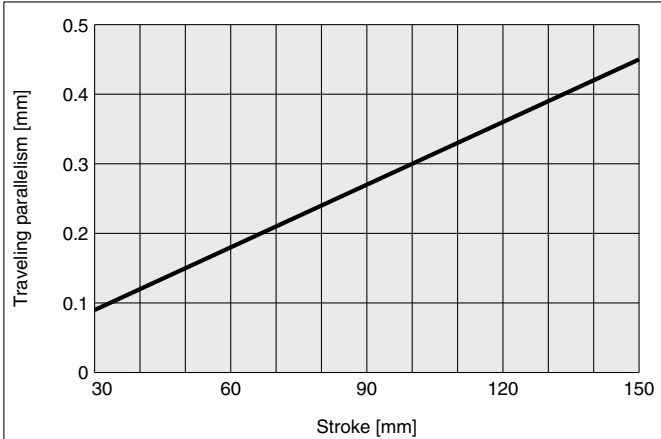

## Table Deflection (Reference Value)

\* These values are initial guideline values.

### Pitching moment

Table displacement due to pitch moment load  
Table displacement when loads are applied to the section marked with the arrow with the slide table stuck out.

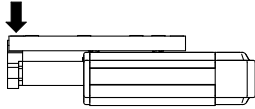

### LES25

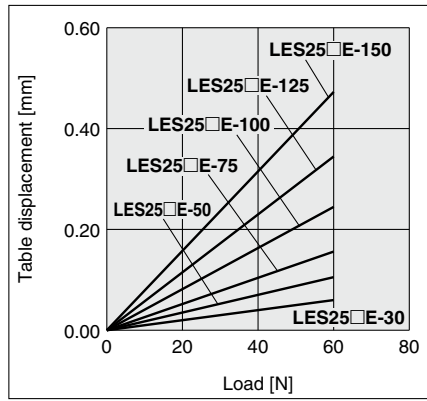

### Yawing moment

Table displacement due to yaw moment load  
Table displacement when loads are applied to the section marked with the arrow with the slide table stuck out.

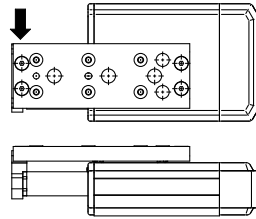

### LES25

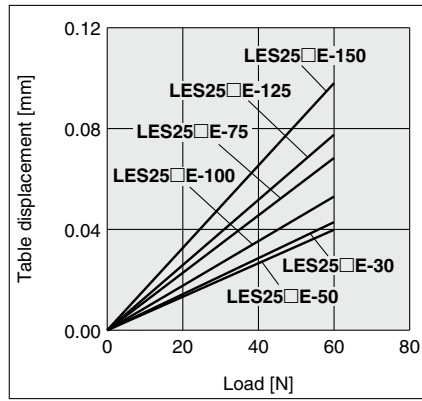

### Rolling moment

Table displacement due to roll moment load  
Table displacement of section A when loads are applied to the section F with the slide table retracted.

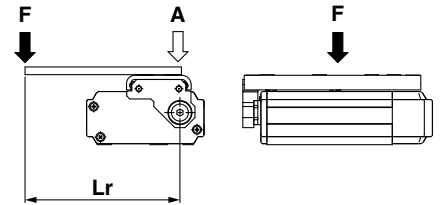

### LES25

Lr = 100 mm

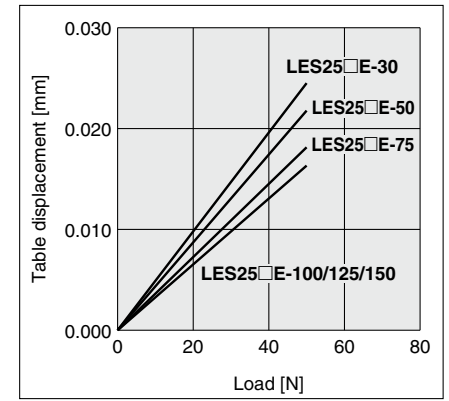



Slide Table/Compact Type

LES Series

# Model Selection 1



LES Series ▶ p. 669

## Selection Procedure

For the high rigidity type LESH series, refer to page 695.



## Selection Example

**Step 1 Check the work load-speed. <Speed-Work load graph>** (Page 650)  
 Select a model based on the workpiece mass and speed while referencing the speed-work load graph.  
 Selection example) The LES16□J-50 can be temporarily selected as a possible candidate based on the graph shown on the right side.

**Step 2 Check the cycle time.**  
 It is possible to find an approximate cycle time by using method 1, but if a more detailed cycle time is required, use method 2.

**Method 1: Check the cycle time graph. (Page 651)**

**Method 2: Calculation <Speed-Work load graph>** (Page 650)

Calculate the cycle time using the following calculation method. Calculation example)  
 T1 to T4 can be calculated as follows.

**Cycle time:**

T can be found from the following equation.

$$T = T1 + T2 + T3 + T4 \text{ [s]}$$

- T1: Acceleration time and T3: Deceleration time can be found by the following equation.

$$T1 = V/a1 \text{ [s]} \quad T3 = V/a2 \text{ [s]}$$

- T2: Constant speed time can be found from the following equation.

$$T2 = \frac{L - 0.5 \cdot V \cdot (T1 + T3)}{V} \text{ [s]}$$

- T4: Settling time varies depending on the conditions such as motor types, load, and in position of the step data. Therefore, calculate the settling time while referencing the following value.

$$T4 = 0.15 \text{ [s]}$$

$$T1 = V/a1 = 220/5000 = 0.04 \text{ [s]}$$

$$T3 = V/a2 = 220/5000 = 0.04 \text{ [s]}$$

$$T2 = \frac{L - 0.5 \cdot V \cdot (T1 + T3)}{V} = \frac{50 - 0.5 \cdot 220 \cdot (0.04 + 0.04)}{220}$$

$$= 0.19 \text{ [s]}$$

$$T4 = 0.15 \text{ [s]}$$

The cycle time can be found as follows.

$$T = T1 + T2 + T3 + T4 = 0.04 + 0.19 + 0.04 + 0.15 = 0.42 \text{ [s]}$$

## Operating conditions

- Workpiece mass: 1 [kg]
- Workpiece mounting condition:
- Speed: 220 [mm/s]
- Mounting orientation: Vertical
- Stroke: 50 [mm]
- Acceleration/Deceleration: 5000 [mm/s<sup>2</sup>]
- Cycle time: 0.5 s

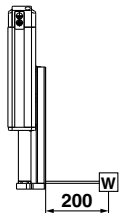

## LES16□/Step Motor Vertical

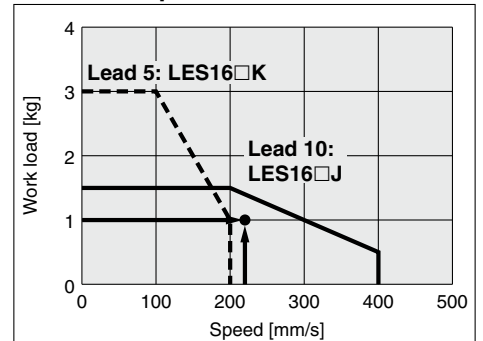

<Speed-Work load graph>

## LES16□/Step Motor

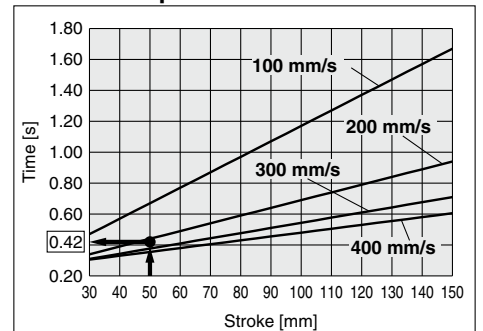

<Cycle time>

## LES16/Pitching

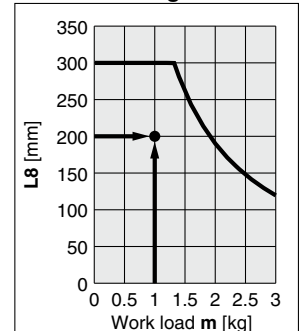

<Dynamic allowable moment>

**Step 3 Check the allowable moment. <Static allowable moment>** (Page 651)  
 <Dynamic allowable moment> (Pages 652, 653)

Confirm the moment that applies to the actuator is within the allowable range for both static and dynamic conditions.

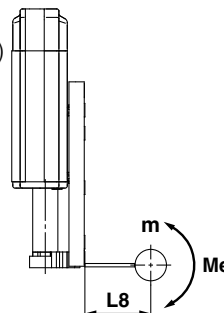

Based on the above calculation result, the LES16□J-50 should be selected.



## Speed-Work Load Graph (Guide)

### Step Motor (Servo/24 VDC)

\* The following graphs show the values when moving force is 100%.

#### LES8□

##### Horizontal

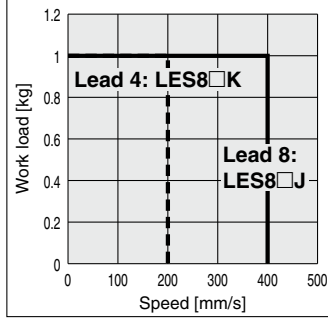

##### Vertical

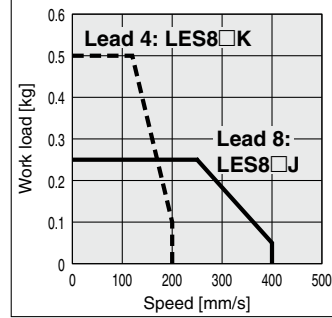

### Servo Motor (24 VDC)

\* The following graphs show the values when moving force is 250%.

#### LES8□A

##### Horizontal

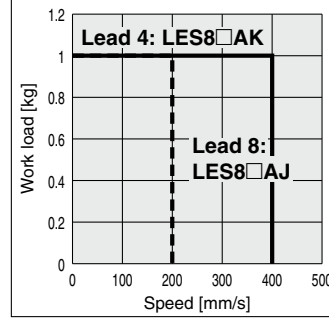

##### Vertical

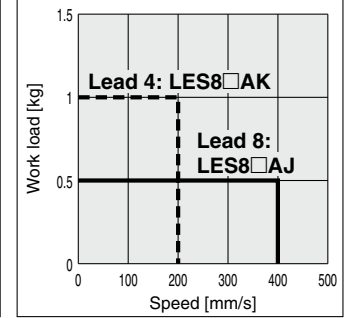

#### LES16□

##### Horizontal

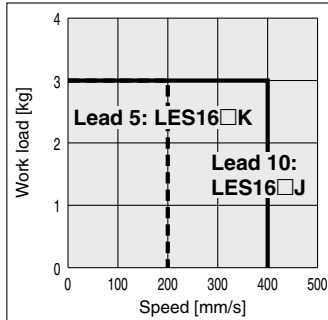

##### Vertical

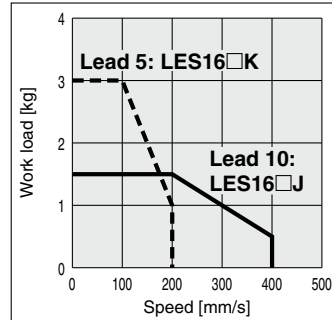

#### LES16□A

##### Horizontal

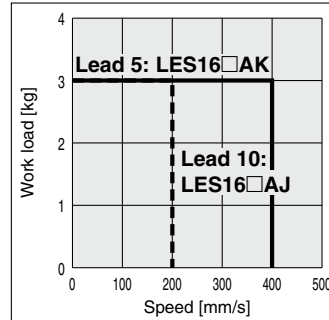

##### Vertical

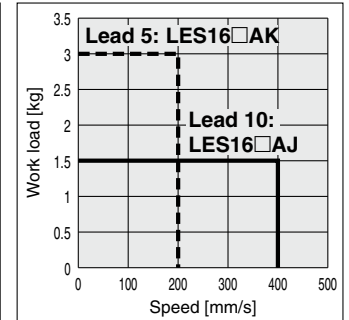

#### LES25□

##### Horizontal

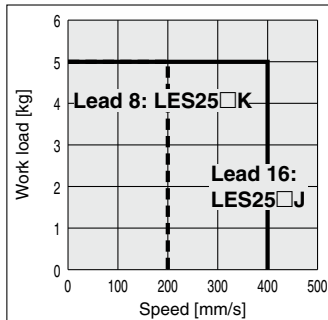

##### Vertical

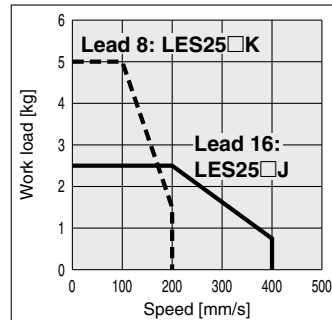

#### LES25□A

##### Horizontal

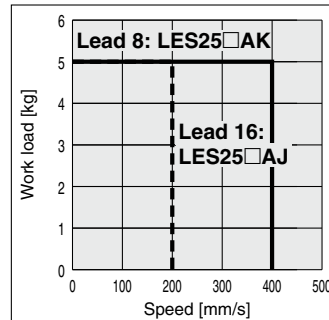

##### Vertical

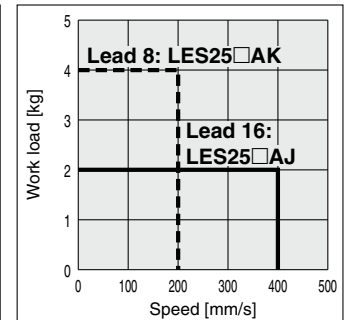

# LES Series

Incremental (Step Motor 24 VDC)

Incremental (Servo Motor 24 VDC)

## Cycle Time Graph (Guide)

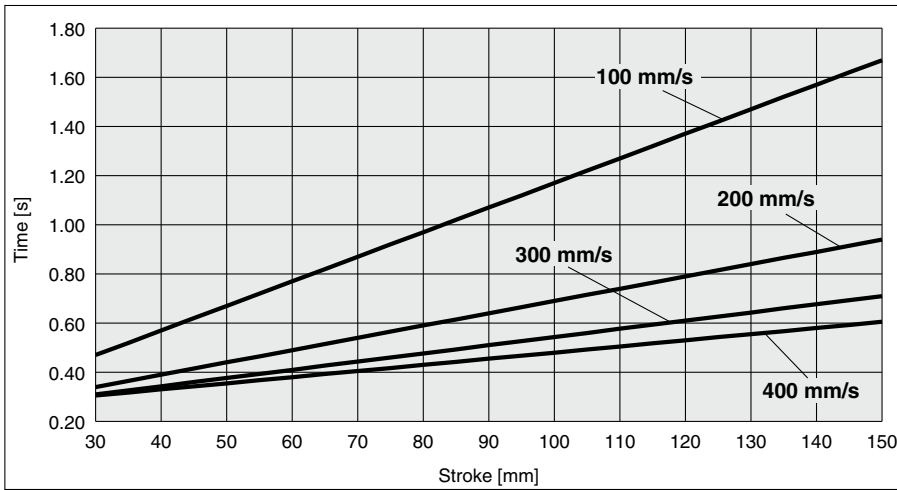

### Operating Conditions

Acceleration/Deceleration: 5000 mm/s<sup>2</sup>

In position: 0.5 mm

## Static Allowable Moment

Model		LES8	LES16	LES25
Pitching	[N·m]	2	4.8	14.1
Yawing	[N·m]	2	4.8	14.1
Rolling	[N·m]	0.8	1.8	4.8

\* These graphs show the amount of allowable overhang (guide unit) when the center of gravity of the workpiece overhangs in one direction. When selecting the overhang, refer to the "Calculation of Guide Load Factor" or the Electric Actuator Model Selection Software for confirmation: <https://www.smcworld.com>

## Dynamic Allowable Moment

Acceleration/Deceleration — 5000 mm/s<sup>2</sup>

Orientation		Load overhanging direction	Model		
		<b>m</b> : Work load [kg] <b>Me</b> : Allowable moment [N·m] <b>L</b> : Overhang to the work load center of gravity [mm]	<b>LES8</b>	<b>LES16</b>	<b>LES25</b>
Horizontal/Bottom	X				
	Y				
	Z				
Wall	X				
	Y				
	Z				

\* These graphs show the amount of allowable overhang (guide unit) when the center of gravity of the workpiece overhangs in one direction. When selecting the overhang, refer to the "Calculation of Guide Load Factor" or the Electric Actuator Model Selection Software for confirmation: <https://www.smcworld.com>

## Dynamic Allowable Moment

Acceleration/Deceleration — 5000 mm/s<sup>2</sup>

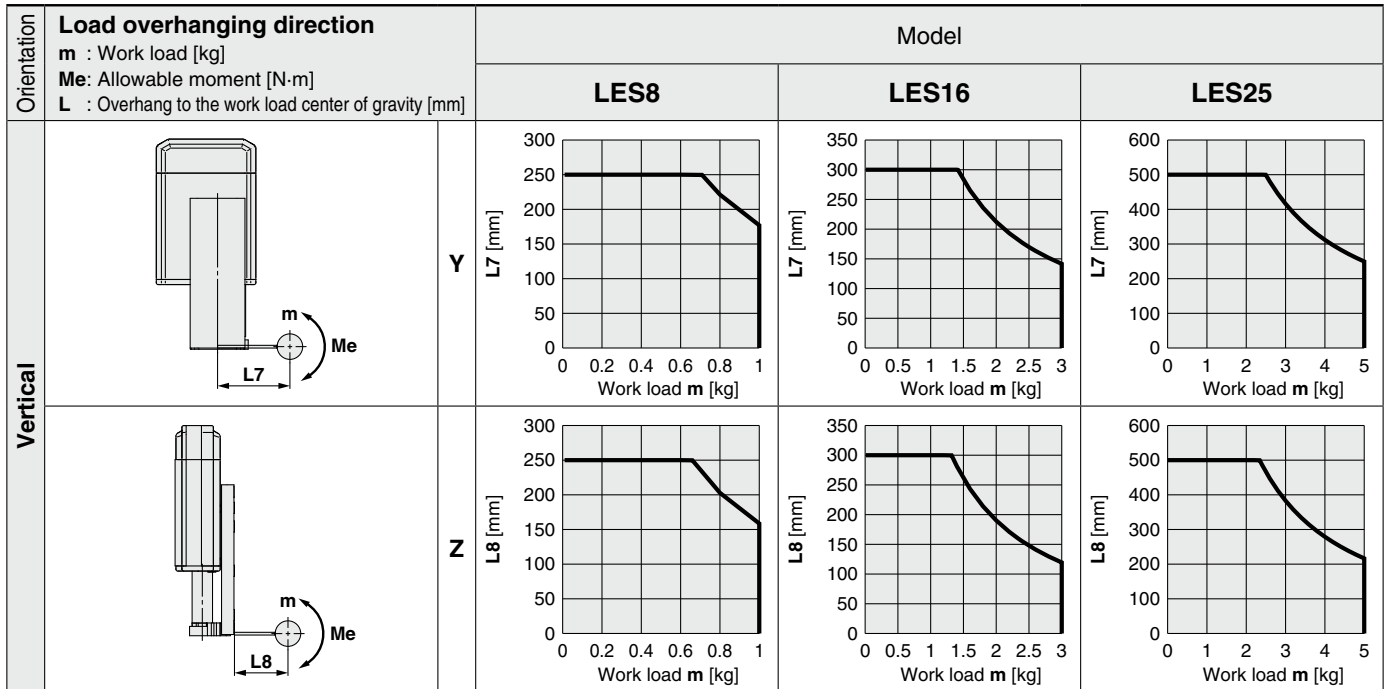

## Calculation of Guide Load Factor

- Decide operating conditions.

Model: LES

Size: 8/16/25

Mounting orientation: Horizontal/Bottom/Wall/Vertical

Acceleration [mm/s<sup>2</sup>]: a

Work load [kg]: m

Work load center position [mm]: Xc/Yc/Zc

- Select the target graph while referencing the model, size, and mounting orientation.

- Based on the acceleration and work load, find the overhang [mm]: Lx/Ly/Lz from the graph.

- Calculate the load factor for each direction.

$$\alpha_x = X_c/L_x, \alpha_y = Y_c/L_y, \alpha_z = Z_c/L_z$$

- Confirm the total of  $\alpha_x$ ,  $\alpha_y$ , and  $\alpha_z$  is 1 or less.

$$\alpha_x + \alpha_y + \alpha_z \leq 1$$

When 1 is exceeded, please consider a reduction of acceleration and work load, or a change of the work load center position and series.

### Mounting orientation

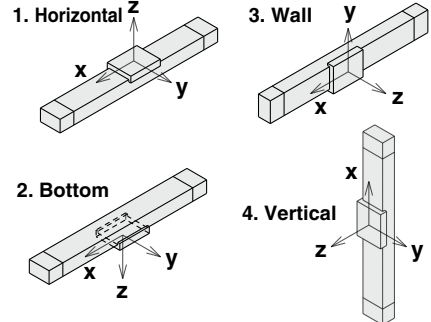

### Example

- Operating conditions

Model: LES

Size: 8

Mounting orientation: Horizontal

Acceleration [mm/s<sup>2</sup>]: 5000

Work load [kg]: 0.6

Work load center position [mm]: Xc = 50, Yc = 30, Zc = 60

- Select three graphs from the top of the left side first row on page 652.

- Lx = 220 mm, Ly = 135 mm, Lz = 250 mm

- The load factor for each direction can be found as follows.

$$\alpha_x = 50/220 = 0.23$$

$$\alpha_y = 30/135 = 0.22$$

$$\alpha_z = 60/250 = 0.24$$

- $\alpha_x + \alpha_y + \alpha_z = 0.69 \leq 1$

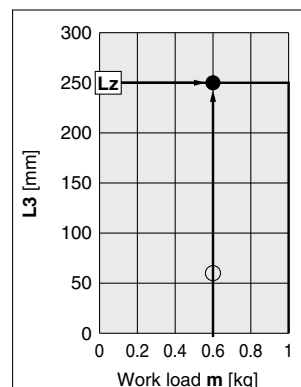
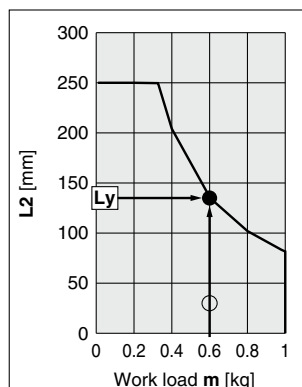
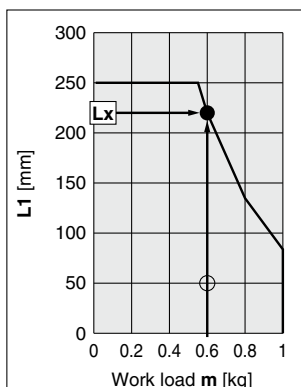



## Slide Table/Compact Type

## LES Series

## Model Selection 2



LES Series ▶ p. 669

## Selection Procedure

For the high rigidity type LESH series, refer to page 701.

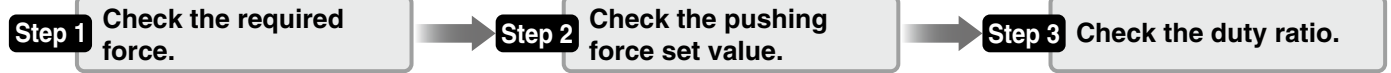

## Selection Example

## Operating conditions

- Pushing force: 90 [N]
- Workpiece mass: 1 [kg]
- Speed: 100 [mm/s]
- Stroke: 100 [mm]
- Mounting orientation: Vertical upward
- Pushing time + Operation (A): 1.5 s
- Full cycle time (B): 6 s

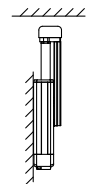
**Step 1** Check the required force.

Calculate the approximate required force for a pushing operation.

Selection example) • Pushing force: 90 [N]  
 • Workpiece mass: 1 [kg]  
 The approximate required force can be found to be  $90 + 10 = 100$  [N].

Select a model based on the approximate required force while referencing the specifications (Pages 672, 673).

Selection example) Based on the specifications,  
 • Approximate required force: 100 [N]  
 • Speed: 100 [mm/s]  
 The LES25□ can be temporarily selected as a possible candidate.

Then, calculate the required force for a pushing operation. If the mounting position is vertical upward, add the actuator table weight.

Selection example) Based on the table weight,  
 • LES25□ table weight: 0.5 [kg]  
 The required force can be found to be  $100 + 5 = 105$  [N].

**Step 2** Check the pushing force set value.

&lt;Pushing force set value–Force graph&gt; (Page 656)

Select a model based on the required force while referencing the pushing force set value–force graph, and confirm the pushing force set value.

Selection example) Based on the graph shown on the right side,  
 • Required force: 105 [N]  
 The LES25□K can be temporarily selected as a possible candidate.  
 This pushing force set value is 40 [%].

**Step 3** Check the duty ratio.

Confirm the allowable duty ratio based on the pushing force set value while referencing the allowable duty ratio.

Selection example) Based on the allowable duty ratio,  
 • Pushing force set value: 40 [%]  
 The allowable duty ratio can be found to be 30 [%].

Calculate the duty ratio for the operating conditions, and confirm it does not exceed the allowable duty ratio.

Selection example) • Pushing time + Operation (A): 1.5 s  
 • Full cycle time (B): 6 s  
 The duty ratio can be found to be  $1.5/6 \times 100 = 25$  [%], and this is within the allowable range.

Based on the above calculation result, the LES25□K-100 should be selected. For allowable moment, the selection procedure is the same as that for the positioning control.

655

## Table Weight

[kg]

Model	Stroke [mm]					
	30	50	75	100	125	150
LES8	0.06	0.08	0.10	—	—	—
LES16	0.10	0.13	0.18	0.20	—	—
LES25	0.25	0.30	0.36	0.50	0.55	0.59

\* If the mounting position is vertical upward, add the table weight.

## LES25□/Step Motor

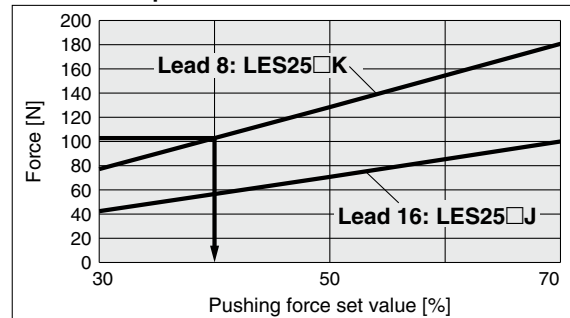

&lt;Pushing force set value–Force graph&gt;

## Allowable Duty Ratio

## Step Motor (Servo/24 VDC)

Pushing force set value [%]	Duty ratio [%]	Continuous pushing time [min]
30	—	—
50 or less	30 or less	5 or less
70 or less	20 or less	3 or less

## Servo Motor (24 VDC)

Pushing force set value [%]	Duty ratio [%]	Continuous pushing time [min]
50	—	—
75 or less	30 or less	5 or less
100 or less	20 or less	3 or less

\* The pushing force of the LES8□A is up to 75%.

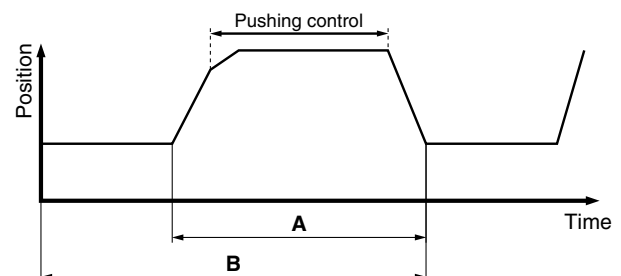



## Pushing Force Set Value–Force Graph

### Step Motor (Servo/24 VDC)

#### LES8□

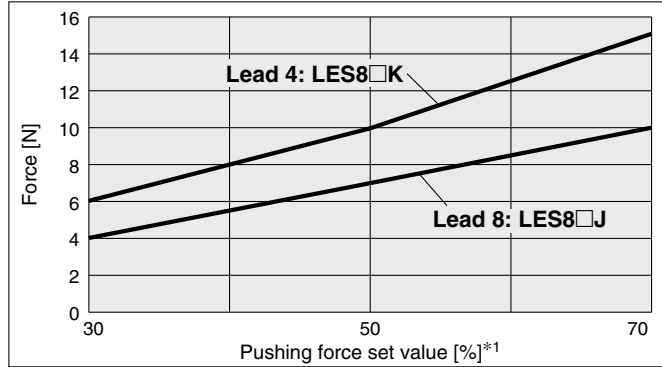

#### LES16□

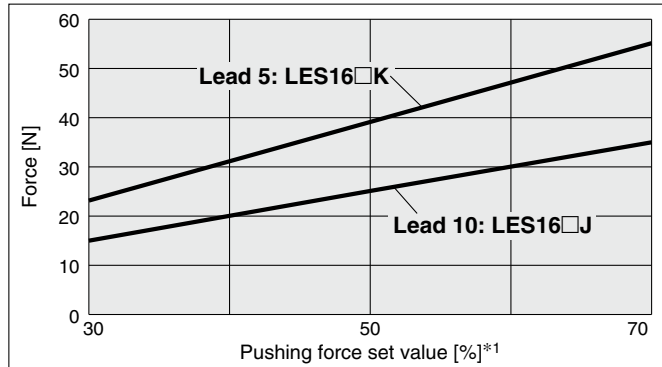

#### LES25□

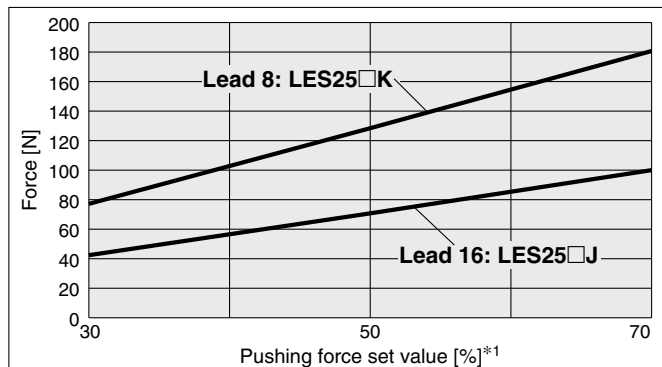

### Servo Motor (24 VDC)

#### LES8□A

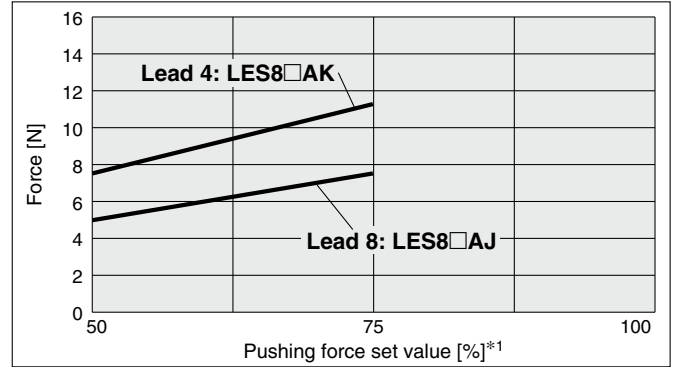

#### LES16□A

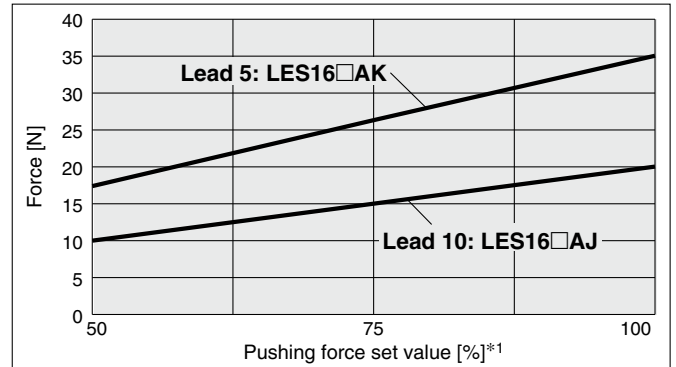

#### LES25□A

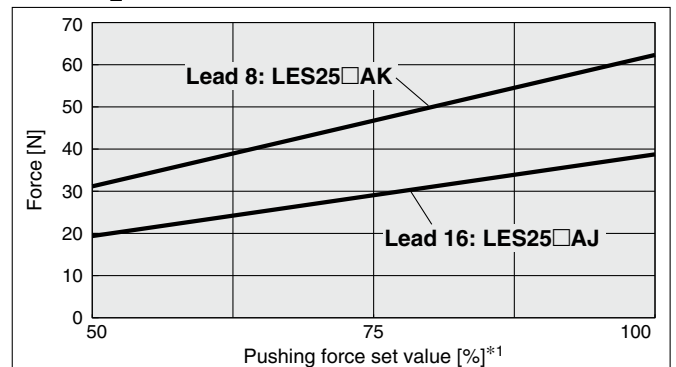

\*1 Set values for the controller

# LES Series

Incremental (Step Motor 24 VDC)

Incremental (Servo Motor 24 VDC)

## Table Accuracy

\* These values are initial guideline values.

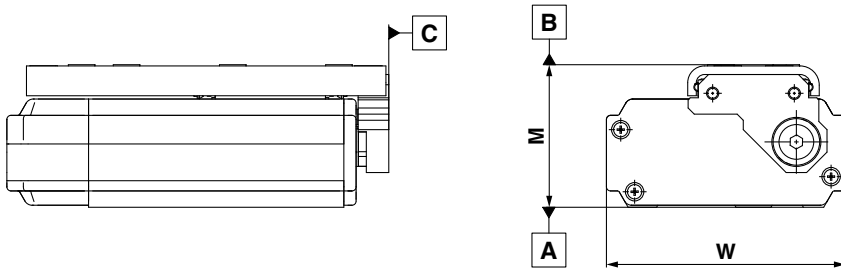

Model	LES8	LES16	LES25
B side parallelism to A side	0.4 mm		
B side traveling parallelism to A side	Refer to Graph 1.		
C side perpendicularity to A side	0.2 mm		
M dimension tolerance	±0.3 mm		
W dimension tolerance	±0.2 mm		

**Graph 1** B side traveling parallelism to A side

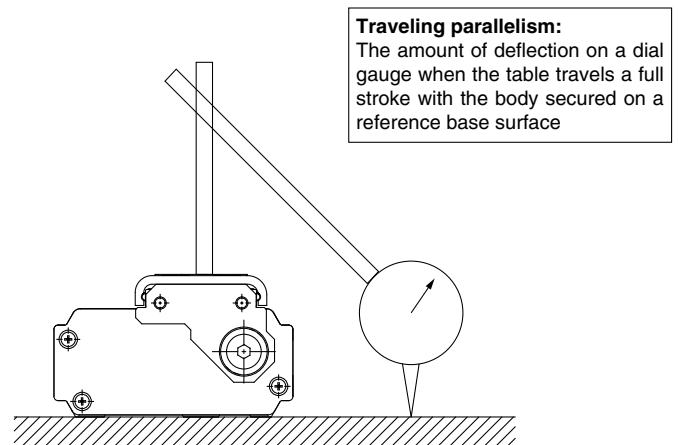
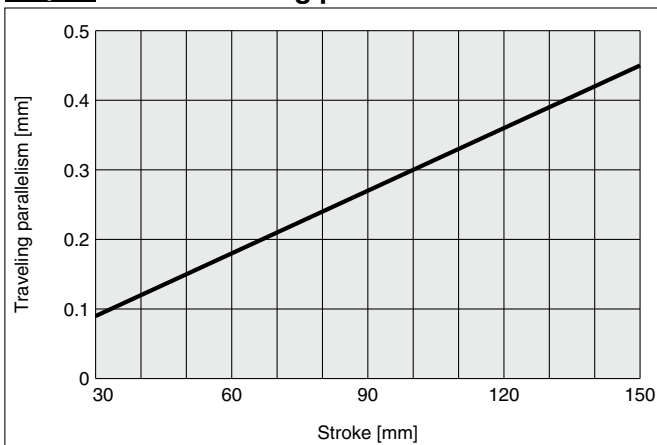

## Table Deflection (Reference Value)

\* These values are initial guideline values.

### Pitching moment

Table displacement due to pitch moment load  
Table displacement when loads are applied to the section marked with the arrow with the slide table stuck out.

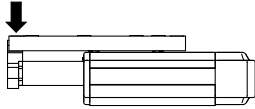

#### LES8

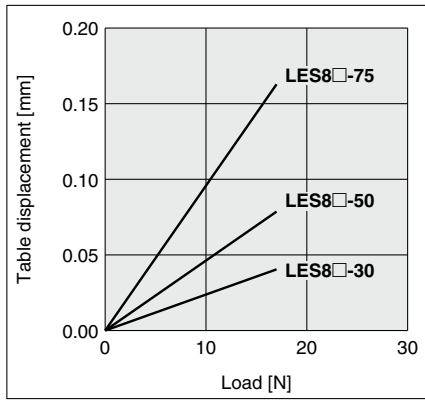

### Yawing moment

Table displacement due to yaw moment load  
Table displacement when loads are applied to the section marked with the arrow with the slide table stuck out.

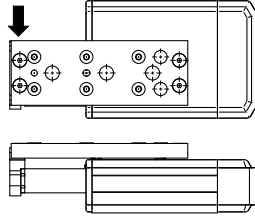

#### LES8

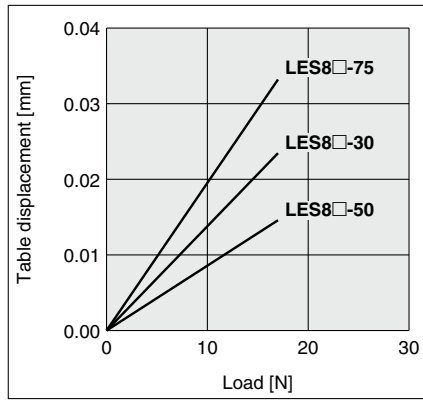

### Rolling moment

Table displacement due to roll moment load  
Table displacement of section A when loads are applied to the section F with the slide table retracted.

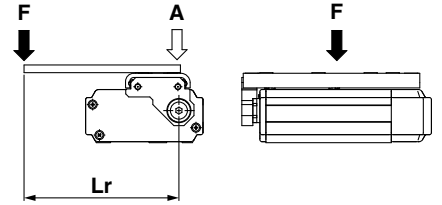

#### LES8

Lr = 80 mm

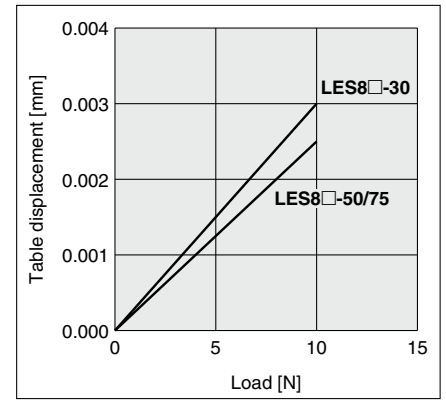

#### LES16

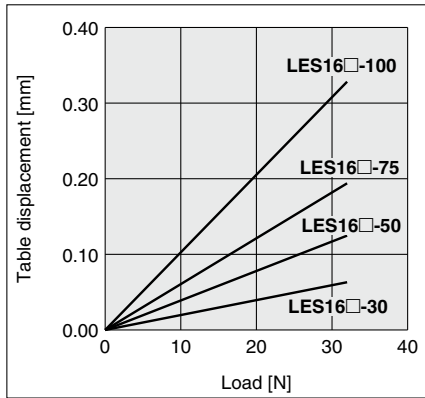

#### LES16

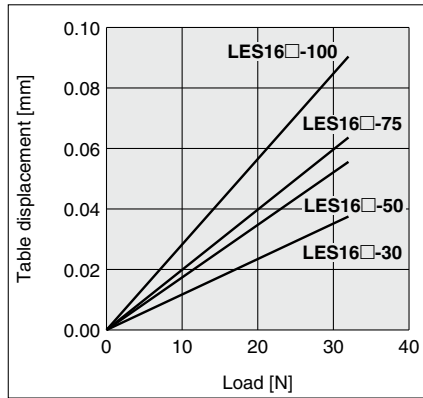

#### LES16

Lr = 60 mm

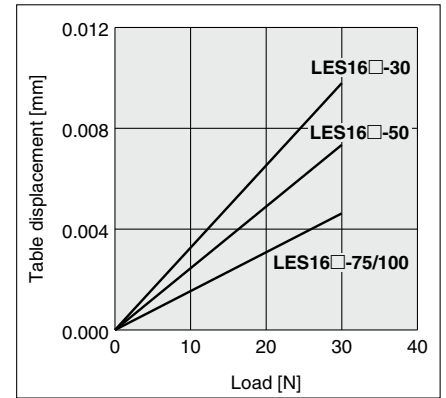

#### LES25

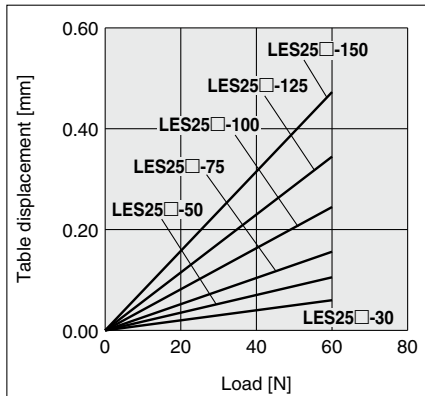

#### LES25

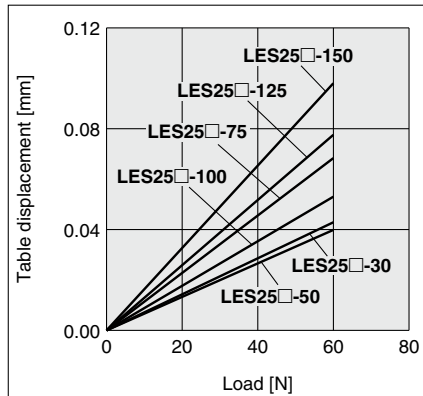

#### LES25

Lr = 100 mm

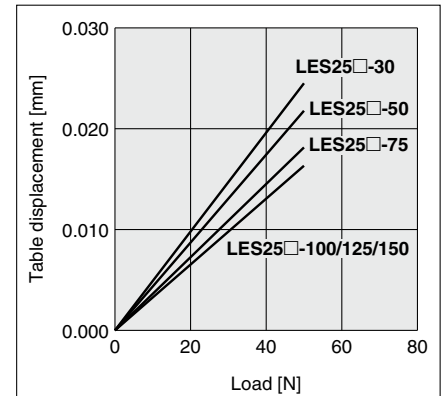

# Slide Table/Compact Type

## LES Series LES25



\* For details, refer to page 1343 and onward.



Compact type

### How to Order

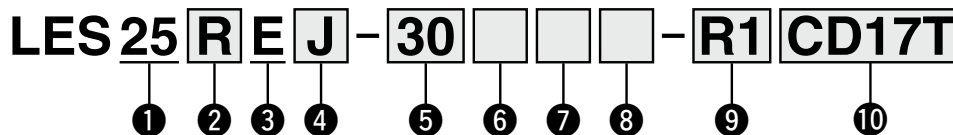

For details on controllers, refer to the next page.

#### 1 Size

25

#### 2 Motor mounting position

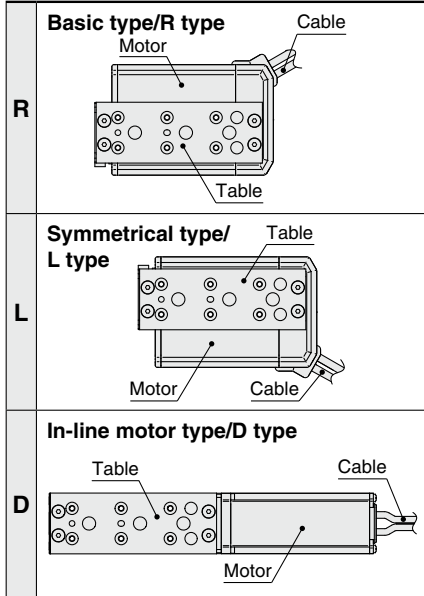

#### 3 Motor type

Symbol	Type	Compatible controllers/drivers
E	Battery-less absolute (Step motor 24 VDC)	JXC51 JXCP1 JXCEF
		JXC61 JXCD1 JXC9F
		JXCE1 JXCL1 JXCPF
		JXC91 JXCM1 JXCLF

#### 4 Lead [mm]

J	16
K	8

#### 5 Stroke [mm]

Stroke	Applicable stroke
30 to 150	30*1, 50, 75, 100, 125, 150

#### 6 Motor option

Nil	Without option
B	With lock*1

#### 7 Body option

Nil	Without option
S	Dust-protected*2

#### Applicable motor option chart

Motor mounting position	Size	Stroke	
		30	50 or more
R/L	25	×	○
D	25	○	○

#### 8 Mounting\*3

Symbol	Mounting	R type L type	D type
Nil	Without side holder	●	●
H	With side holder (4 pcs.)	—	●

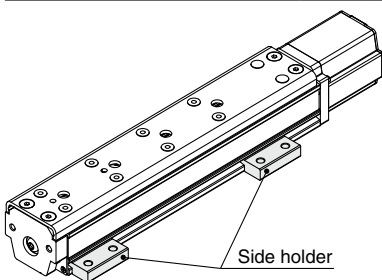

#### 9 Actuator cable type/length

Robotic cable [m]			
Nil	None	R8	8*4
R1	1.5	RA	10*4
R3	3	RB	15*4
R5	5	RC	20*4

## 10 Controller

Nil	Without controller
C□1□□	With controller



### Interface (Communication protocol/Input/Output)

Symbol	Type	Number of axes, Special specification	
		Standard	With STO sub-function
5	Parallel input (NPN)	●	
6	Parallel input (PNP)	●	
E	EtherCAT	●	●
9	EtherNet/IP™	●	●
P	PROFINET	●	●
D	DeviceNet®	●	
L	IO-Link	●	●
M	CC-Link	●	

### Mounting

7	Screw mounting
8*5	DIN rail

### Number of axes, Special specification

Symbol	Number of axes	Specification
1	Single axis	Standard
F	Single axis	With STO sub-function

### Communication plug connector, I/O cable\*6

Symbol	Type	Applicable interface
Nil	Without accessory	—
S	Straight type communication plug connector	DeviceNet®
T	T-branch type communication plug connector	CC-Link Ver. 1.10
1	I/O cable (1.5 m)	Parallel input (NPN) Parallel input (PNP)
3	I/O cable (3 m)	
5	I/O cable (5 m)	

- \*1 As the applicable motor mounting positions and motor options vary depending on the stroke, refer to the applicable motor option chart on page 659.
- \*2 For R/L type (IP5X equivalent), a scraper is mounted on the rod cover, and gaskets are mounted on both the end covers. For D type, a scraper is mounted on the rod cover.

- \*3 For details, refer to page 667.
- \*4 Produced upon receipt of order
- \*5 The DIN rail is not included. It must be ordered separately.
- \*6 Select "Nil," "S," or "T" for DeviceNet®, CC-Link, or parallel input. Select "Nil," "1," "3," or "5" for parallel input.

## ⚠ Caution

### [CE/UKCA-compliant products]

EMC compliance was tested by combining the electric actuator LES series and the controller JXC series.

The EMC depends on the configuration of the customer's control panel and the relationship with other electrical equipment and wiring. Therefore, compliance with the EMC directive cannot be certified for SMC components incorporated into the customer's equipment under actual operating conditions. As a result, it is necessary for the customer to verify compliance with the EMC directive for the machinery and equipment as a whole.

### [Precautions relating to differences in controller versions]

When the JXC series is to be used in combination with the battery-less absolute encoder, use a controller that is version V3.4 or S3.4 or higher. For details, refer to pages 1077 and 1078.

### [UL certification]

The JXC series controllers used in combination with electric actuators are UL certified.

## The actuator and controller are sold as a package.

Confirm that the combination of the controller and actuator is correct.

### <Check the following before use.>

- Check the actuator label for the model number. This number should match that of the controller.
- Check that the Parallel I/O configuration matches (NPN or PNP).

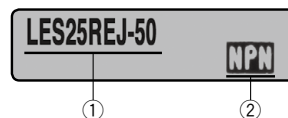

\* Refer to the Operation Manual for using the products. Please download it via our website: <https://www.smcworld.com>

Type	Step data input type	EtherCAT direct input type	EtherCAT direct input type with STO sub-function	EtherNet/IP™ direct input type	EtherNet/IP™ direct input type with STO sub-function	PROFINET direct input type	PROFINET direct input type with STO sub-function	DeviceNet® direct input type	IO-Link direct input type	IO-Link direct input type with STO sub-function	CC-Link direct input type
Series	JXC51 JXC61	JXCE1	JXCEF	JXC91	JXC9F	JXCP1	JXC PF	JXCD1	JXCL1	JXCLF	JXCM1
Features	Parallel I/O	EtherCAT direct input	EtherCAT direct input with STO sub-function	EtherNet/IP™ direct input	EtherNet/IP™ direct input with STO sub-function	PROFINET direct input	PROFINET direct input with STO sub-function	DeviceNet® direct input	IO-Link direct input	IO-Link direct input with STO sub-function	CC-Link direct input
Compatible motor	Battery-less absolute (Step motor 24 VDC)										
Max. number of step data	64 points										
Power supply voltage	24 VDC										
Reference page	1017					1063					

# LES Series

Battery-less Absolute (Step Motor 24 VDC)

## Specifications

### Battery-less Absolute (Step Motor 24 VDC)

Model		LES25□E		
Actuator specifications	Stroke [mm]	30, 50, 75, 100, 125, 150		
	Work load [kg] <sup>*1</sup>	Horizontal	5	
		Vertical	5	2.5
	Pushing force 30 to 70% [N] <sup>*2 *3</sup>	77 to 180	43 to 100	
	Speed [mm/s] <sup>*1 *3</sup>	10 to 200	20 to 400	
	Pushing speed [mm/s]	10 to 20	20	
	Max. acceleration/deceleration [mm/s <sup>2</sup> ]	5000		
	Positioning repeatability [mm]	±0.05		
	Lost motion [mm] <sup>*4</sup>	0.3 or less		
	Screw lead [mm]	8	16	
	Impact/Vibration resistance [m/s <sup>2</sup> ] <sup>*5</sup>	50/20		
	Actuation type	Slide screw + Belt (R/L type), Slide screw (D type)		
	Guide type	Linear guide (Circulating type)		
	Operating temperature range [°C]	5 to 40		
Operating humidity range [%RH]	90 or less (No condensation)			
Enclosure	IP30			
Electric specifications	Motor size	□42		
	Motor type	Battery-less absolute (Step motor 24 VDC)		
	Encoder	Battery-less absolute		
	Power supply voltage [V]	24 VDC ±10%		
Lock unit specifications	Power [W] <sup>*6 *8</sup>	Max. power 67		
	Type	Non-magnetizing lock		
	Holding force [N]	500	77	
	Power [W] <sup>*8</sup>	5		
	Rated voltage [V]	24 VDC ±10%		

\*1 Speed changes according to the work load. Check the "Speed-Work Load Graph (Guide)" on page 642.

\*2 Pushing force accuracy is ±20% (F.S.).

\*3 The speed and force may change depending on the cable length, load, and mounting conditions. Furthermore, if the cable length exceeds 5 m, then it will decrease by up to 10% for each 5 m. (At 15 m: Reduced by up to 20%)

\*4 A reference value for correcting errors in reciprocal operation

\*5 Vibration resistance: No malfunction occurred in a test ranging between 45 to 2000 Hz. The test was performed in both an axial direction and a perpendicular direction to the lead screw. (The test was performed with the actuator in the initial state.)

Impact resistance: No malfunction occurred when the actuator was tested with a drop tester in both an axial direction and a perpendicular direction to the lead screw. (The test was performed with the actuator in the initial state.)

\*6 Indicates the max. power during operation (including the controller)

This value can be used for the selection of the power supply.

\*7 With lock only

\*8 For an actuator with lock, add the power for the lock.

## Weight

### Battery-less Absolute (Step Motor 24 VDC)

[kg]

Stroke [mm]		Without lock						With lock					
		30	50	75	100	125	150	30	50	75	100	125	150
Model	LES25 <sup>R</sup>	1.81	2.07	2.41	3.21	3.44	3.68	—	2.34	2.68	3.48	3.71	3.95
	LES25 <sup>D</sup>	1.82	2.05	2.35	3.07	3.27	3.47	2.08	2.31	2.61	3.33	3.53	3.74



## Construction: Basic Type/R Type, Symmetrical Type/L Type

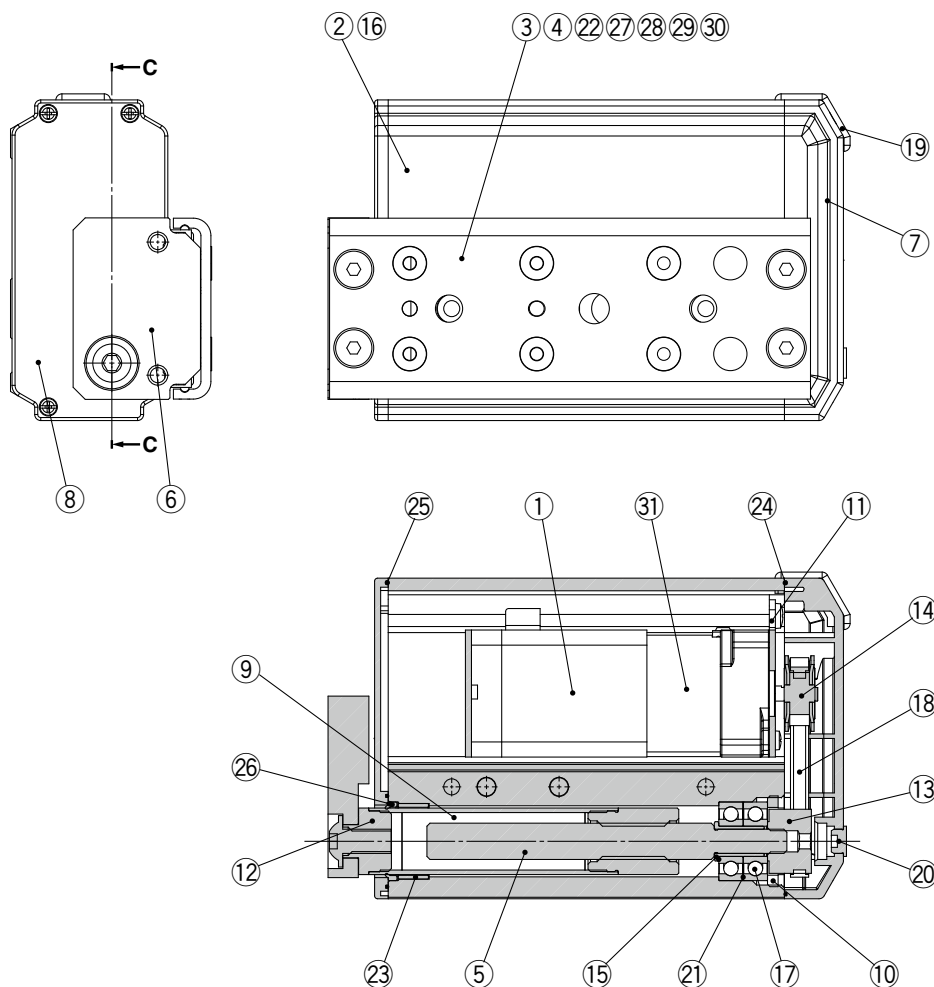

### Component Parts

No.	Description	Material	Note
1	Motor	—	—
2	Body	Aluminum alloy	Anodized
3	Table	Stainless steel	Heat treatment + Electroless nickel plating
4	Guide block	Stainless steel	Heat treatment
5	Lead screw	Stainless steel	Heat treatment + Special treatment
6	End plate	Aluminum alloy	Anodized
7	Pulley cover	Synthetic resin	—
8	End cover	Synthetic resin	—
9	Rod	Stainless steel	—
10	Bearing stopper	Structural steel	Electroless nickel plating
		Brass	Electroless nickel plating (LES25R/L□ only)
11	Motor plate	Structural steel	—
12	Socket	Structural steel	Electroless nickel plating
13	Lead screw pulley	Aluminum alloy	—
14	Motor pulley	Aluminum alloy	—
15	Spacer	Stainless steel	LES25R/L□ only
16	Origin stopper	Structural steel	Electroless nickel plating
17	Bearing	—	—
18	Belt	—	—
19	Grommet	Synthetic resin	—
20	Cap	Silicone rubber	—
21	Sim ring	Structural steel	—

No.	Description	Material	Note
22	Stopper	Structural steel	—
23	Bushing	—	Dust-protected option only
24	Pulley gasket	NBR	Dust-protected option only
25	End gasket	NBR	Dust-protected option only
26	Scraper	NBR	Dust-protected option only
27	Cover	Synthetic resin	—
28	Return guide	Synthetic resin	—
29	Cover support	Stainless steel	—
30	Steel ball	Special steel	—
31	Lock	—	With lock only

### Replacement Parts/Belt

Size	Order no.	Note
LES25□	LE-D-1-3	—

### Replacement Parts/Grease Pack

Applied portion	Order no.
Guide unit	GR-S-010 (10 g) GR-S-020 (20 g)

# LES Series

Battery-less Absolute (Step Motor 24 VDC)

## Construction: In-line Motor Type/D Type

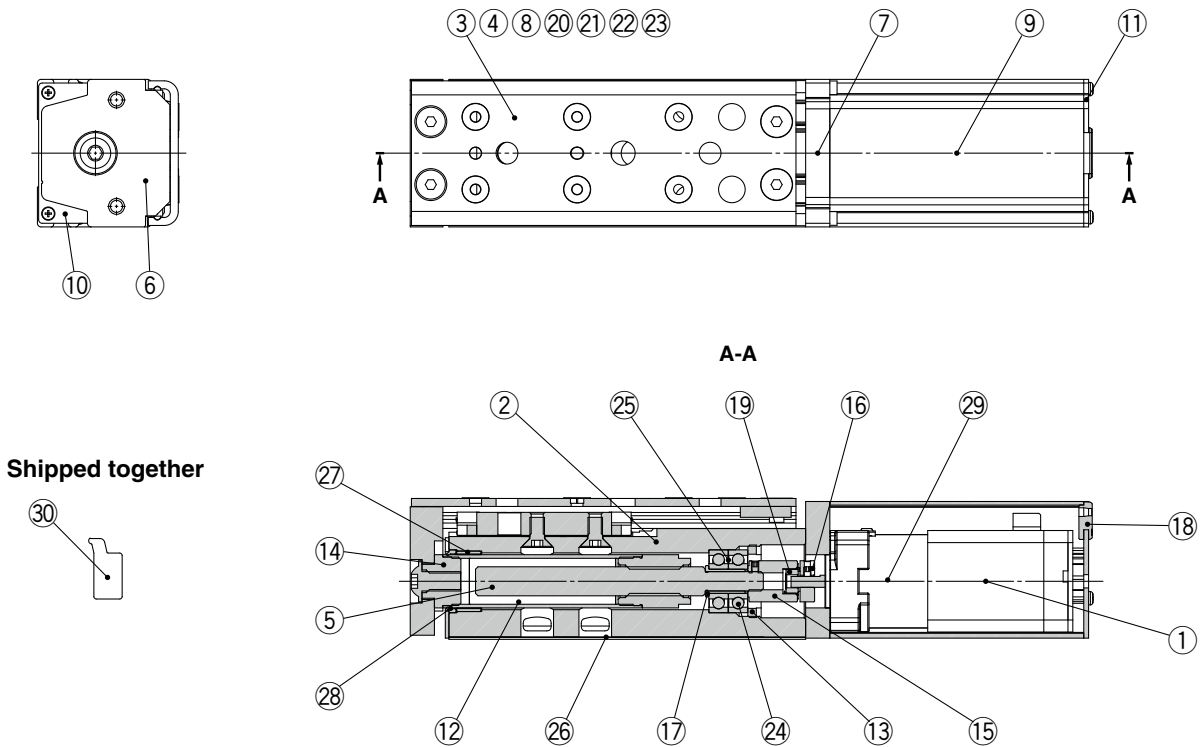

### Component Parts

No.	Description	Material	Note
1	Motor	—	—
2	Body	Aluminum alloy	Anodized
3	Table	Stainless steel	Heat treatment + Electroless nickel plating
4	Guide block	Stainless steel	Heat treatment
5	Lead screw	Stainless steel	Heat treatment + Special treatment
6	End plate	Aluminum alloy	Anodized
7	Motor flange	Aluminum alloy	Anodized
8	Stopper	Structural steel	—
9	Motor cover	Aluminum alloy	Anodized
10	End cover	Aluminum alloy	Anodized
11	Motor end cover	Aluminum alloy	Anodized
12	Rod	Stainless steel	—
13	Bearing stopper	Structural steel	Electroless nickel plating
		Brass	Electroless nickel plating (LES25D□ only)
14	Socket	Structural steel	Electroless nickel plating
15	Hub (Lead screw side)	Aluminum alloy	—
16	Hub (Motor side)	Aluminum alloy	—
17	Spacer	Stainless steel	LES25D□ only
18	Grommet	NBR	—
19	Spider	NBR	—
20	Cover	Synthetic resin	—

No.	Description	Material	Note
21	Return guide	Synthetic resin	—
22	Cover support	Stainless steel	—
23	Steel ball	Special steel	—
24	Bearing	—	—
25	Sim ring	Structural steel	—
26	Masking tape	—	—
27	Bushing	—	Dust-protected option only
28	Scraper	NBR	Dust-protected option only
29	Lock	—	With lock only
30	Side holder	Aluminum alloy	Anodized

### Optional Parts/Side Holder

Model	Order no.
LES25D	LE-D-3-3

### Replacement Parts/Grease Pack

Applied portion	Order no.
Guide unit	GR-S-010 (10 g) GR-S-020 (20 g)

## Dimensions: Basic Type/R Type

### LES25RE

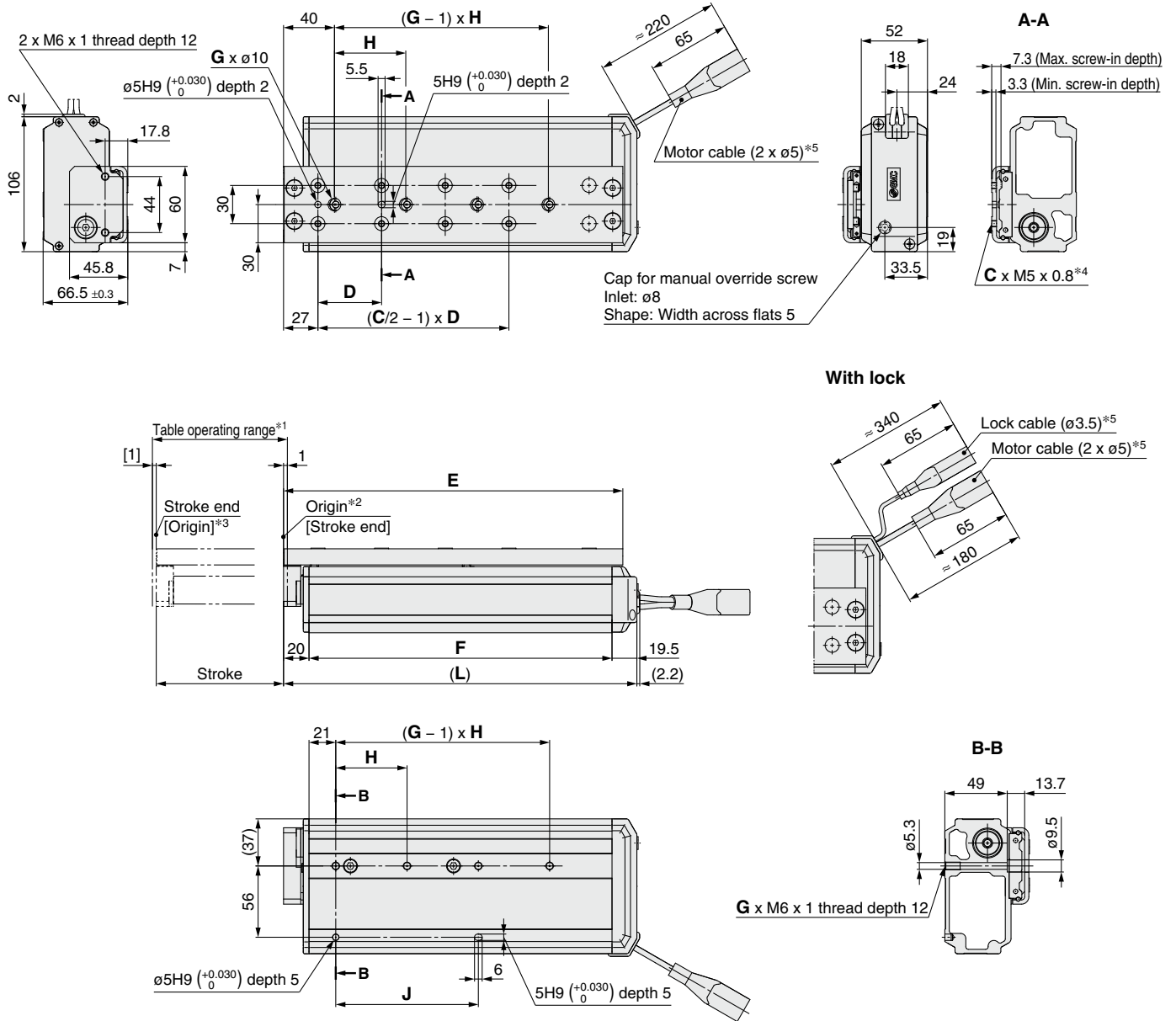

- \*1 This is the range within which the table can move when it returns to origin.  
Make sure that workpieces mounted on the table do not interfere with other workpieces or the facilities around the table.
- \*2 Position after returning to origin
- \*3 [ ] for when the direction of return to origin has changed
- \*4 If workpiece retaining screws are too long, they can touch the guide block and cause a malfunction.  
Use screws that are between the maximum and minimum screw-in depths in length.
- \*5 Secure the motor cable and lock cable so that the cables are not repeatedly bent.

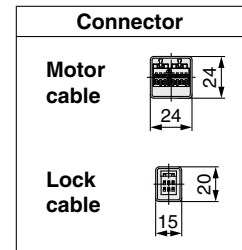

## Dimensions

[mm]

Model	L	C	D	E	F	G	H	J
LES25RE□-30□-□□□□□□	144.5	4	48	133.5	105	2	46	46
LES25RE□-50□-□□□□□□	170.5	6	42	159.5	131	2	84	84
LES25RE□-75□-□□□□□□	204.5	6	55	193.5	165	2	112	112
LES25RE□-100□-□□□□□□	277.5	8	50	266.5	238	4	56	112
LES25RE□-125□-□□□□□□	302.5	8	55	291.5	263	4	59	118
LES25RE□-150□-□□□□□□	327.5	8	62	316.5	288	4	62	124

# LES Series

Battery-less Absolute (Step Motor 24 VDC)

## Dimensions: Symmetrical Type/L Type

### LES25LE

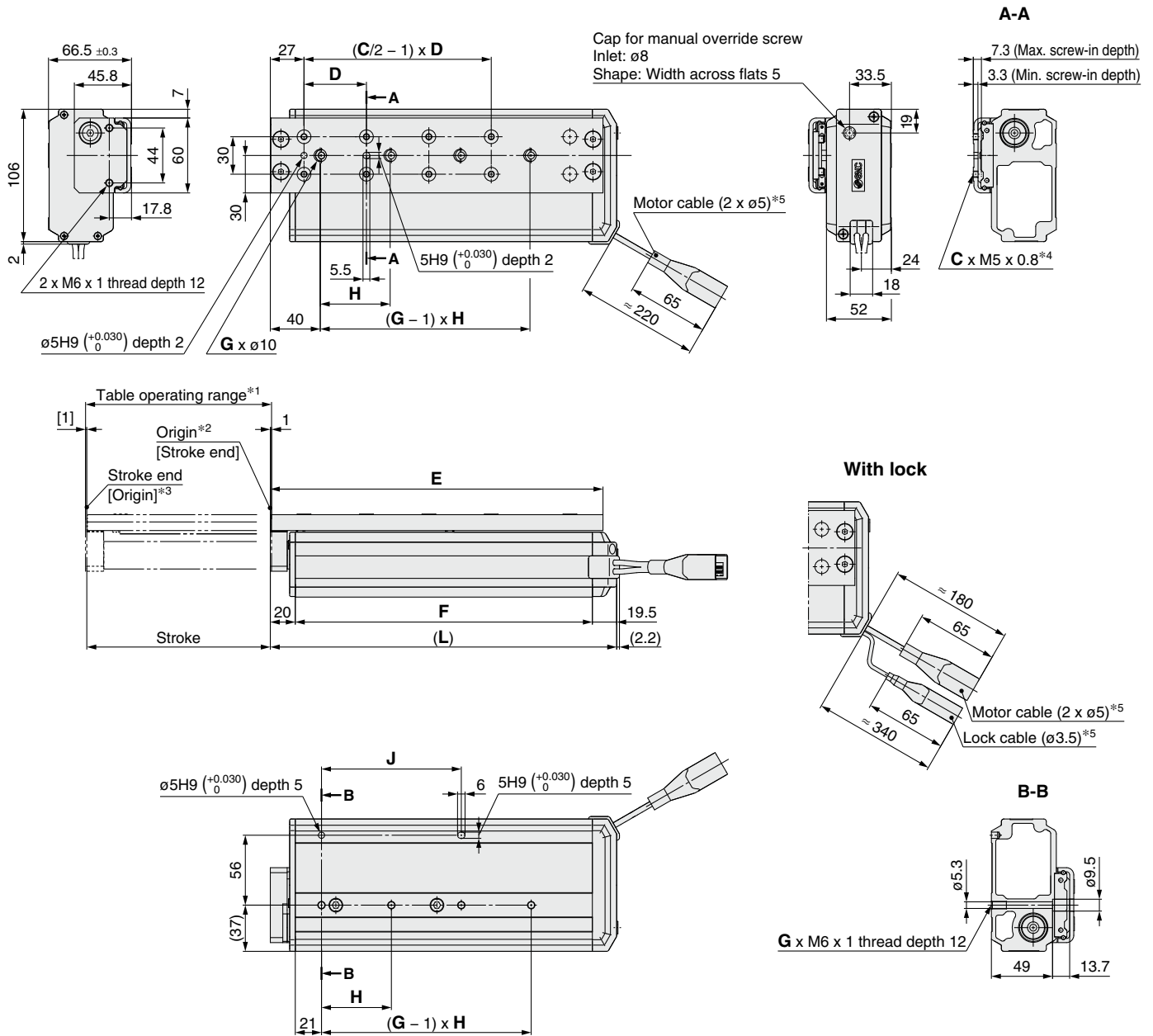

- \*1 This is the range within which the table can move when it returns to origin.  
Make sure that workpieces mounted on the table do not interfere with other workpieces or the facilities around the table.
- \*2 Position after returning to origin
- \*3 [ ] for when the direction of return to origin has changed
- \*4 If workpiece retaining screws are too long, they can touch the guide block and cause a malfunction.  
Use screws that are between the maximum and minimum screw-in depths in length.
- \*5 Secure the motor cable and lock cable so that the cables are not repeatedly bent.

### Dimensions

[mm]

Model	L	C	D	E	F	G	H	J
LES25LE□-30□-□□□□□□	144.5	4	48	133.5	105	2	46	46
LES25LE□-50□-□□□□□□	170.5	6	42	159.5	131	2	84	84
LES25LE□-75□-□□□□□□	204.5	6	55	193.5	165	2	112	112
LES25LE□-100□-□□□□□□	277.5	8	50	266.5	238	4	56	112
LES25LE□-125□-□□□□□□	302.5	8	55	291.5	263	4	59	118
LES25LE□-150□-□□□□□□	327.5	8	62	316.5	288	4	62	124

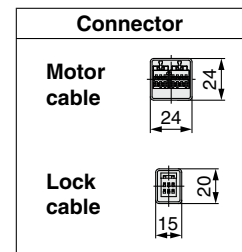

## Dimensions: In-line Motor Type/D Type

### LES25DE

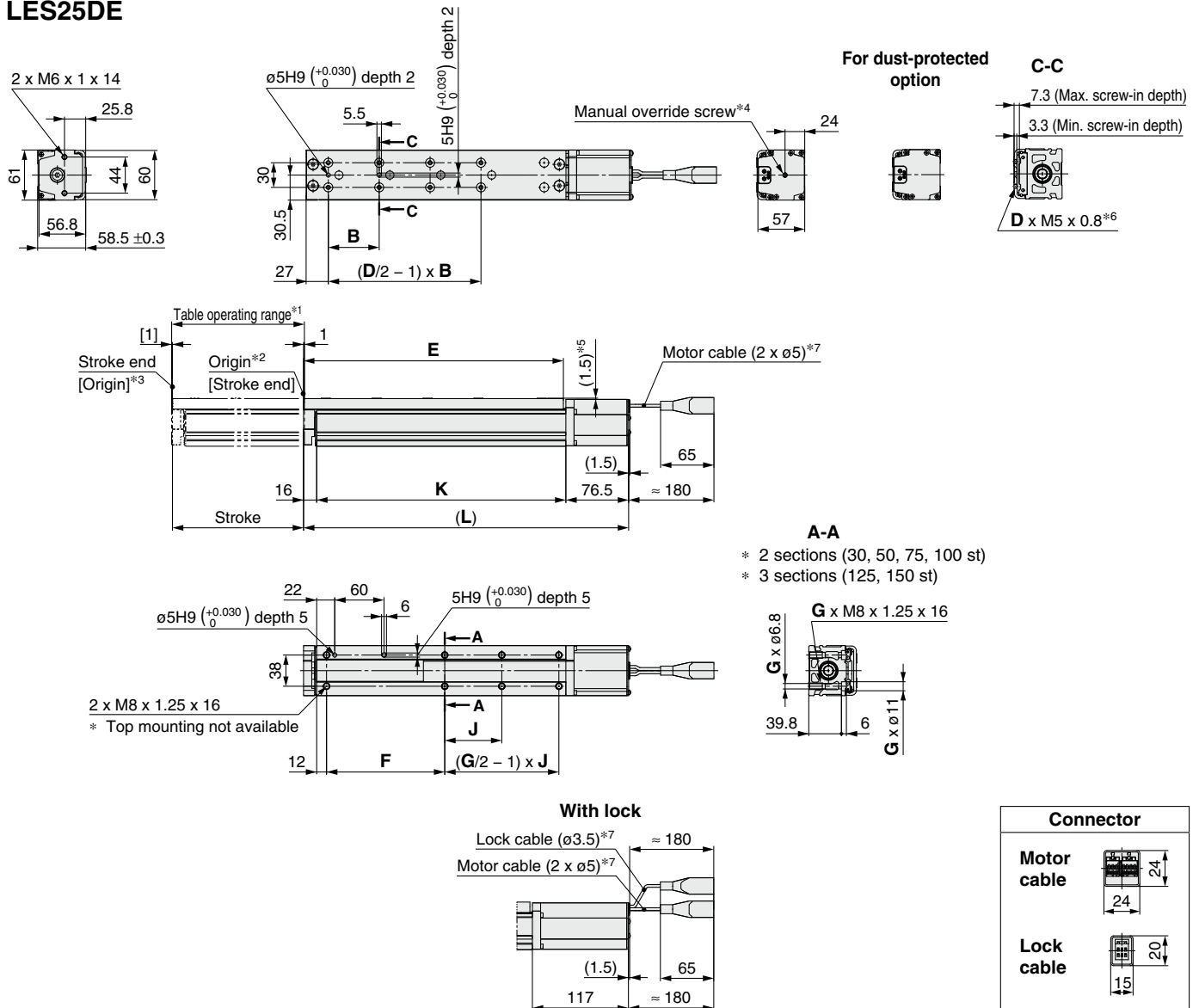

- \*1 This is the range within which the table can move when it returns to origin. Make sure that workpieces mounted on the table do not interfere with other workpieces or the facilities around the table.
- \*2 Position after returning to origin
- \*3 [ ] for when the direction of return to origin has changed
- \*4 The distance between the motor end cover and the manual override screw is up to 4 mm. The motor end cover hole size is ø5.5.
- \*5 The table is lower than the motor cover.
- \*6 If workpiece retaining screws are too long, they can touch the guide block and cause a malfunction. Use screws that are between the maximum and minimum screw-in depths in length.
- \*7 Secure the motor cable and lock cable so that the cables are not repeatedly bent.

### Dimensions

Model	(L)	B	D	E	F	G	J	K
LES25DE□-30□-□□□□□□	214	48	4	133.5	81	4	19	121.5
LES25DE□-30B□-□□□□□□	254.5							
LES25DE□-50□-□□□□□□	240	42	6	159.5	87	4	39	147.5
LES25DE□-50B□-□□□□□□	280.5							
LES25DE□-75□-□□□□□□	274	55	6	193.5	96	4	64	181.5
LES25DE□-75B□-□□□□□□	314.5							
LES25DE□-100□-□□□□□□	347	50	8	266.5	144	4	89	254.5
LES25DE□-100B□-□□□□□□	387.5							
LES25DE□-125□-□□□□□□	372	55	8	291.5	144	6	57	279.5
LES25DE□-125B□-□□□□□□	412.5							
LES25DE□-150□-□□□□□□	397	62	8	316.5	144	6	69.5	304.5
LES25DE□-150B□-□□□□□□	437.5							

# LES Series

Battery-less Absolute (Step Motor 24 VDC)

## Side Holder (In-line Motor Type/D Type)

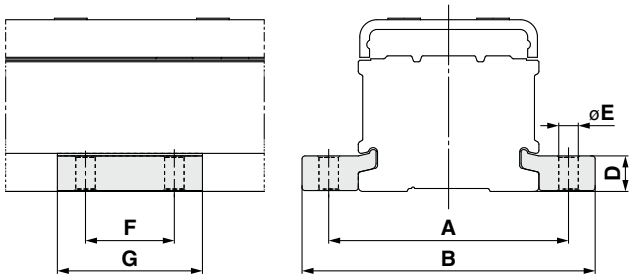

Part no.*1	A	B	D	E	F	G	Applicable model
LE-D-3-3	81	99	12	6.6	30	49	LES25DE

[mm]

\*1 Part number for 1 side holder





# Slide Table Compact Type

## LES Series LES8, 16, 25



\* For details, refer to page 1343 and onward.



### How to Order



Basic type (R type) Symmetrical type (L type) In-line motor type (D type)

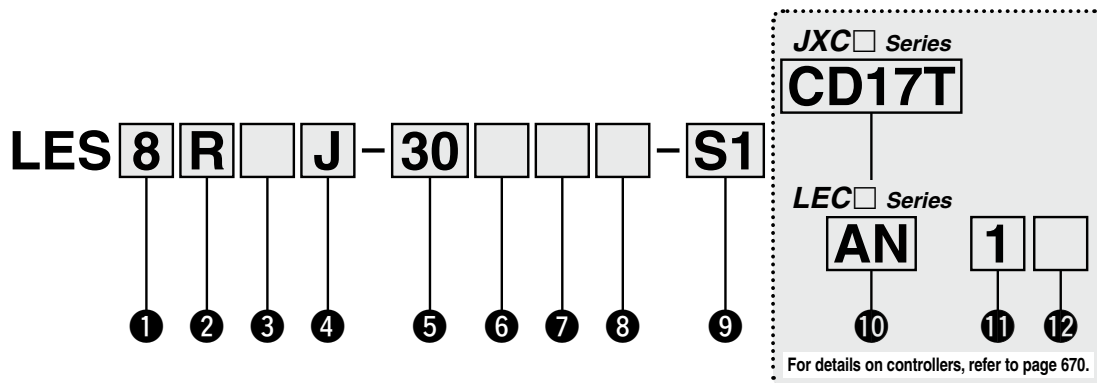

#### 1 Size

8
16
25

#### 4 Lead [mm]

Symbol	LES8	LES16	LES25
J	8	10	16
K	4	5	8

#### 5 Stroke [mm]

Stroke	Note	
	Size	Applicable stroke
30 to 75	8	30*2, 50*2, 75
30 to 100	16	30*2, 50*2, 75, 100
30 to 150	25	30*2, 50, 75, 100, 125, 150

#### 2 Motor mounting position

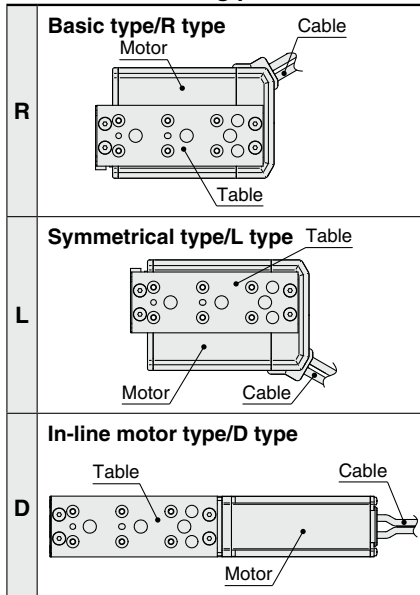

#### 3 Motor type

Symbol	Type	Compatible controllers/drivers
Nil	Step motor (Servo/24 VDC)	JXC51 JXCEF
		JXC61 JXC9F
		JXCE1 JXCPE
		JXC91 JXCLF
		JXCP1 JXCD1
		JXCL1 LECP1
		JXCM1 LECPA
		JXCM1 LECPA
A	Servo motor*1 (24 VDC)	LECA6

#### 6 Motor option

Nil	Without option
B	With lock*2

#### 7 Body option

Nil	Without option
S	Dust protected*3

#### Applicable motor option chart

Motor mounting position	Size	Stroke		
		30	50	75 or more
R/L	8	x	x	○
	16	x	x	○
	25	x	○	○
D	8	○	○	○
	16	○	○	○
	25	○	○	○

#### 9 Actuator cable type/length\*6

Standard cable [m]		Robotic cable [m]			
Nil	None	R1	1.5	RA	10*5
S1	1.5*8	R3	3	RB	15*5
S3	3*8	R5	5	RC	20*5
S5	5*8	R8	8*5		

#### 8 Mounting\*4

Symbol	Mounting	R type L type	D type
Nil	Without side holder	●	●
H	With side holder (4 pcs.)	—	●

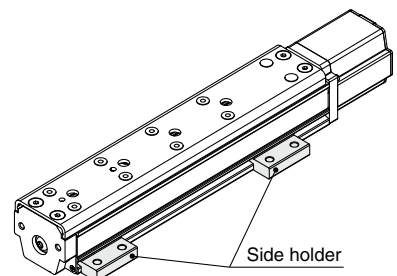

# Slide Table/Compact Type **LES Series**

Incremental (Step Motor 24 VDC)

Incremental (Servo Motor 24 VDC)

## JXC Series (For details, refer to page 671.)

### 10 Controller

Nil	Without controller
C□1□□	With controller

**C D 1 7 T**

### Interface (Communication protocol/Input/Output)

Symbol	Type	Number of axes, Special specification	
		Standard	With STO sub-function
5	Parallel input (NPN)	●	
6	Parallel input (PNP)	●	
E	EtherCAT	●	●
9	EtherNet/IP™	●	●
P	PROFINET	●	●
D	DeviceNet®	●	
L	IO-Link	●	●
M	CC-Link	●	

### Mounting

7	Screw mounting
8*12	DIN rail

### Number of axes, Special specification

Symbol	Number of axes	Specification
1	Single axis	Standard
F	Single axis	With STO sub-function

### Communication plug connector, I/O cable\*13

Symbol	Type	Applicable interface
Nil	Without accessory	—
S	Straight type communication plug connector	DeviceNet®
T	T-branch type communication plug connector	CC-Link Ver. 1.10
1	I/O cable (1.5 m)	Parallel input (NPN) Parallel input (PNP)
3	I/O cable (3 m)	
5	I/O cable (5 m)	



## LEC Series (For details, refer to page 671.)

**AN 1 □**

10    11    12

### 10 Controller/Driver type\*7

Nil	Without controller/driver	
6N	<b>LECA6</b>	NPN
6P	(Step data input type)	PNP
1N	<b>LECP1</b> *8	NPN
1P	(Programless type)	PNP
AN	<b>LECPA</b> *8 *9	NPN
AP	(Pulse input type)	PNP

### 11 I/O cable length\*10

Nil	Without cable (Without communication plug connector)
1	1.5 m
3	3 m*11
5	5 m*11

### 12 Controller/Driver mounting

Nil	Screw mounting
D	DIN rail*12



- \*1 LES25DA is not available.
- \*2 As the applicable motor mounting positions and motor options vary depending on the stroke, refer to the applicable motor option chart on page 669.
- \*3 For R/L type (IP5X equivalent), a scraper is mounted on the rod cover, and gaskets are mounted on both the end covers. For D type, a scraper is mounted on the rod cover.
- \*4 Refer to page 685 for details.
- \*5 Produced upon receipt of order (Robotic cable only)
- \*6 The standard cable should only be used on fixed parts. For use on moving parts, select the robotic cable. Refer to pages 1092 and 1093 if only the actuator cable is required.
- \*7 For details on controllers/drivers and compatible motors, refer to the compatible controllers/drivers on the next page.

- \*8 Only available for the motor type "Step motor"
- \*9 When pulse signals are open collector, order the current limiting resistor (LEC-PA-R-□) on page 1062 separately.
- \*10 When "Without controller/driver" is selected for controller/driver types, I/O cable cannot be selected. Refer to page 1037 (For LECA6), page 1047 (For LECP1), or page 1062 (For LECPA) if an I/O cable is required.
- \*11 When "Pulse input type" is selected for controller/driver types, pulse input usable only with differential. Only 1.5 m cables usable with open collector
- \*12 The DIN rail is not included. It must be ordered separately.
- \*13 Select "Nil," "S," or "T" for DeviceNet®, CC-Link, or parallel input. Select "Nil," "1," "3," or "5" for parallel input.

## ⚠ Caution

### [CE/UKCA-compliant products]

- ① EMC compliance was tested by combining the electric actuator LES series and the controller LEC/JXC series. The EMC depends on the configuration of the customer's control panel and the relationship with other electrical equipment and wiring. Therefore, compliance with the EMC directive cannot be certified for SMC components incorporated into the customer's equipment under actual operating conditions. As a result, it is necessary for the customer to verify compliance with the EMC directive for the machinery and equipment as a whole.
- ② For the incremental (servo motor 24 VDC) specification, EMC compliance was tested by installing a noise filter set (LEC-NFA). Refer to page 1037 for the noise filter set. Refer to the LECA series Operation Manual for installation.

### [UL-compliant products (For the LEC series)]

When compliance with UL is required, the electric actuator and controller/driver should be used with a UL1310 Class 2 power supply.

## The actuator and controller/driver are sold as a package.

Confirm that the combination of the controller/driver and the actuator is correct.

### <Check the following before use.>

- ① Check the actuator label for model number. This number should match that of the controller/driver.
- ② Check that the Parallel I/O configuration matches (NPN or PNP).

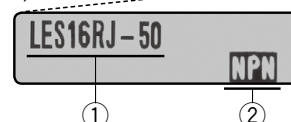





\* Refer to the Operation Manual for using the products. Please download it via our website: <https://www.smcworld.com>











# LES Series

Incremental (Step Motor 24 VDC)

Incremental (Servo Motor 24 VDC)

## Compatible Controllers/Drivers

Type	Step data input type	Step data input type	Programless type	Pulse input type
				
Series	<b>JXC51 JXC61</b>	<b>LECA6</b>	<b>LECP1</b>	<b>LECPA</b>
Features	Parallel I/O	Parallel I/O	Capable of setting up operation (step data) without using a PC or teaching box	Operation by pulse signals
Compatible motor	Step motor (Servo/24 VDC)	Servo motor (24 VDC)	Step motor (Servo/24 VDC)	
Max. number of step data	64 points		14 points	—
Power supply voltage	24 VDC			
Reference page	1017	1031	1042	1057

Type	EtherCAT direct input type	EtherCAT direct input type with STO sub-function	EtherNet/IP™ direct input type	EtherNet/IP™ direct input type with STO sub-function	PROFINET direct input type	PROFINET direct input type with STO sub-function	DeviceNet® direct input type	IO-Link direct input type	IO-Link direct input type with STO sub-function	CC-Link direct input type
										
Series	<b>JXCE1</b>	<b>JXCEF</b>	<b>JXC91</b>	<b>JXC9F</b>	<b>JXCP1</b>	<b>JXC9F</b>	<b>JXCD1</b>	<b>JXCL1</b>	<b>JXCLF</b>	<b>JXCM1</b>
Features	EtherCAT direct input	EtherCAT direct input with STO sub-function	EtherNet/IP™ direct input	EtherNet/IP™ direct input with STO sub-function	PROFINET direct input	PROFINET direct input with STO sub-function	DeviceNet® direct input	IO-Link direct input	IO-Link direct input with STO sub-function	CC-Link direct input
Compatible motor	Step motor (Servo/24 VDC)									
Max. number of step data	64 points									
Power supply voltage	24 VDC									
Reference page	1063									

## Specifications

### Step Motor (Servo/24 VDC)

Model		LES8□		LES16□		LES25□		
Actuator specifications	Stroke [mm]	30, 50, 75		30, 50, 75, 100		30, 50, 75, 100, 125, 150		
	Work load [kg] <sup>*1</sup>	Horizontal	1		3		5	
		Vertical	0.5	0.25	3	1.5	5	2.5
	Pushing force 30 to 70% [N] <sup>*2 *3</sup>		6 to 15	4 to 10	23.5 to 55	15 to 35	77 to 180	43 to 100
	Speed [mm/s] <sup>*1 *3</sup>		10 to 200	20 to 400	10 to 200	20 to 400	10 to 200	20 to 400
	Pushing speed [mm/s]		10 to 20	20	10 to 20	20	10 to 20	20
	Max. acceleration/deceleration [mm/s <sup>2</sup> ]		5000					
	Positioning repeatability [mm]		±0.05					
	Lost motion [mm] <sup>*4</sup>		0.3 or less					
	Screw lead [mm]		4	8	5	10	8	16
	Impact/Vibration resistance [m/s <sup>2</sup> ] <sup>*5</sup>		50/20					
	Actuation type		Slide screw + Belt (R/L type), Slide screw (D type)					
	Guide type		Linear guide (Circulating type)					
	Operating temperature range [°C]		5 to 40					
Operating humidity range [%RH]		90 or less (No condensation)						
Enclosure		IP30						
Electric specifications	Motor size	□20		□28		□42		
	Motor type	Step motor (Servo/24 VDC)						
	Encoder	Incremental						
	Power supply voltage [V]	24 VDC ±10%						
Lock unit specifications	Power [W] <sup>*6 *8</sup>	Max. power 35		Max. power 69		Max. power 67		
	Type	Non-magnetizing lock						
	Holding force [N]	*7	24	2.5	300	48	500	77
	Power [W] <sup>*8</sup>		3.5		2.9		5	
Rated voltage [V]		24 VDC ±10%						

\*1 Speed changes according to the work load. Check the "Speed-Work Load Graph (Guide)" on page 650.

\*2 Pushing force accuracy is ±20% (F.S.).

\*3 The speed and force may change depending on the cable length, load, and mounting conditions. Furthermore, if the cable length exceeds 5 m, then it will decrease by up to 10% for each 5 m. (At 15 m: Reduced by up to 20%)

\*4 A reference value for correcting errors in reciprocal operation

\*5 Vibration resistance: No malfunction occurred in a test ranging between 45 to 2000 Hz. The test was performed in both an axial direction and a perpendicular direction to the lead screw. (The test was performed with the actuator in the initial state.)

Impact resistance: No malfunction occurred when the actuator was tested with a drop tester in both an axial direction and a perpendicular direction to the lead screw. (The test was performed with the actuator in the initial state.)

\*6 Indicates the max. power during operation (including the controller)

This value can be used for the selection of the power supply.

\*7 With lock only

\*8 For an actuator with lock, add the power for the lock.

# LES Series

Incremental (Step Motor 24 VDC)

Incremental (Servo Motor 24 VDC)

## Specifications

### Servo Motor (24 VDC)

Model		LES8□A		LES16□A		LES25 <sup>R</sup> A*1		
Actuator specifications	Stroke [mm]	30, 50, 75		30, 50, 75, 100		30, 50, 75, 100, 125, 150		
	Work load [kg]	Horizontal		3		5		
		Vertical		1	0.5	3	1.5	4
	Pushing force 50 to 100% [N]*2	7.5 to 11	5 to 7.5	17.5 to 35	10 to 20	31 to 62	19 to 38	
	Speed [mm/s]	1 to 200	1 to 400	1 to 200	1 to 400	1 to 200	1 to 400	
	Pushing speed [mm/s]	1 to 20						
	Max. acceleration/deceleration [mm/s <sup>2</sup> ]	5000						
	Positioning repeatability [mm]	±0.05						
	Lost motion [mm]*3	0.3 or less						
	Screw lead [mm]	4	8	5	10	8	16	
	Impact/Vibration resistance [m/s <sup>2</sup> ]*4	50/20						
	Actuation type	Slide screw + Belt (R/L type), Slide screw (D type)						
	Guide type	Linear guide (Circulating type)						
	Operating temperature range [°C]	5 to 40						
Operating humidity range [%RH]	90 or less (No condensation)							
Enclosure	IP30							
Electric specifications	Motor size	□20		□28		□42		
	Motor output [W]	10		30		36		
	Motor type	Servo motor (24 VDC)						
	Encoder (Angular displacement sensor)	Incremental						
	Power supply voltage [V]	24 VDC ±10%						
Power [W]*5 *7	Max. power 71		Max. power 102		Max. power 111			
Lock unit specifications	Type	Non-magnetizing lock						
	Holding force [N]	24	2.5	300	48	500	77	
	Power consumption [W]*7 *6	3.5		2.9		5		
	Rated voltage [V]	24 VDC ±10%						

\*1 LES25DA is not available.

\*2 The pushing force values for LES8□A is 50 to 75%. Pushing force accuracy is ±20% (F.S.).

\*3 A reference value for correcting errors in reciprocal operation

\*4 Vibration resistance: No malfunction occurred in a test ranging between 45 to 2000 Hz. The test was performed in both an axial direction and a perpendicular direction to the lead screw. (The test was performed with the actuator in the initial state.)

Impact resistance: No malfunction occurred when the actuator was tested with a drop tester in both an axial direction and a perpendicular direction to the lead screw. (The test was performed with the actuator in the initial state.)

\*5 Indicates the max. power during operation (including the controller)

This value can be used for the selection of the power supply.

\*6 With lock only

\*7 For an actuator with lock, add the power consumption for the lock.

## Weight

### Step Motor (Servo/24 VDC), Servo Motor (24 VDC) Common

[kg]

Stroke [mm]		Without lock						With lock					
		30	50	75	100	125	150	30	50	75	100	125	150
Model	LES8 <sup>R</sup> (A)	0.45	0.54	0.59	—	—	—	—	—	0.66	—	—	—
	LES16 <sup>R</sup> (A)	0.91	1.00	1.16	1.24	—	—	—	—	1.29	1.37	—	—
	LES25 <sup>R</sup> (A)	1.81	2.07	2.41	3.21	3.44	3.68	—	2.34	2.68	3.48	3.71	3.95
	LES8D(A)	0.40	0.52	0.58	—	—	—	0.47	0.59	0.65	—	—	—
	LES16D(A)	0.77	0.90	1.11	1.20	—	—	0.90	1.03	1.25	1.33	—	—
	LES25D	1.82	2.05	2.35	3.07	3.27	3.47	2.08	2.31	2.61	3.33	3.53	3.74

**Construction: Basic Type/R Type, Symmetrical Type/L Type**

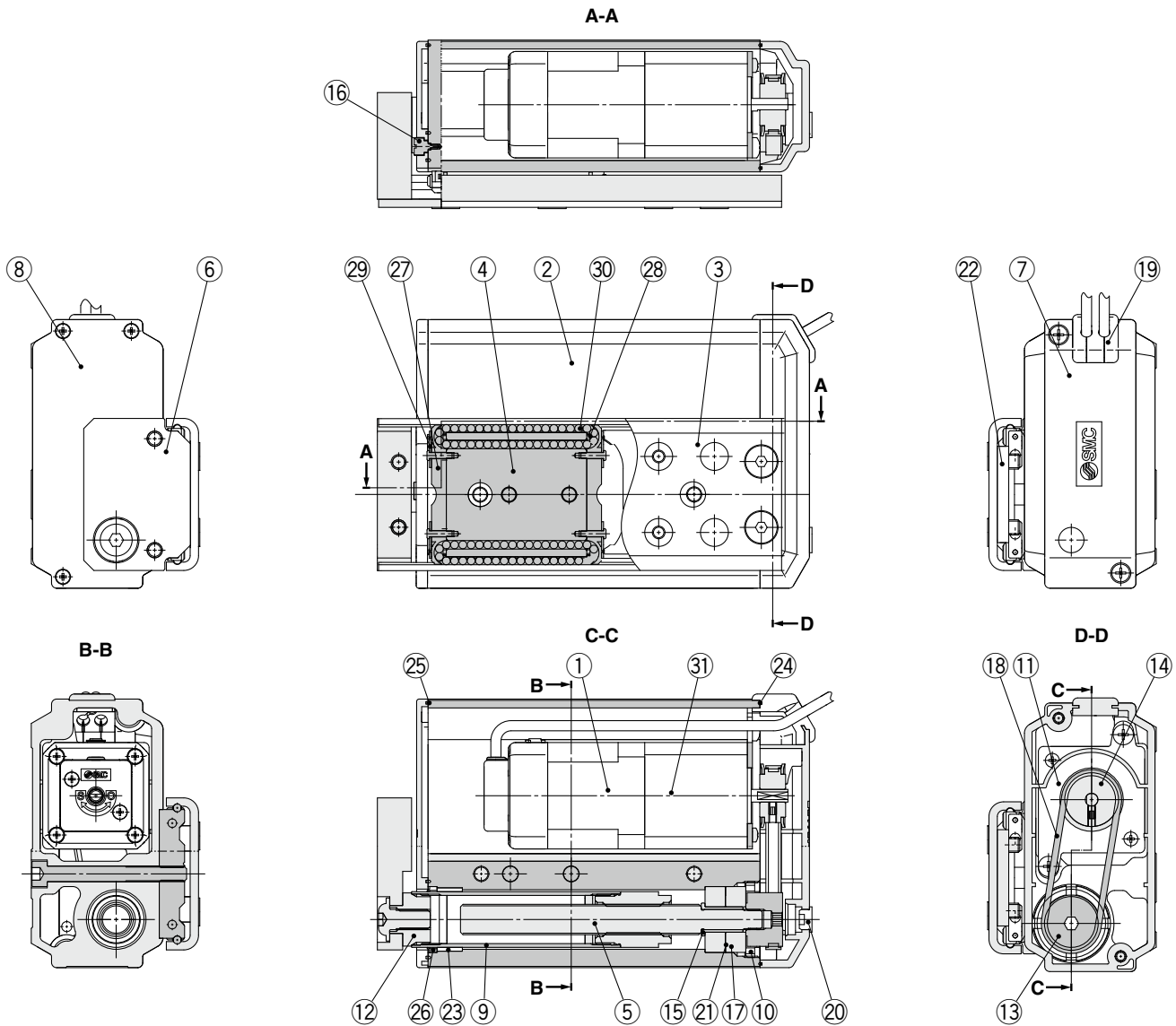

**Component Parts**

No.	Description	Material	Note
1	Motor	—	—
2	Body	Aluminum alloy	Anodized
3	Table	Stainless steel	Heat treatment + Electroless nickel plating
4	Guide block	Stainless steel	Heat treatment
5	Lead screw	Stainless steel	Heat treatment + Special treatment
6	End plate	Aluminum alloy	Anodized
7	Pulley cover	Synthetic resin	—
8	End cover	Synthetic resin	—
9	Rod	Stainless steel	—
10	Bearing stopper	Structural steel	Electroless nickel plating
		Brass	Electroless nickel plating (LES25R/L□ only)
11	Motor plate	Structural steel	—
12	Socket	Structural steel	Electroless nickel plating
13	Lead screw pulley	Aluminum alloy	—
14	Motor pulley	Aluminum alloy	—
15	Spacer	Stainless steel	LES25R/L□ only
16	Origin stopper	Structural steel	Electroless nickel plating
17	Bearing	—	—
18	Belt	—	—
19	Grommet	Synthetic resin	—
20	Cap	Silicone rubber	—
21	Sim ring	Structural steel	—

No.	Description	Material	Note
22	Stopper	Structural steel	—
23	Bushing	—	Dust-protected option only
24	Pulley gasket	NBR	Dust-protected option only
25	End gasket	NBR	Dust-protected option only
26	Scraper	NBR	Dust-protected option only
27	Cover	Synthetic resin	—
28	Return guide	Synthetic resin	—
29	Cover support	Stainless steel	—
30	Steel ball	Special steel	—
31	Lock	—	With lock only

**Replacement Parts/Belt**

Size	Order no.	Note
LES8□	LE-D-1-1	Without manual override screw
LES16□	LE-D-1-2	—
LES25□	LE-D-1-3	—
LES25□A	LE-D-1-4	—
LES8□	LE-D-1-5	With manual override screw

**Replacement Parts/Grease Pack**

Applied portion	Order no.
Guide unit	GR-S-010 (10 g) GR-S-020 (20 g)



# LES Series

Incremental (Step Motor 24 VDC)

Incremental (Servo Motor 24 VDC)

## Construction: In-line Motor Type/D Type

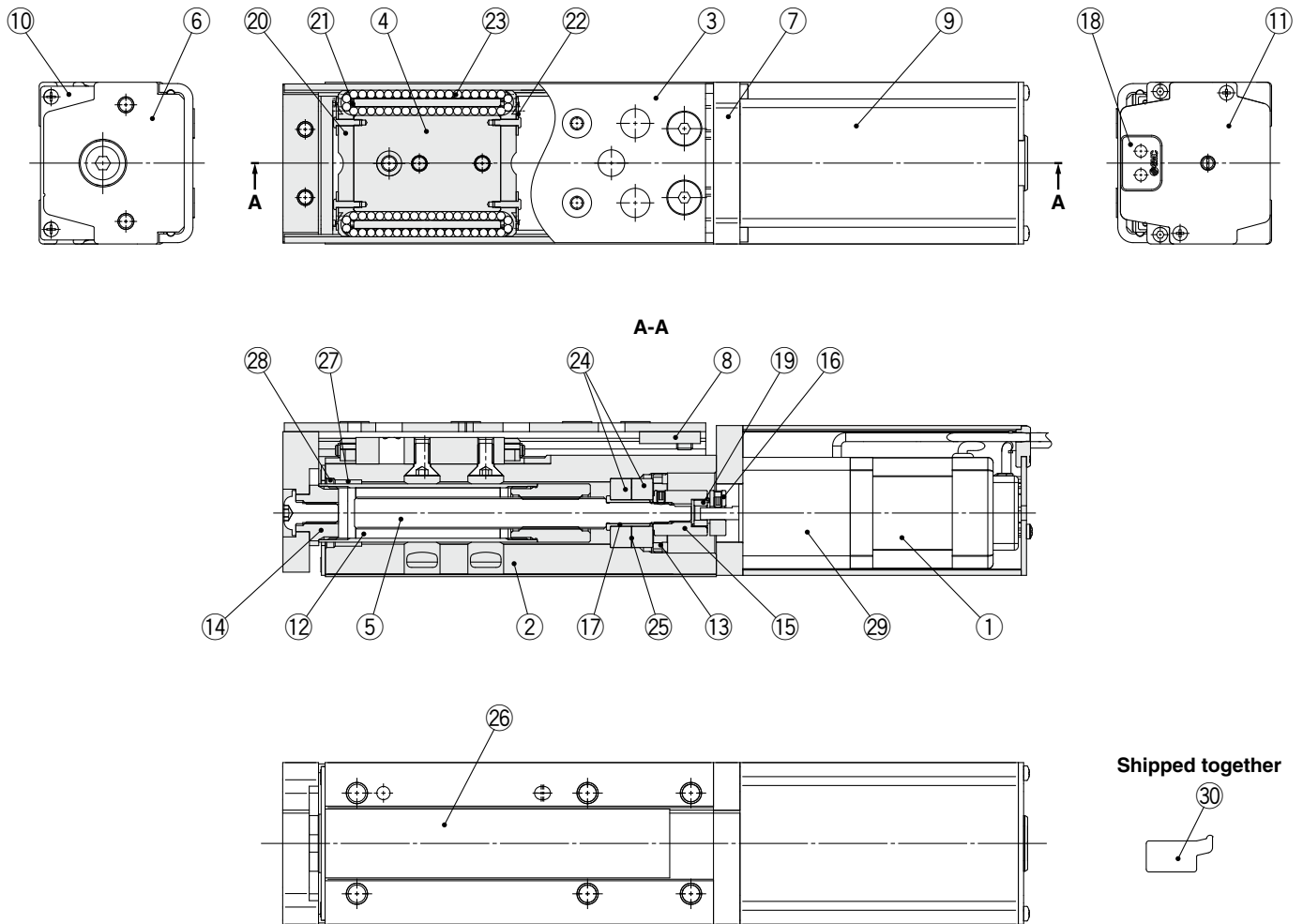

### Component Parts

No.	Description	Material	Note
1	Motor	—	—
2	Body	Aluminum alloy	Anodized
3	Table	Stainless steel	Heat treatment + Electroless nickel plating
4	Guide block	Stainless steel	Heat treatment
5	Lead screw	Stainless steel	Heat treatment + Special treatment
6	End plate	Aluminum alloy	Anodized
7	Motor flange	Aluminum alloy	Anodized
8	Stopper	Structural steel	—
9	Motor cover	Aluminum alloy	Anodized
10	End cover	Aluminum alloy	Anodized
11	Motor end cover	Aluminum alloy	Anodized
12	Rod	Stainless steel	—
13	Bearing stopper	Structural steel	Electroless nickel plating
		Brass	Electroless nickel plating (LES25D□ only)
14	Socket	Structural steel	Electroless nickel plating
15	Hub (Lead screw side)	Aluminum alloy	—
16	Hub (Motor side)	Aluminum alloy	—
17	Spacer	Stainless steel	LES25D□ only
18	Grommet	NBR	—
19	Spider	NBR	—
20	Cover	Synthetic resin	—

No.	Description	Material	Note
21	Return guide	Synthetic resin	—
22	Cover support	Stainless steel	—
23	Steel ball	Special steel	—
24	Bearing	—	—
25	Sim ring	Structural steel	—
26	Masking tape	—	—
27	Bushing	—	Dust-protected option only
28	Scraper	NBR	Dust-protected option only
29	Lock	—	With lock only
30	Side holder	Aluminum alloy	Anodized

### Optional Parts/Side Holder

Model	Order no.
LES8D	LE-D-3-1
LES16D	LE-D-3-2
LES25D	LE-D-3-3

### Replacement Parts/Grease Pack

Applied portion	Order no.
Guide unit	GR-S-010 (10 g) GR-S-020 (20 g)

**Dimensions: Basic Type/R Type**

**LES8R**

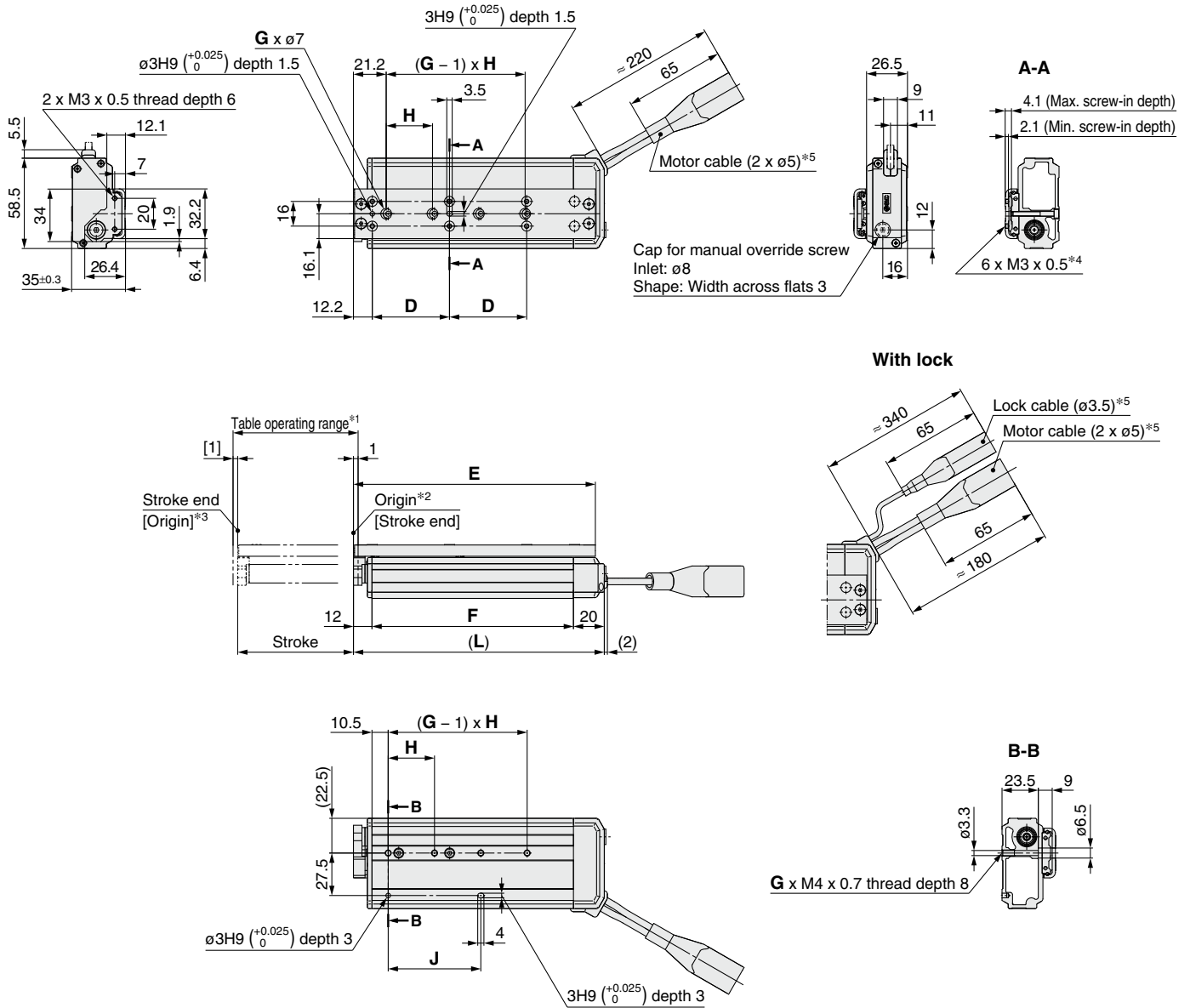

- \*1 This is the range within which the table can move when it returns to origin. Make sure that workpieces mounted on the table do not interfere with other workpieces or the facilities around the table.
- \*2 Position after returning to origin
- \*3 [ ] for when the direction of return to origin has changed
- \*4 If workpiece retaining screws are too long, they can touch the guide block and cause a malfunction. Use screws that are between the maximum and minimum screw-in depths in length.
- \*5 Secure the motor cable and lock cable so that the cables are not repeatedly bent.

Connector		
	Step motor	Servo motor
<b>Motor cable</b>		
<b>Lock cable</b>		

Dimensions	[mm]						
Model	L	D	E	F	G	H	J
LES8R□□-30□-□□□□□□	94.5	26	88.7	62.5	2	27	27
LES8R□□-50□-□□□□□□	137.5	46	131.7	105.5	3	29	58
LES8R□□-75□-□□□□□□	162.5	50	156.7	130.5	4	30	60

# LES Series

Incremental (Step Motor 24 VDC)

Incremental (Servo Motor 24 VDC)

## Dimensions: Basic Type/R Type



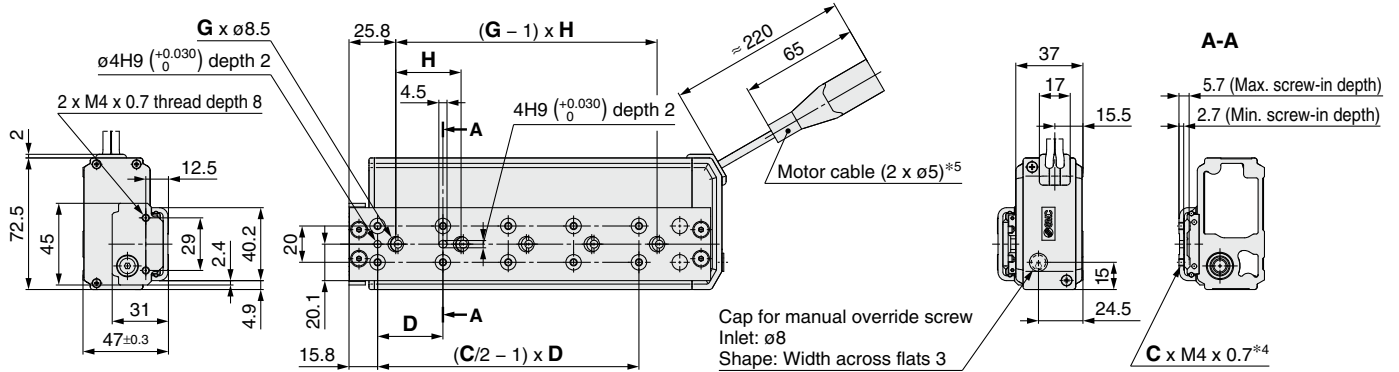

### LES16R

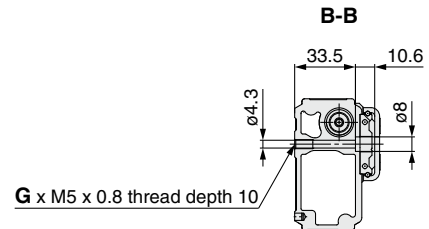
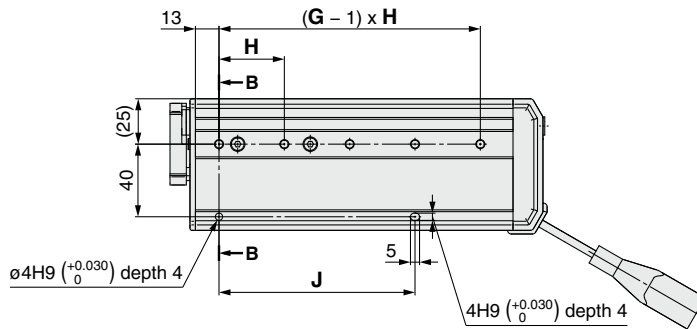
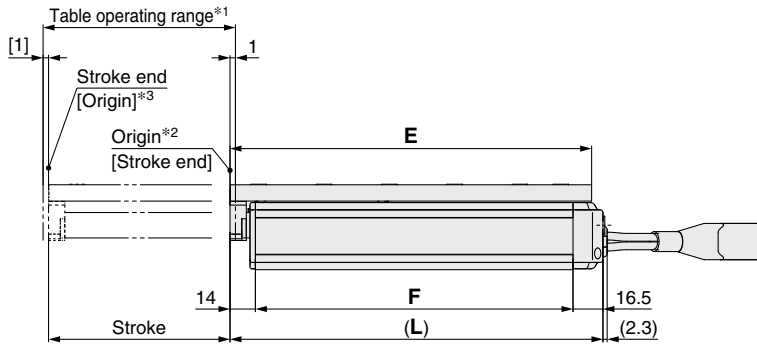
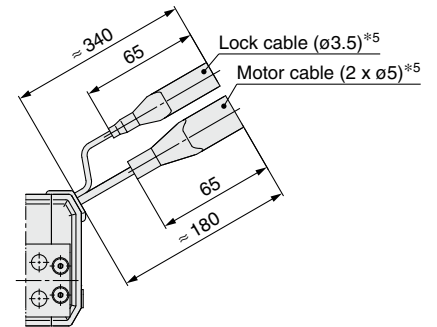

#### With lock



- \*1 This is the range within which the table can move when it returns to origin. Make sure that workpieces mounted on the table do not interfere with other workpieces or the facilities around the table.
- \*2 Position after returning to origin
- \*3 [ ] for when the direction of return to origin has changed
- \*4 If workpiece retaining screws are too long, they can touch the guide block and cause a malfunction. Use screws that are between the maximum and minimum screw-in depths in length.
- \*5 Secure the motor cable and lock cable so that the cables are not repeatedly bent.

	Connector	
	Step motor	Servo motor
Motor cable	 20	 24
Lock cable	 15	 15

### Dimensions

[mm]

Model	L	C	D	E	F	G	H	J
LES16R□□-30□-□□□□□□	108.5	4	38	102.3	78	2	40	40
LES16R□□-50□-□□□□□□	136.5	6	34	130.3	106	2	78	78
LES16R□□-75□-□□□□□□	180.5	8	36	174.3	150	4	36	72
LES16R□□-100□-□□□□□□	205.5	10	36	199.3	175	5	36	108

**Dimensions: Basic Type/R Type**  
**LES25R**

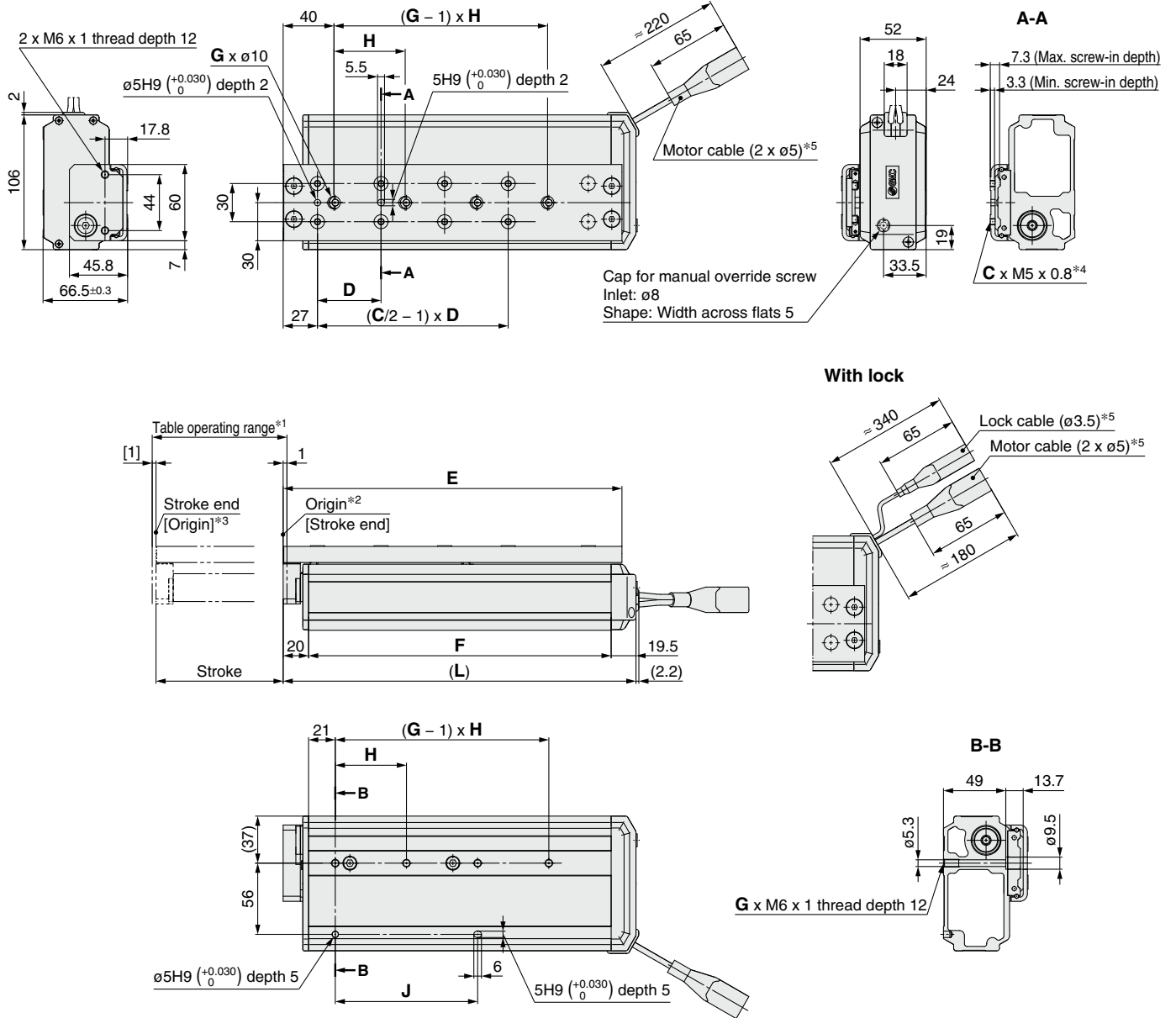

- \*1 This is the range within which the table can move when it returns to origin.  
Make sure that workpieces mounted on the table do not interfere with other workpieces or the facilities around the table.
- \*2 Position after returning to origin
- \*3 [ ] for when the direction of return to origin has changed
- \*4 If workpiece retaining screws are too long, they can touch the guide block and cause a malfunction.  
Use screws that are between the maximum and minimum screw-in depths in length.
- \*5 Secure the motor cable and lock cable so that the cables are not repeatedly bent.

**Dimensions**

Model	L	C	D	E	F	G	H	J
LES25R□□-30□□-□□□□□□	144.5	4	48	133.5	105	2	46	46
LES25R□□-50□□-□□□□□□	170.5	6	42	159.5	131	2	84	84
LES25R□□-75□□-□□□□□□	204.5	6	55	193.5	165	2	112	112
LES25R□□-100□□-□□□□□□	277.5	8	50	266.5	238	4	56	112
LES25R□□-125□□-□□□□□□	302.5	8	55	291.5	263	4	59	118
LES25R□□-150□□-□□□□□□	327.5	8	62	316.5	288	4	62	124

Connector		
	Step motor	Servo motor
Motor cable		
Lock cable		

# LES Series

Incremental (Step Motor 24 VDC)



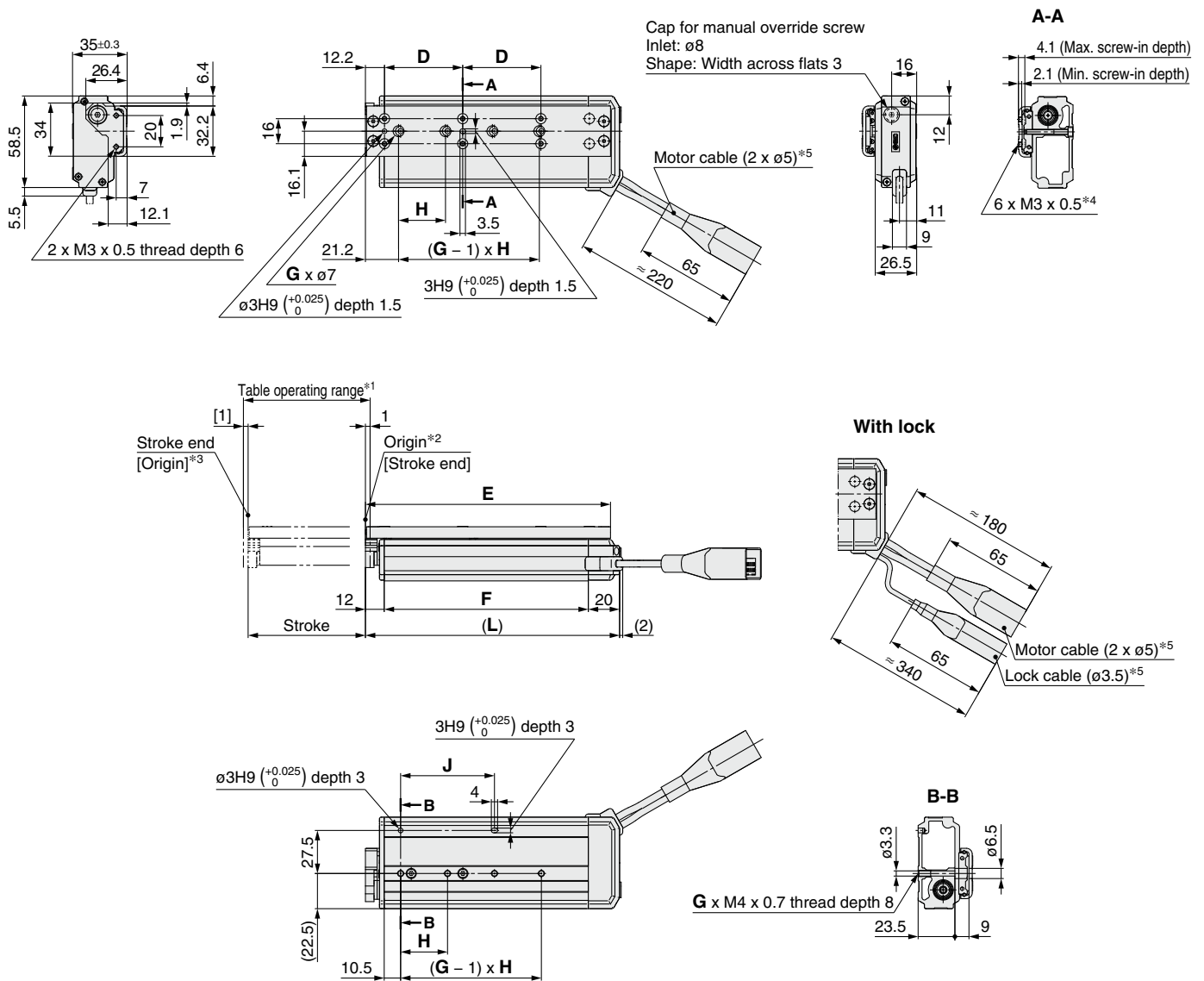

Incremental (Servo Motor 24 VDC)

## Dimensions: Symmetrical Type/L Type

### LES8L



- \*1 This is the range within which the table can move when it returns to origin. Make sure that workpieces mounted on the table do not interfere with other workpieces or the facilities around the table.
- \*2 Position after returning to origin
- \*3 [ ] for when the direction of return to origin has changed
- \*4 If workpiece retaining screws are too long, they can touch the guide block and cause a malfunction. Use screws that are between the maximum and minimum screw-in depths in length.
- \*5 Secure the motor cable and lock cable so that the cables are not repeatedly bent.

	Connector	
	Step motor	Servo motor
Motor cable		
Lock cable		

Dimensions	[mm]						
Model	L	D	E	F	G	H	J
LES8L□□-30□-□□□□□□	94.5	26	88.7	62.5	2	27	27
LES8L□□-50□-□□□□□□	137.5	46	131.7	105.5	3	29	58
LES8L□□-75□-□□□□□□	162.5	50	156.7	130.5	4	30	60

**Dimensions: Symmetrical Type/L Type**

**LES16L**

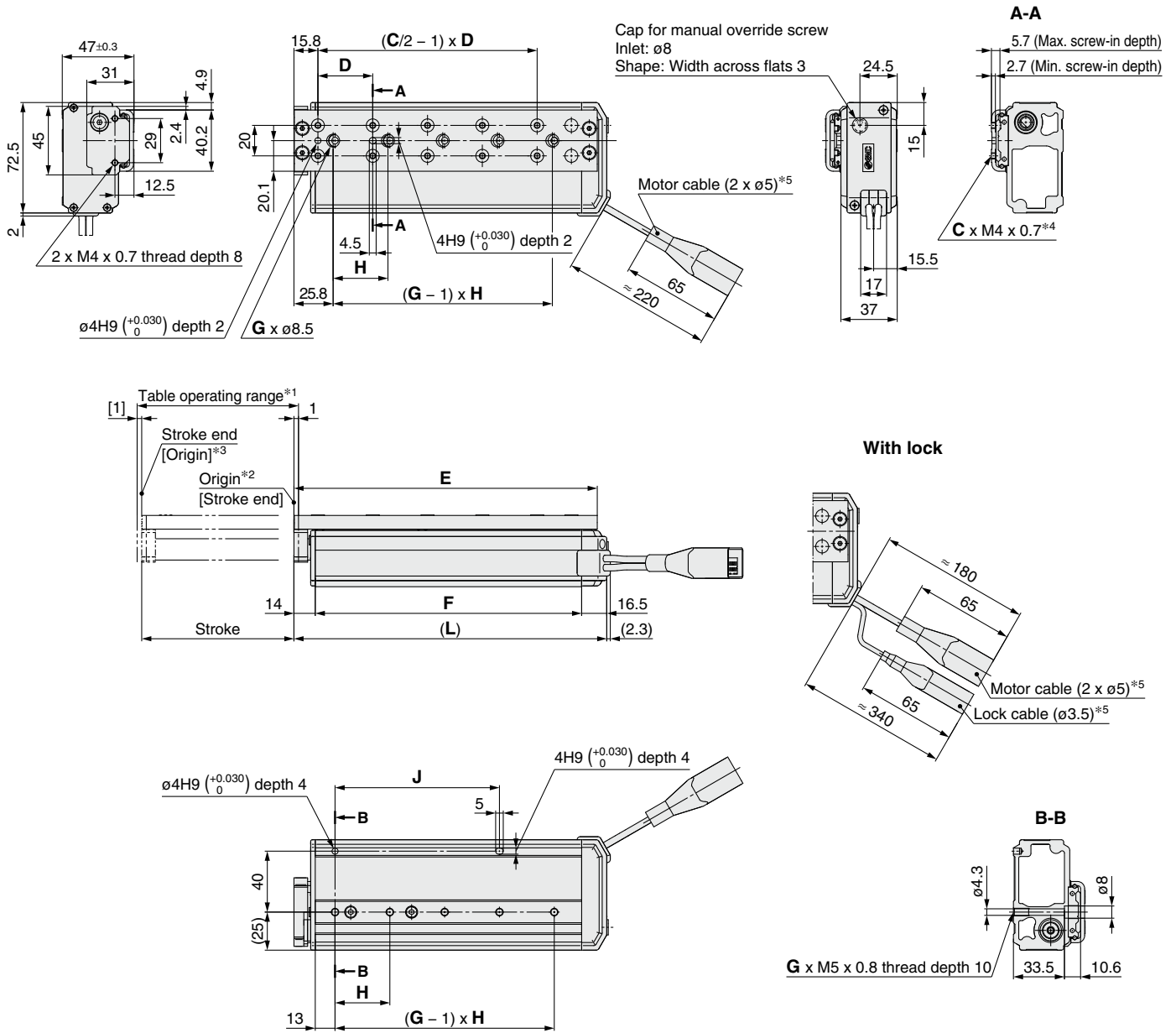

- \*1 This is the range within which the table can move when it returns to origin.  
 Make sure that workpieces mounted on the table do not interfere with other workpieces or the facilities around the table.
- \*2 Position after returning to origin
- \*3 [ ] for when the direction of return to origin has changed
- \*4 If workpiece retaining screws are too long, they can touch the guide block and cause a malfunction.  
 Use screws that are between the maximum and minimum screw-in depths in length.
- \*5 Secure the motor cable and lock cable so that the cables are not repeatedly bent.

	Connector	
	Step motor	Servo motor
Motor cable		
Lock cable		

Dimensions	[mm]							
Model	L	C	D	E	F	G	H	J
LES16L□□-30□-□□□□□□	108.5	4	38	102.3	78	2	40	40
LES16L□□-50□-□□□□□□	136.5	6	34	130.3	106	2	78	78
LES16L□□-75□-□□□□□□	180.5	8	36	174.3	150	4	36	72
LES16L□□-100□-□□□□□□	205.5	10	36	199.3	175	5	36	108

# LES Series

Incremental (Step Motor 24 VDC)

Incremental (Servo Motor 24 VDC)

## Dimensions: Symmetrical Type/L Type

### LES25L

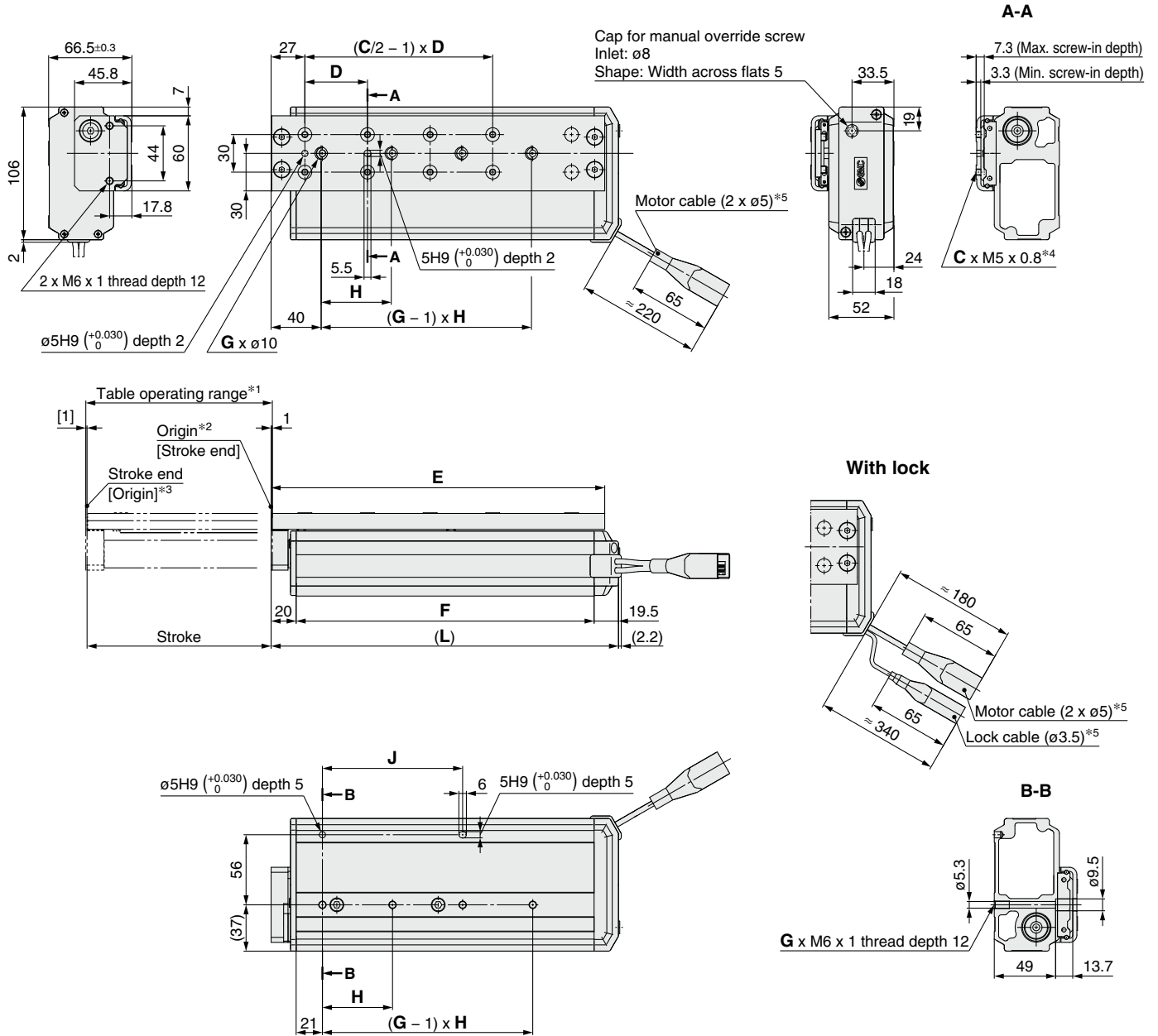

- \*1 This is the range within which the table can move when it returns to origin.  
Make sure that workpieces mounted on the table do not interfere with other workpieces or the facilities around the table.
- \*2 Position after returning to origin
- \*3 [ ] for when the direction of return to origin has changed
- \*4 If workpiece retaining screws are too long, they can touch the guide block and cause a malfunction.  
Use screws that are between the maximum and minimum screw-in depths in length.
- \*5 Secure the motor cable and lock cable so that the cables are not repeatedly bent.

### Dimensions

[mm]

Model	L	C	D	E	F	G	H	J
LES25L□□-30□-□□□□□□	144.5	4	48	133.5	105	2	46	46
LES25L□□-50□-□□□□□□	170.5	6	42	159.5	131	2	84	84
LES25L□□-75□-□□□□□□	204.5	6	55	193.5	165	2	112	112
LES25L□□-100□-□□□□□□	277.5	8	50	266.5	238	4	56	112
LES25L□□-125□-□□□□□□	302.5	8	55	291.5	263	4	59	118
LES25L□□-150□-□□□□□□	327.5	8	62	316.5	288	4	62	124

	Connector	
	Step motor	Servo motor
Motor cable		
Lock cable		

## Dimensions: In-line Motor Type/D Type

### LES8D

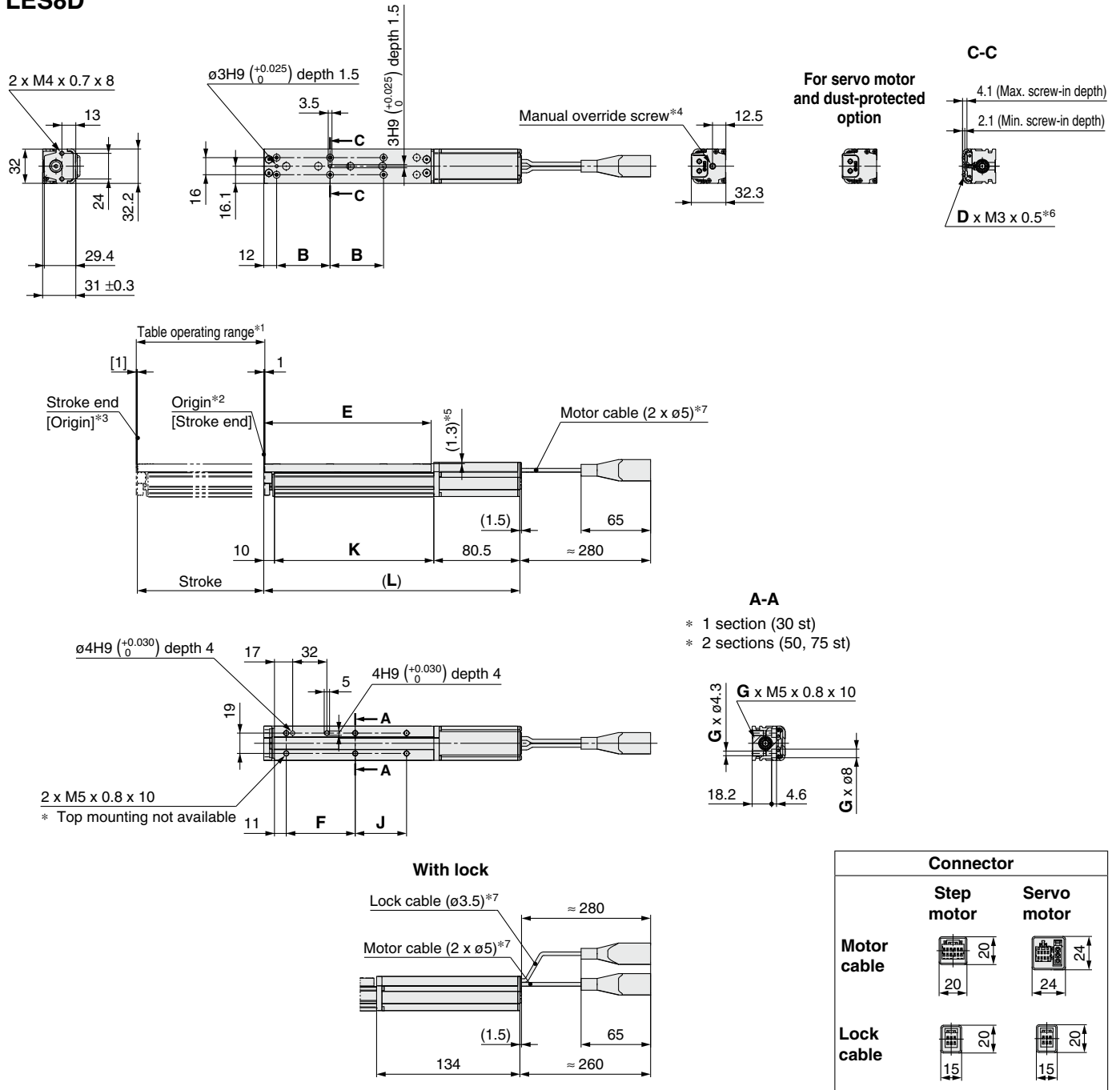

- \*1 This is the range within which the table can move when it returns to origin.  
 Make sure that workpieces mounted on the table do not interfere with other workpieces or the facilities around the table.
- \*2 Position after returning to origin
- \*3 [ ] for when the direction of return to origin has changed
- \*4 The distance between the motor end cover and the manual override screw is up to 16 mm. The motor end cover hole size is ø5.5.
- \*5 The table is lower than the motor cover. Make sure it does not interfere with the workpiece.
- \*6 If workpiece retaining screws are too long, they can touch the guide block and cause a malfunction.  
 Use screws that are between the maximum and minimum screw-in depths in length.
- \*7 Secure the motor cable and lock cable so that the cables are not repeatedly bent.

### Dimensions

Model	(L)	B	D	E	F	G	J	K
LES8D□□-30□□-□□□□□□	171.5	26	6	88.5	44.5	2	—	81
LES8D□□-30B□□-□□□□□□	225							
LES8D□□-50□□-□□□□□□	214.5	46	6	131.5	64.5	4	23	124
LES8D□□-50B□□-□□□□□□	268							
LES8D□□-75□□-□□□□□□	239.5	50	6	156.5	64.5	4	48	149
LES8D□□-75B□□-□□□□□□	293							



# LES Series

Incremental (Step Motor 24 VDC)

Incremental (Servo Motor 24 VDC)

## Dimensions: In-line Motor Type/D Type

### LES16D

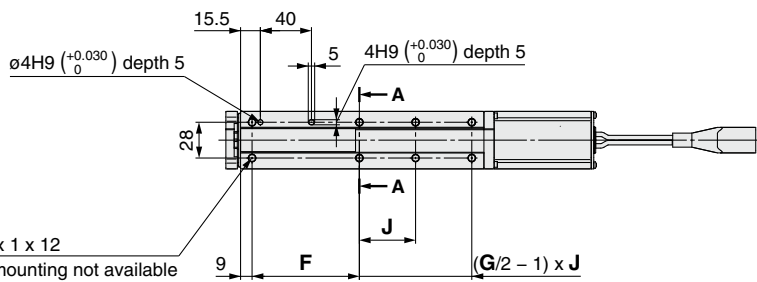
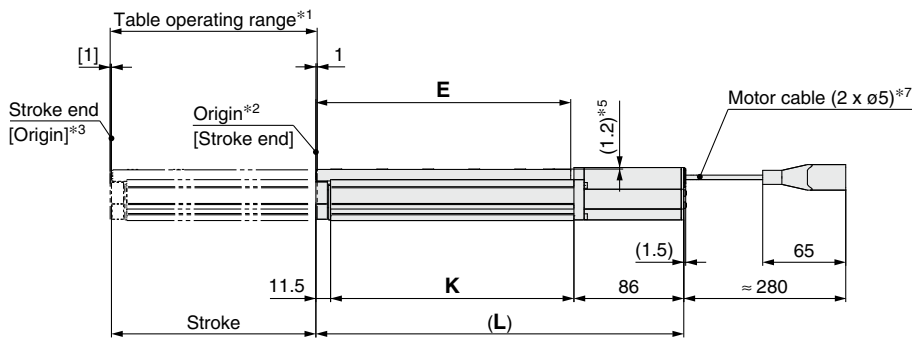
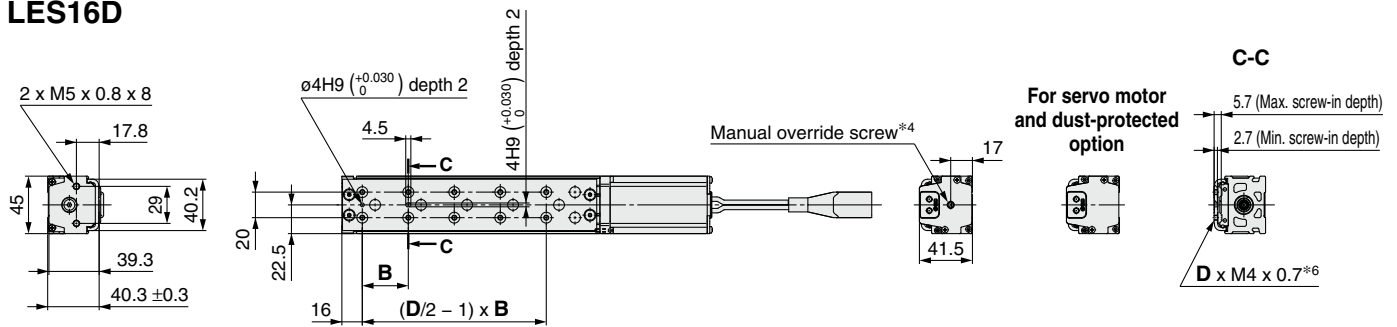



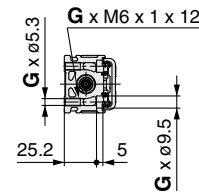

#### A-A

- \* 2 sections (30, 50, 75 st)
- \* 3 sections (100 st)

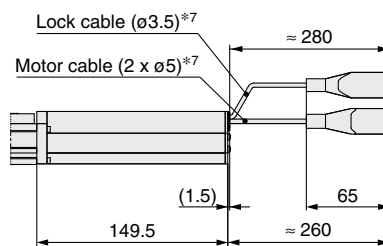

#### With lock



	Connector	
	Step motor	Servo motor
Motor cable	 20 20	 24 24
Lock cable	 20 15	 20 15

- \*1 This is the range within which the table can move when it returns to origin. Make sure that workpieces mounted on the table do not interfere with other workpieces or the facilities around the table.
- \*2 Position after returning to origin
- \*3 [ ] for when the direction of return to origin has changed
- \*4 The distance between the motor end cover and the manual override screw is up to 17 mm. The motor end cover hole size is ø5.5.
- \*5 The table is lower than the motor cover. Make sure it does not interfere with the workpiece.
- \*6 If workpiece retaining screws are too long, they can touch the guide block and cause a malfunction. Use screws that are between the maximum and minimum screw-in depths in length.
- \*7 Secure the motor cable and lock cable so that the cables are not repeatedly bent.

### Dimensions

[mm]

Model	(L)	B	D	E	F	G	J	K
LES16D□□-30□□-□□□□□□	193	38	4	102.5	56.5	4	18.5	95.5
LES16D□□-30B□□-□□□□□□	256.5	38	4	102.5	56.5	4	18.5	95.5
LES16D□□-50□□-□□□□□□	221	34	6	130.5	65	4	38	123.5
LES16D□□-50B□□-□□□□□□	284.5	34	6	130.5	65	4	38	123.5
LES16D□□-75□□-□□□□□□	265	36	8	174.5	84	4	63	167.5
LES16D□□-75B□□-□□□□□□	328.5	36	8	174.5	84	4	63	167.5
LES16D□□-100□□-□□□□□□	290	36	10	199.5	84	6	44	192.5
LES16D□□-100B□□-□□□□□□	353.5	36	10	199.5	84	6	44	192.5

## Dimensions: In-line Motor Type/D Type

### LES25D

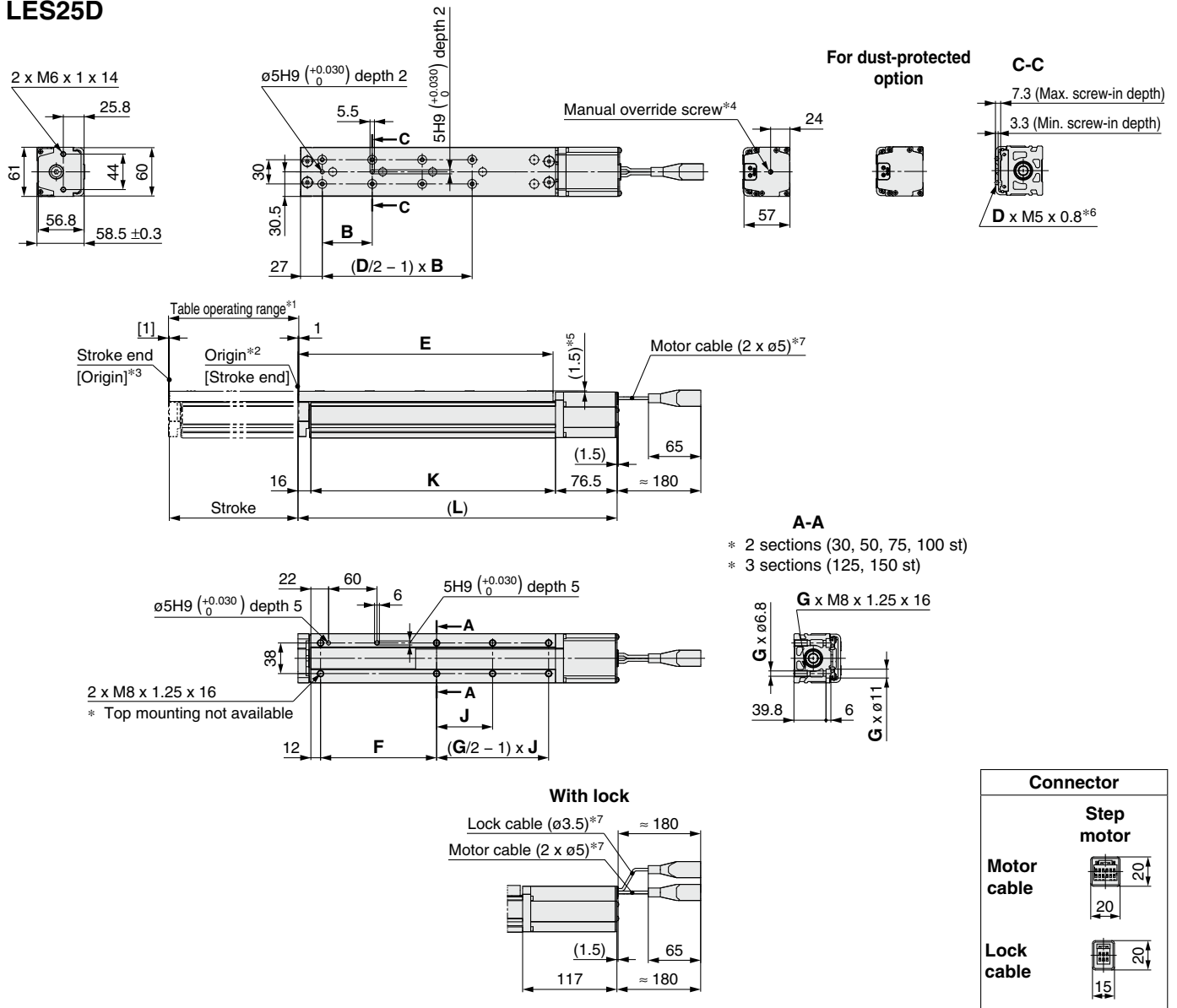

- \*1 This is the range within which the table can move when it returns to origin. Make sure that workpieces mounted on the table do not interfere with other workpieces or the facilities around the table.
- \*2 Position after returning to origin
- \*3 [ ] for when the direction of return to origin has changed
- \*4 The distance between the motor end cover and the manual override screw is up to 4 mm. The motor end cover hole size is ø5.5.
- \*5 The table is lower than the motor cover.
- \*6 If workpiece retaining screws are too long, they can touch the guide block and cause a malfunction. Use screws that are between the maximum and minimum screw-in depths in length.
- \*7 Secure the motor cable and lock cable so that the cables are not repeatedly bent.

### Dimensions

Model	(L)	B	D	E	F	G	J	K
LES25D-30□□-□□□□□□	214	48	4	133.5	81	4	19	121.5
LES25D-30B□□-□□□□□□	254.5							
LES25D-50□□-□□□□□□	240	42	6	159.5	87	4	39	147.5
LES25D-50B□□-□□□□□□	280.5							
LES25D-75□□-□□□□□□	274	55	6	193.5	96	4	64	181.5
LES25D-75B□□-□□□□□□	314.5							
LES25D-100□□-□□□□□□	347	50	8	266.5	144	4	89	254.5
LES25D-100B□□-□□□□□□	387.5							
LES25D-125□□-□□□□□□	372	55	8	291.5	144	6	57	279.5
LES25D-125B□□-□□□□□□	412.5							
LES25D-150□□-□□□□□□	397	62	8	316.5	144	6	69.5	304.5
LES25D-150B□□-□□□□□□	437.5							

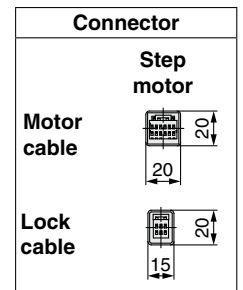

# LES Series

Incremental (Step Motor 24 VDC)

Incremental (Servo Motor 24 VDC)

## Side Holder (In-line Motor Type/D Type)

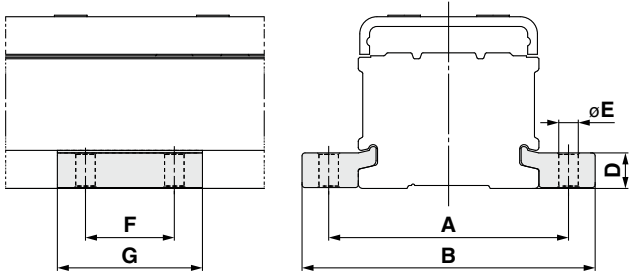

Part no.*1	A	B	D	E	F	G	Applicable model
LE-D-3-1	45	57.6	6.7	4.5	20	33	LES8D
LE-D-3-2	60	74	8.3	5.5	25	40	LES16D
LE-D-3-3	81	99	12	6.6	30	49	LES25D

\*1 Part numbers for 1 side holder



# Model Selection 1



LESH□E Series ▶ p. 705

## Selection Procedure

For the compact type LES series, refer to page 641.



### Selection Example

**Step 1 Check the work load-speed.** <Speed-Work load graph> (page 688)  
 Select a model based on the workpiece mass and speed while referencing the speed-work load graph.  
 Selection example) The LESH25□EJ-50 can be temporarily selected as a possible candidate based on the graph shown on the right side.

**Step 2 Check the cycle time.**  
 It is possible to find an approximate cycle time by using method 1, but if a more detailed cycle time is required, use method 2.

\* Although it is possible to make a suitable selection by using method 1, this calculation is based on a maximum load condition. Therefore, if a more detailed selection for each load is required, use method 2.

### Operating conditions

- Workpiece mass: 2 [kg]
- Workpiece mounting condition:
- Speed: 200 [mm/s]
- Mounting orientation: Vertical
- Stroke: 50 [mm]
- Acceleration/Deceleration: 5000 [mm/s<sup>2</sup>]
- Cycle time: 0.5 s

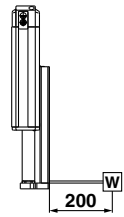

#### Method 1: Check the cycle time graph. (page 688)

#### Method 2: Calculation <Speed-Work load graph> (page 688)

Calculate the cycle time using the following calculation method.

#### Cycle time:

T can be found from the following equation.

$$T = T1 + T2 + T3 + T4 \text{ [s]}$$

- T1: Acceleration time and T3: Deceleration time can be found by the following equation.

$$T1 = V/a1 \text{ [s]} \quad T3 = V/a2 \text{ [s]}$$

- T2: Constant speed time can be found from the following equation.

$$T2 = \frac{L - 0.5 \cdot V \cdot (T1 + T3)}{V} \text{ [s]}$$

- T4: Settling time varies depending on the conditions such as motor types, load, and in position of the step data. Therefore, calculate the settling time while referencing the following value.

$$T4 = 0.15 \text{ [s]}$$

Calculation example

T1 to T4 can be calculated as follows.

$$T1 = V/a1 = 200/5000 = 0.04 \text{ [s]}$$

$$T3 = V/a2 = 200/5000 = 0.04 \text{ [s]}$$

$$T2 = \frac{L - 0.5 \cdot V \cdot (T1 + T3)}{V} = \frac{50 - 0.5 \cdot 200 \cdot (0.04 + 0.04)}{200} = 0.21 \text{ [s]}$$

$$T4 = 0.15 \text{ [s]}$$

The cycle time can be found as follows.

$$T = T1 + T2 + T3 + T4 = 0.04 + 0.21 + 0.04 + 0.15 = 0.44 \text{ [s]}$$

### LESH25□E□/Battery-less Absolute Vertical

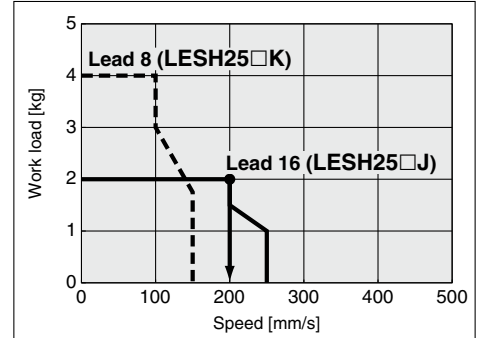

<Speed-Work load graph>

### LESH25□/Battery-less Absolute Pitching

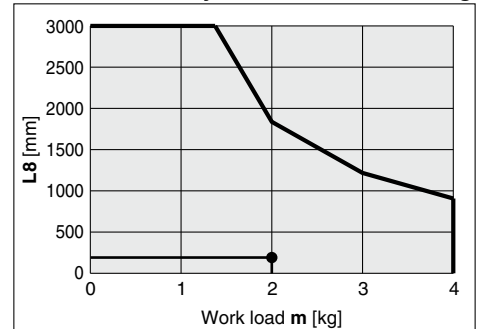

<Dynamic allowable moment>

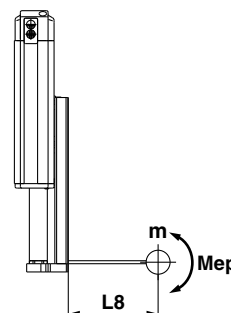

**Step 3 Check the allowable moment.** <Static allowable moment> (page 688)  
 <Dynamic allowable moment> (page 689)

Confirm the moment that applies to the actuator is within the allowable range for both static and dynamic conditions.

Based on the above calculation result, the LESH25□EJ-50 should be selected.

## Speed-Work Load Graph (Guide)

### Battery-less Absolute (Step Motor 24 VDC)

\* The following graphs show the values when the moving force is 100%.

#### LESH25□E□

##### Horizontal

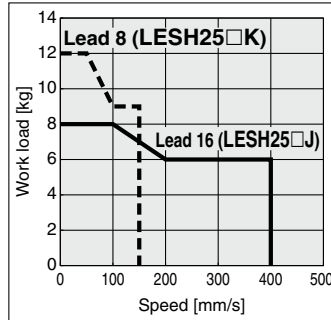

##### Vertical

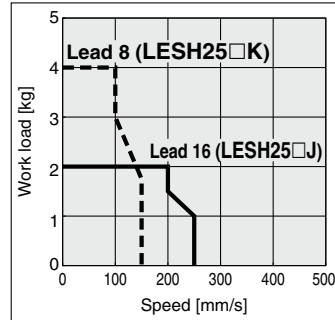

## Cycle Time Graph (Guide)

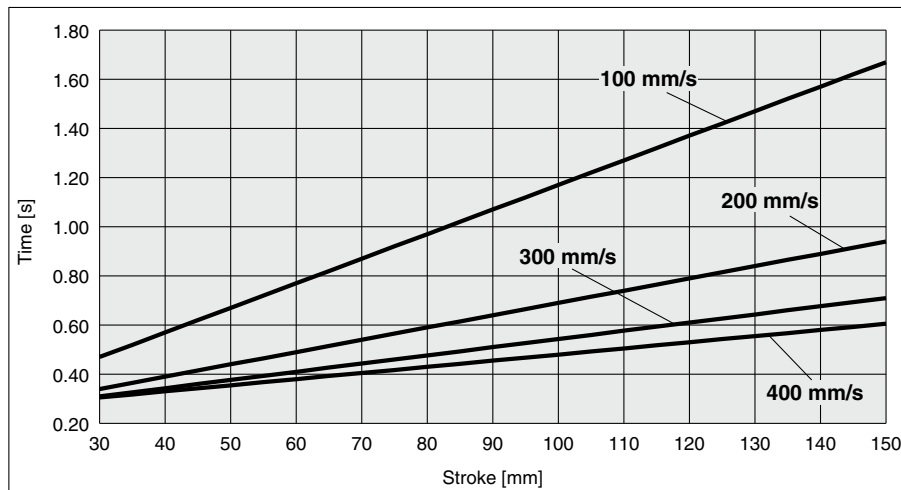

### Operating Conditions

Acceleration/Deceleration: 5000 mm/s<sup>2</sup>

In position: 0.5 mm

## Static Allowable Moment

Model		LESH25		
Stroke	[mm]	50	100	150
Pitching	[N·m]	77	112	155
Yawing	[N·m]			
Rolling	[N·m]	146	177	152

# LESH Series

Battery-less Absolute (Step Motor 24 VDC)

\* These graphs show the amount of allowable overhang (guide unit) when the center of gravity of the workpiece overhangs in one direction. When selecting the overhang, refer to the "Calculation of Guide Load Factor" or the Electric Actuator Model Selection Software for confirmation: <https://www.smcworld.com>

## Dynamic Allowable Moment

Acceleration/Deceleration — 5000 mm/s<sup>2</sup>

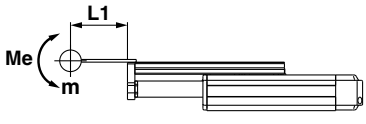
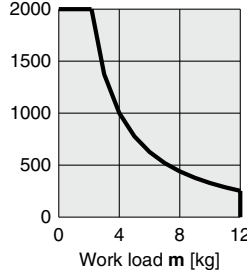
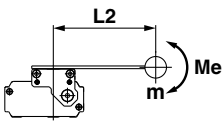
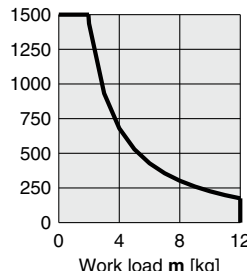
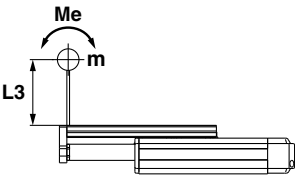
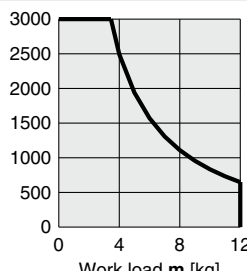
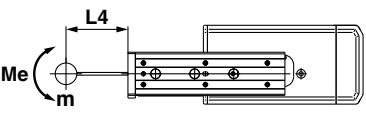
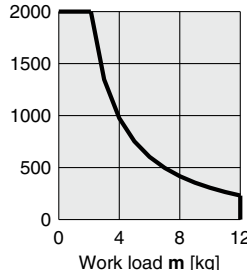
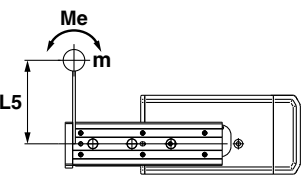
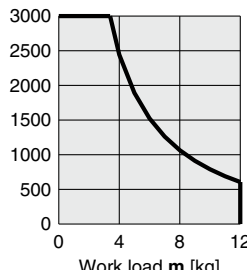
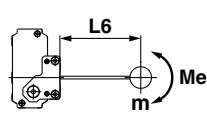
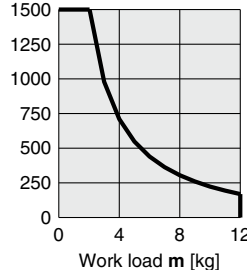
Orientation	Load overhanging direction m : Work load [kg] Me: Allowable moment [N·m] L : Overhang to the work load center of gravity [mm]	Model	
		LESH25	
Horizontal/Bottom		X	
		Y	
		Z	
Horizontal (Wall)		X	
		Y	
		Z	

\* These graphs show the amount of allowable overhang (guide unit) when the center of gravity of the workpiece overhangs in one direction. When selecting the overhang, refer to the "Calculation of Guide Load Factor" or the Electric Actuator Model Selection Software for confirmation: <https://www.smcworld.com>

## Dynamic Allowable Moment

Acceleration/Deceleration — 5000 mm/s<sup>2</sup>

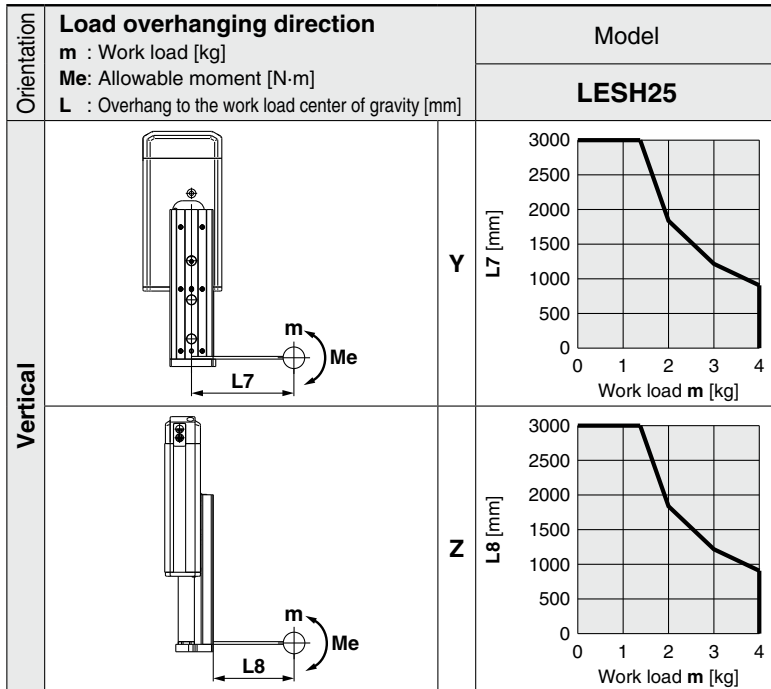

## Calculation of Guide Load Factor

- Decide operating conditions.

Model: LESH

Size: 25

Mounting orientation: Horizontal/Bottom/Wall/Vertical

Acceleration [mm/s<sup>2</sup>]: a

Work load [kg]: m

Work load center position [mm]: Xc/Yc/Zc

- Select the target graph while referencing the model, size, and mounting orientation.

- Based on the acceleration and work load, find the overhang [mm]: Lx/Ly/Lz from the graph.

- Calculate the load factor for each direction.

$$\alpha x = Xc/Lx, \alpha y = Yc/Ly, \alpha z = Zc/Lz$$

- Confirm the total of  $\alpha x$ ,  $\alpha y$ , and  $\alpha z$  is 1 or less.

$$\alpha x + \alpha y + \alpha z \leq 1$$

When 1 is exceeded, please consider a reduction of acceleration and work load, or a change of the work load center position and series.

### Mounting orientation

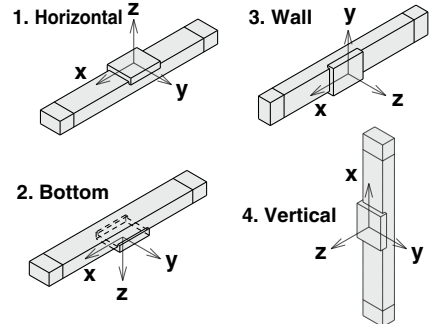

### Example

- Operating conditions

Model: LESH

Size: 25

Mounting orientation: Horizontal

Acceleration [mm/s<sup>2</sup>]: 5000

Work load [kg]: 4.0

Work load center position [mm]: Xc = 250, Yc = 250, Zc = 500

- Select three graphs from the top on page 689.

- Lx = 1000 mm, Ly = 650 mm, Lz = 2500 mm

- The load factor for each direction can be found as follows.

$$\alpha x = 250/1000 = 0.25$$

$$\alpha y = 250/650 = 0.38$$

$$\alpha z = 500/2500 = 0.20$$

- $\alpha x + \alpha y + \alpha z = 0.83 \leq 1$

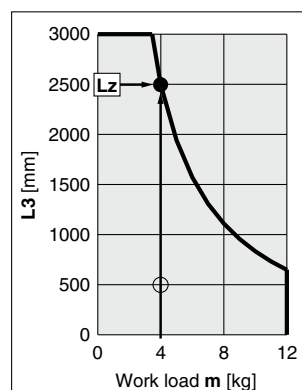
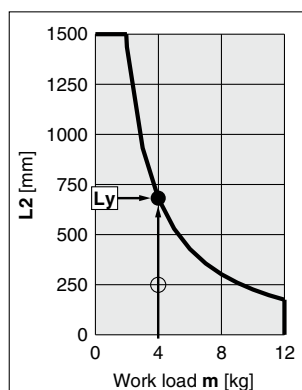
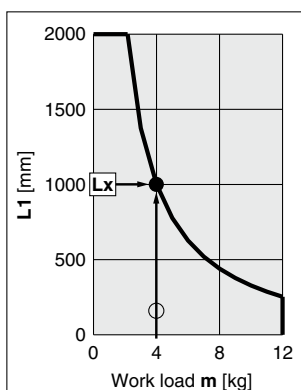



# Model Selection 2



## Selection Procedure For the compact type LES series, refer to page 645.

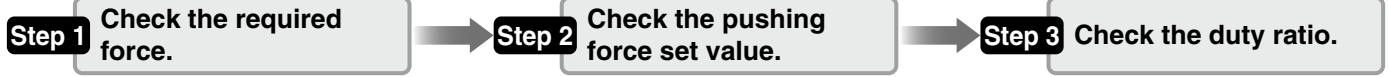

### Selection Example

#### Operating conditions

- Pushing force: 90 [N]
- Workpiece mass: 1 [kg]
- Speed: 100 [mm/s]
- Stroke: 100 [mm]
- Mounting orientation: Vertical upward
- Pushing time + Operation (A): 1.5 s
- Full cycle time (B): 6 s

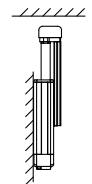

#### Step 1 Check the required force.

Calculate the approximate required force for a pushing operation.

Selection example) • Pushing force: 90 [N]  
 • Workpiece mass: 1 [kg]  
 The approximate required force can be found to be  $90 + 10 = 100$  [N].

Select a model based on the approximate required force while referencing the specifications (page 707).

Selection example) Based on the specifications,  
 • Approximate required force: 100 [N]  
 • Speed: 100 [mm/s]  
 The LESH25□E can be temporarily selected as a possible candidate.

Then, calculate the required force for a pushing operation. If the mounting position is vertical upward, add the actuator table weight.

Selection example) Based on the table weight,  
 • LESH25□E table weight: 1.3 [kg]  
 The required force can be found to be  $100 + 13 = 113$  [N].

#### Step 2 Check the pushing force set value.

<Pushing force set value–Force graph> (page 692)

Select a model based on the required force while referencing the pushing force set value–force graph, and confirm the pushing force set value.

Selection example) Based on the graph shown on the right side,  
 • Required force: 113 [N]  
 The LESH25□EK can be temporarily selected as a possible candidate.  
 This pushing force set value is 40 [%].

#### Step 3 Check the duty ratio.

Confirm the allowable duty ratio based on the pushing force set value while referencing the allowable duty ratio,

Selection example) Based on the allowable duty ratio,  
 • Pushing force set value: 40 [%]  
 The allowable duty ratio can be found to be 30 [%].

Calculate the duty ratio for the operating conditions, and confirm it does not exceed the allowable duty ratio.

Selection example) • Pushing time + Operation (A): 1.5 s  
 • Full cycle time (B): 6 s  
 The duty ratio can be found to be  $1.5/6 \times 100 = 25$  [%], and this is within the allowable range.

#### Table Weight

[kg]

Model	Stroke [mm]			
	50	75	100	150
LESH25	0.9	—	1.3	1.7

\* If the mounting position is vertical upward, add the table weight.

#### LESH25□E□/Battery-less Absolute

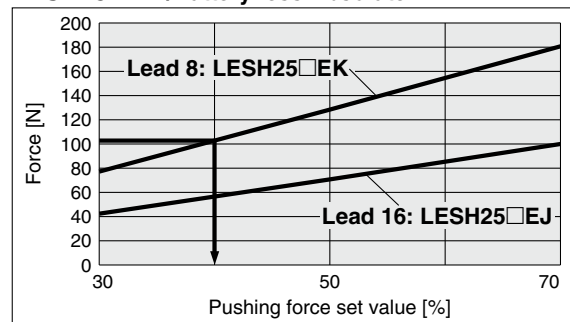

<Pushing force set value–Force graph>

#### Allowable Duty Ratio

##### Battery-less Absolute

Pushing force set value [%]	Duty ratio [%]	Continuous pushing time [min]
30	—	—
50 or less	30 or less	5 or less
70 or less	20 or less	3 or less

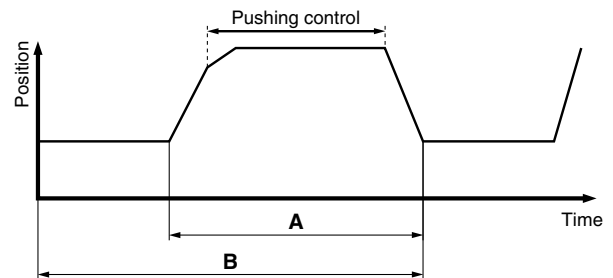

Based on the above calculation result, the LESH25□EK-100 should be selected.

For allowable moment, the selection procedure is the same as that for the positioning control.

## Pushing Force Set Value–Force Graph

Battery-less Absolute (Step Motor 24 VDC)

### LESH25□E□

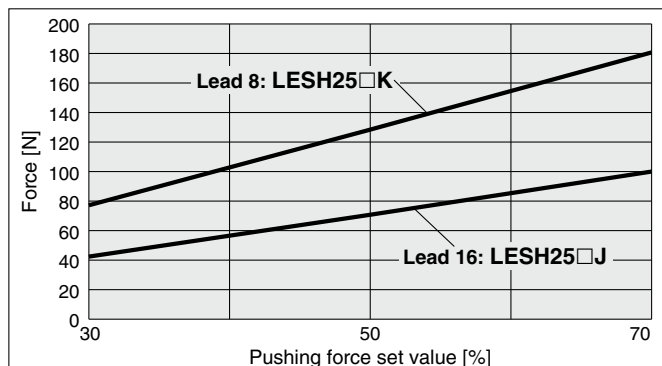

## Table Accuracy

\* These values are initial guideline values.

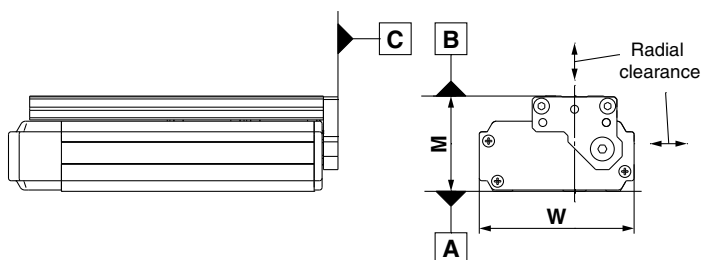

Model	LESH25
B side parallelism to A side [mm]	Refer to Table 1.
B side traveling parallelism to A side [mm]	Refer to Graph 1.
C side perpendicularity to A side [mm]	0.05
M dimension tolerance [mm]	±0.3
W dimension tolerance [mm]	±0.2
Radial clearance [μm]	-14 to 0

**Table 1** B side parallelism to A side

Model	Stroke [mm]			
	50	75	100	150
<b>LESH25</b>	0.06	—	0.08	0.125

**Graph 1** B side traveling parallelism to A side

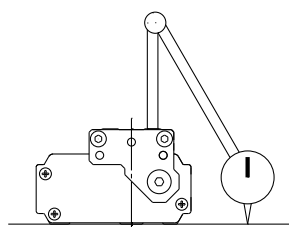
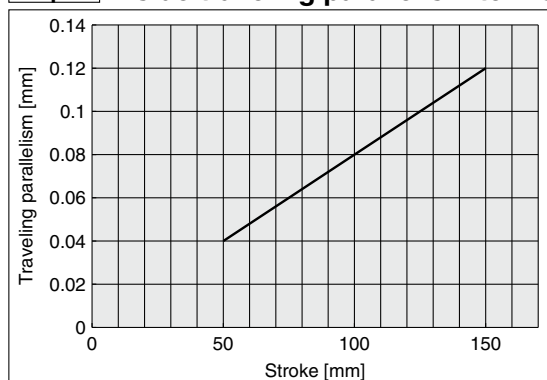

**Traveling parallelism:**  
The amount of deflection on a dial gauge when the table travels a full stroke with the body secured on a reference base surface

# LESH Series

Battery-less Absolute (Step Motor 24 VDC)

## Table Deflection (Reference Value)

\* These values are initial guideline values.

Table displacement due to pitch moment load  
Table displacement when loads are applied to the section marked with the arrow with the slide table stuck out.

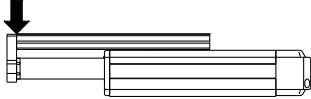

### LESH25

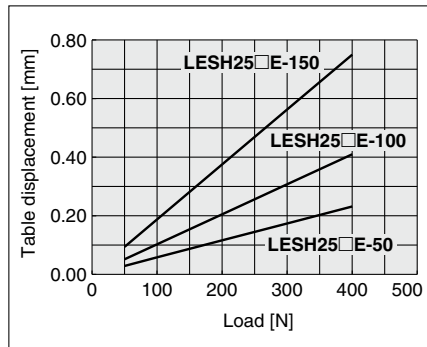
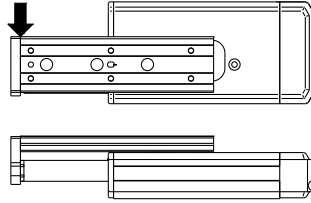

Table displacement due to yaw moment load  
Table displacement when loads are applied to the section marked with the arrow with the slide table stuck out.



### LESH25

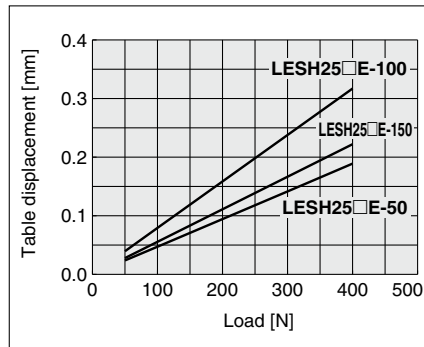
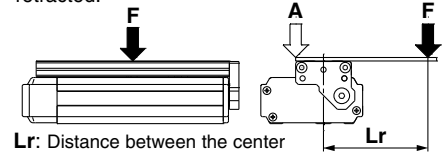

Table displacement due to roll moment load  
Table displacement of section A when loads are applied to the section F with the slide table retracted.



Lr: Distance between the center of the table and the work load center of gravity

### LESH25

Lr = 200 mm

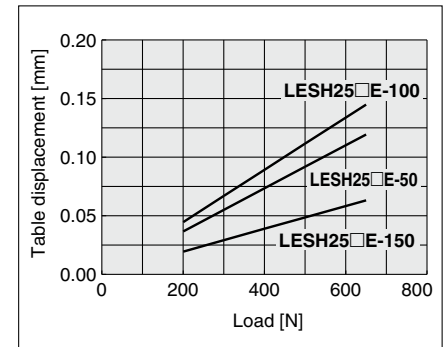



# Model Selection 1



LESH Series ▶ p. 715

## Selection Procedure For the compact type LES series, refer to page 649.



### Selection Example

**Step 1 Check the work load-speed.** <Speed-Work load graph> (Page 696)  
 Select a model based on the workpiece mass and speed while referencing the speed-work load graph.  
 Selection example) The LESH16□J-50 can be temporarily selected as a possible candidate based on the graph shown on the right side.

**Step 2 Check the cycle time.**  
 It is possible to find an approximate cycle time by using method 1, but if a more detailed cycle time is required, use method 2.

\* Although it is possible to make a suitable selection by using method 1, this calculation is based on a maximum load condition. Therefore, if a more detailed selection for each load is required, use method 2.

#### Method 1: Check the cycle time graph. (Page 697)

#### Method 2: Calculation <Speed-Work load graph> (Page 696)

Calculate the cycle time using the following calculation method. Calculation example  
 T1 to T4 can be calculated as follows.

#### Cycle time:

T can be found from the following equation.

$$T = T1 + T2 + T3 + T4 \text{ [s]}$$

- T1: Acceleration time and T3: Deceleration time can be found by the following equation.

$$T1 = V/a1 \text{ [s]} \quad T3 = V/a2 \text{ [s]}$$

- T2: Constant speed time can be found from the following equation.

$$T2 = \frac{L - 0.5 \cdot V \cdot (T1 + T3)}{V} \text{ [s]}$$

- T4: Settling time varies depending on the conditions such as motor types, load, and in position of the step data. Therefore, calculate the settling time while referencing the following value.

$$T4 = 0.15 \text{ [s]}$$

$$T1 = V/a1 = 220/5000 = 0.04 \text{ [s]}$$

$$T3 = V/a2 = 220/5000 = 0.04 \text{ [s]}$$

$$T2 = \frac{L - 0.5 \cdot V \cdot (T1 + T3)}{V} = \frac{50 - 0.5 \cdot 220 \cdot (0.04 + 0.04)}{220} = 0.19 \text{ [s]}$$

$$T4 = 0.15 \text{ [s]}$$

The cycle time can be found as follows.

$$T = T1 + T2 + T3 + T4 = 0.04 + 0.19 + 0.04 + 0.15 = 0.42 \text{ [s]}$$

### Operating conditions

- Workpiece mass: 1 [kg]
- Workpiece mounting condition:
- Speed: 220 [mm/s]
- Mounting orientation: Vertical
- Stroke: 50 [mm]
- Acceleration/Deceleration: 5000 [mm/s<sup>2</sup>]
- Cycle time: 0.5 s

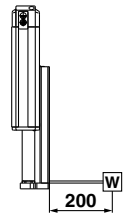

### LESH16□/Step Motor Vertical

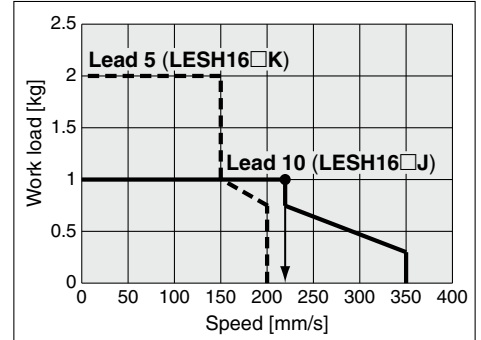

<Speed-Work load graph>

### LESH16□/Step Motor

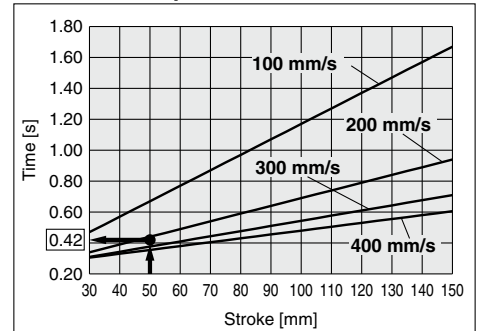

<Cycle time>

### LESH16/Pitching

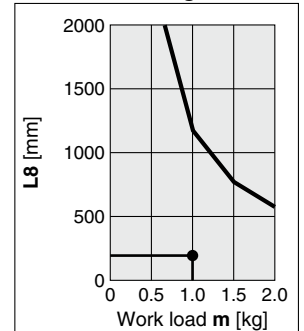

<Dynamic allowable moment>

**Step 3 Check the allowable moment.** <Static allowable moment> (Page 697)  
 <Dynamic allowable moment> (Pages 698, 699)

Confirm the moment that applies to the actuator is within the allowable range for both static and dynamic conditions.

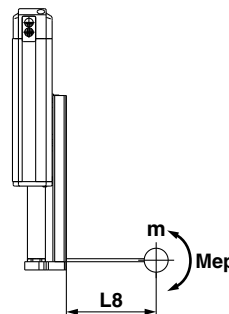

Based on the above calculation result, the LESH16□J-50 should be selected.

## Speed-Work Load Graph (Guide)

### Step Motor (Servo/24 VDC)

\* The following graphs show the values when moving force is 100%.

#### LESH8□

##### Horizontal

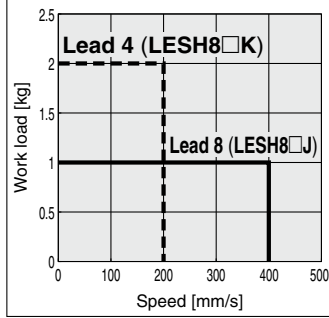

##### Vertical

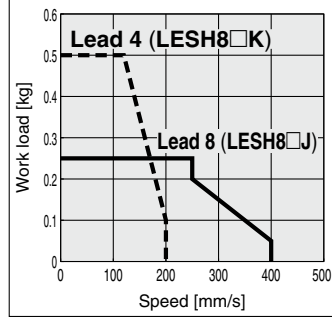

### Servo Motor (24 VDC)

\* The following graphs show the values when moving force is 250%.

#### LESH8□A

##### Horizontal

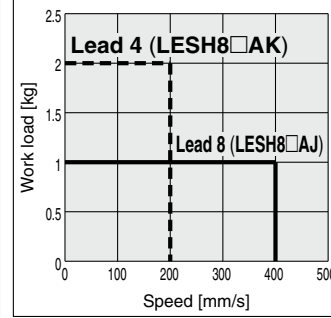

##### Vertical

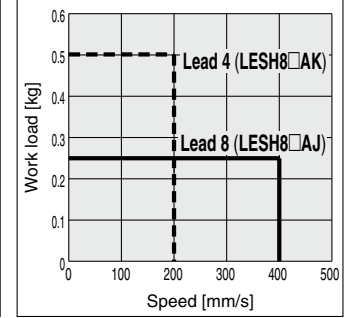

#### LESH16□

##### Horizontal

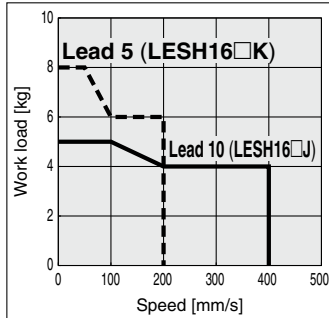

##### Vertical

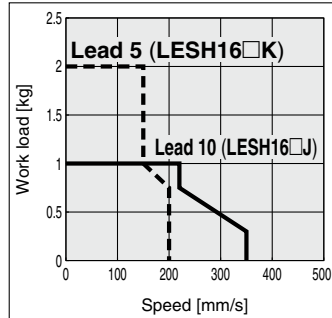

#### LESH16□A

##### Horizontal

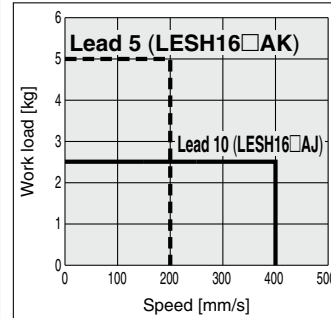

##### Vertical

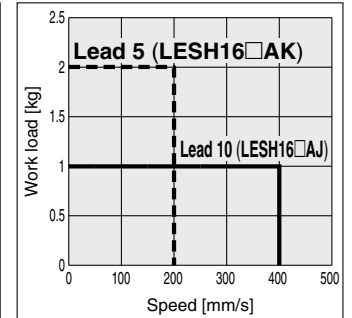

#### LESH25□

##### Horizontal

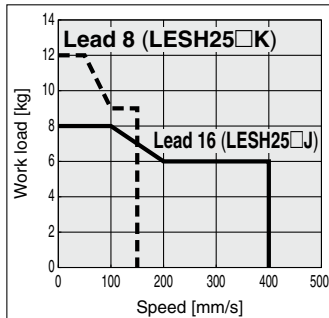

##### Vertical

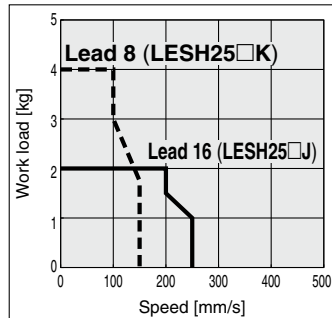

#### LESH25□A

##### Horizontal

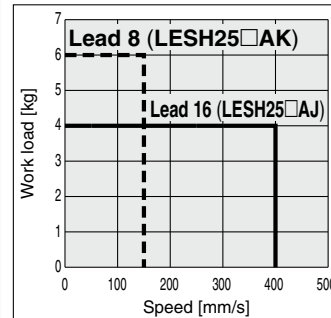

##### Vertical

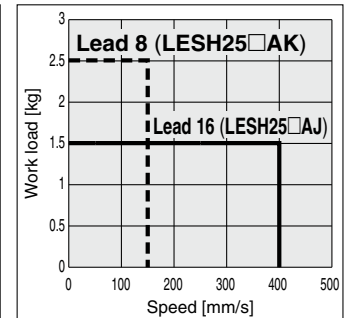

# LESH Series

Incremental (Step Motor 24 VDC)

Incremental (Servo Motor 24 VDC)

## Cycle Time Graph (Guide)

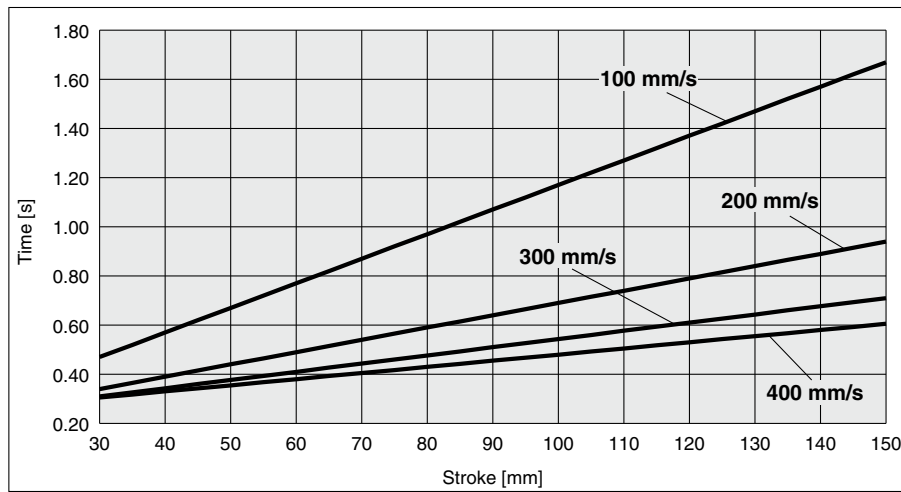

### Operating Conditions

Acceleration/Deceleration: 5000 mm/s<sup>2</sup>

In position: 0.5 mm

## Static Allowable Moment

Model		LESH8		LESH16		LESH25		
Stroke	[mm]	50	75	50	100	50	100	150
Pitching	[N·m]	11		26	43	77	112	155
Yawing	[N·m]	11						
Rolling	[N·m]	12		48		146	177	152

## Dynamic Allowable Moment

\* These graphs show the amount of allowable overhang (guide unit) when the center of gravity of the workpiece overhangs in one direction. When selecting the overhang, refer to the "Calculation of Guide Load Factor" or the Electric Actuator Model Selection Software for confirmation: <https://www.smcworld.com>

Acceleration/Deceleration — 5000 mm/s<sup>2</sup>

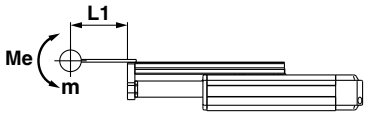
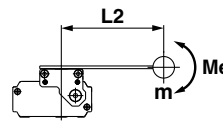
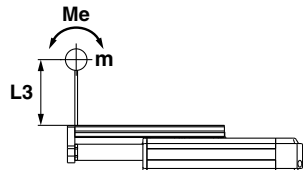
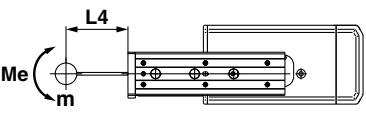
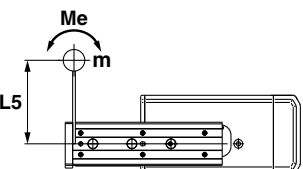
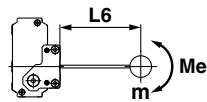
Orientation	Load overhanging direction m : Work load [kg] Me: Allowable moment [N·m] L : Overhang to the work load center of gravity [mm]	Model		
		LESH8	LESH16	LESH25
Horizontal/Bottom	 X L1 [mm]			
	 Y L2 [mm]			
	 Z L3 [mm]			
Horizontal (Wall)	 X L4 [mm]			
	 Y L5 [mm]			
	 Z L6 [mm]			



# LESH Series

Incremental (Step Motor 24 VDC)

Incremental (Servo Motor 24 VDC)

\* These graphs show the amount of allowable overhang (guide unit) when the center of gravity of the workpiece overhangs in one direction. When selecting the overhang, refer to the "Calculation of Guide Load Factor" or the Electric Actuator Model Selection Software for confirmation: <https://www.smcworld.com>

## Dynamic Allowable Moment

Acceleration/Deceleration — 5000 mm/s<sup>2</sup>

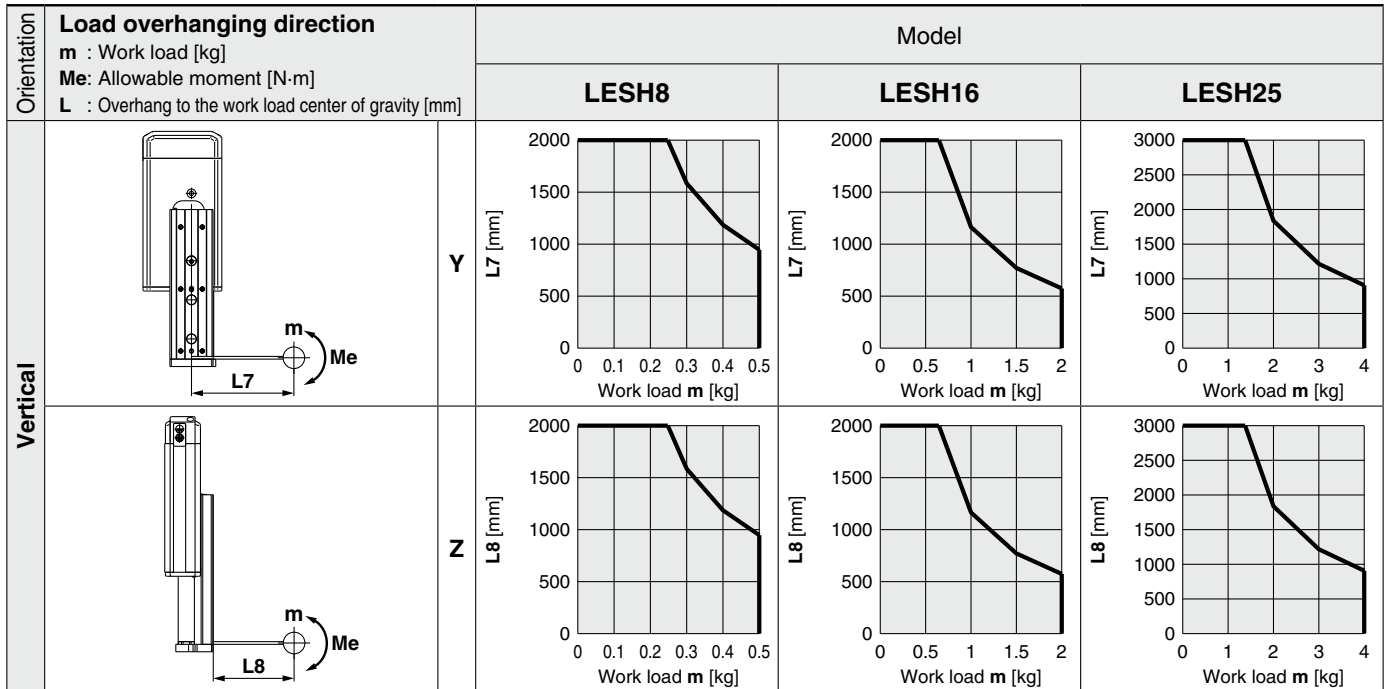

## Calculation of Guide Load Factor

1. Decide operating conditions.

Model: LESH

Size: 8/16/25

Mounting orientation: Horizontal/Bottom/Wall/Vertical

Acceleration [mm/s<sup>2</sup>]: a

Work load [kg]: m

Work load center position [mm]: Xc/Yc/Zc

2. Select the target graph while referencing the model, size, and mounting orientation.

3. Based on the acceleration and work load, find the overhang [mm]: Lx/Ly/Lz from the graph.

4. Calculate the load factor for each direction.

$$\alpha_x = X_c/L_x, \alpha_y = Y_c/L_y, \alpha_z = Z_c/L_z$$

5. Confirm the total of  $\alpha_x$ ,  $\alpha_y$ , and  $\alpha_z$  is 1 or less.

$$\alpha_x + \alpha_y + \alpha_z \leq 1$$

When 1 is exceeded, please consider a reduction of acceleration and work load, or a change of the work load center position and series.

### Mounting orientation

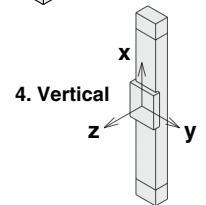
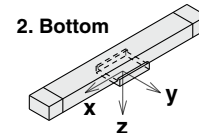
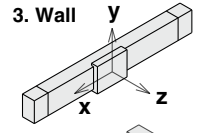
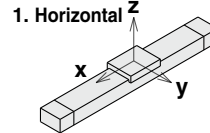

### Example

1. Operating conditions

Model: LESH

Size: 8

Mounting orientation: Horizontal

Acceleration [mm/s<sup>2</sup>]: 5000

Work load [kg]: 1.0

Work load center position [mm]: Xc = 80, Yc = 100, Zc = 60

2. Select three graphs from the top of the left side first row on page 698.

3. Lx = 480 mm, Ly = 225 mm, Lz = 1200 mm

4. The load factor for each direction can be found as follows.

$$\alpha_x = 80/480 = 0.17$$

$$\alpha_y = 100/225 = 0.44$$

$$\alpha_z = 60/1200 = 0.05$$

5.  $\alpha_x + \alpha_y + \alpha_z = 0.66 \leq 1$

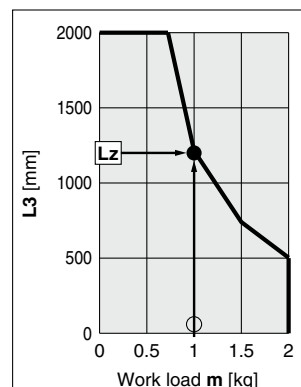
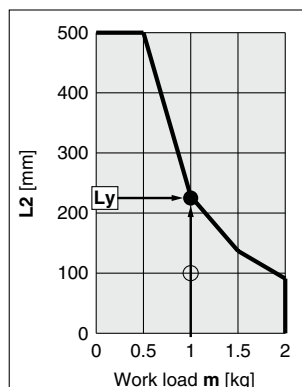
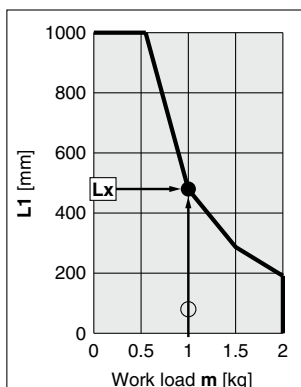



# Model Selection 2



LESH Series ▶ p. 715

## Selection Procedure For the compact type LES series, refer to page 655.

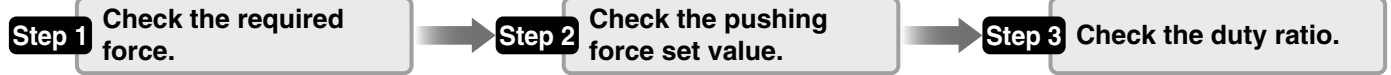

### Selection Example

#### Operating conditions

- Pushing force: 90 [N]
- Mounting orientation: Vertical upward
- Workpiece mass: 1 [kg]
- Pushing time + Operation (A): 1.5 s
- Speed: 100 [mm/s]
- Full cycle time (B): 6 s
- Stroke: 100 [mm]

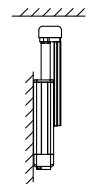

#### Step 1 Check the required force.

Calculate the approximate required force for a pushing operation.

Selection example) • Pushing force: 90 [N]  
 • Workpiece mass: 1 [kg]  
 The approximate required force can be found to be  $90 + 10 = 100$  [N].

Select a model based on the approximate required force while referencing the specifications (Pages 718, 719).

Selection example) Based on the specifications,  
 • Approximate required force: 100 [N]  
 • Speed: 100 [mm/s]  
 The LESH25□ can be temporarily selected as a possible candidate.

Then, calculate the required force for a pushing operation. If the mounting position is vertical upward, add the actuator table weight.

Selection example) Based on the table weight,  
 • LESH25□ table weight: 1.3 [kg]  
 The required force can be found to be  $100 + 13 = 113$  [N].

#### Step 2 Check the pushing force set value.

<Pushing force set value–Force graph> (Page 702)

Select a model based on the required force while referencing the pushing force set value–force graph, and confirm the pushing force set value.

Selection example) Based on the graph shown on the right side,  
 • Required force: 113 [N]  
 The LESH25□K can be temporarily selected as a possible candidate.  
 This pushing force set value is 40 [%].

#### Step 3 Check the duty ratio.

Confirm the allowable duty ratio based on the pushing force set value while referencing the allowable duty ratio.

Selection example) Based on the allowable duty ratio,  
 • Pushing force set value: 40 [%]  
 The allowable duty ratio can be found to be 30 [%].

Calculate the duty ratio for the operating conditions, and confirm it does not exceed the allowable duty ratio.

Selection example) • Pushing time + Operation (A): 1.5 s  
 • Full cycle time (B): 6 s  
 The duty ratio can be found to be  $1.5/6 \times 100 = 25$  [%], and this is within the allowable range.

Based on the above calculation result, the LESH25□K-100 should be selected. For allowable moment, the selection procedure is the same as that for the positioning control.

#### Table Weight

[kg]

Model	Stroke [mm]			
	50	75	100	150
LESH8	0.2	0.3	—	—
LESH16	0.4	—	0.7	—
LESH25	0.9	—	1.3	1.7

\* If the mounting position is vertical upward, add the table weight.

#### LESH25□/Step Motor

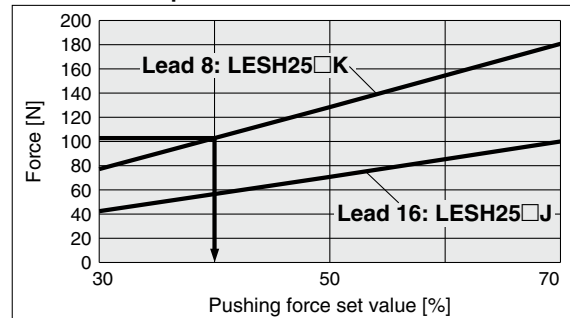

<Pushing force set value–Force graph>

#### Allowable Duty Ratio

##### Step Motor (Servo/24 VDC)

Pushing force set value [%]	Duty ratio [%]	Continuous pushing time [min]
30	—	—
50 or less	30 or less	5 or less
70 or less	20 or less	3 or less

##### Servo Motor (24 VDC)

Pushing force set value [%]	Duty ratio [%]	Continuous pushing time [min]
50	—	—
75 or less	30 or less	5 or less
100 or less	20 or less	3 or less

\* The pushing force of the LESH8□A is up to 75%.

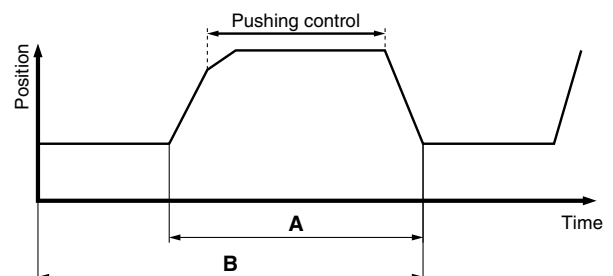

**Pushing Force Set Value–Force Graph**

**Step Motor (Servo/24 VDC)**

**LESH8□**

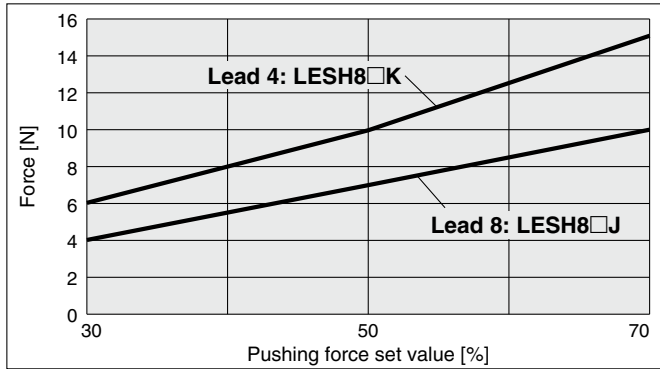

**LESH16□**

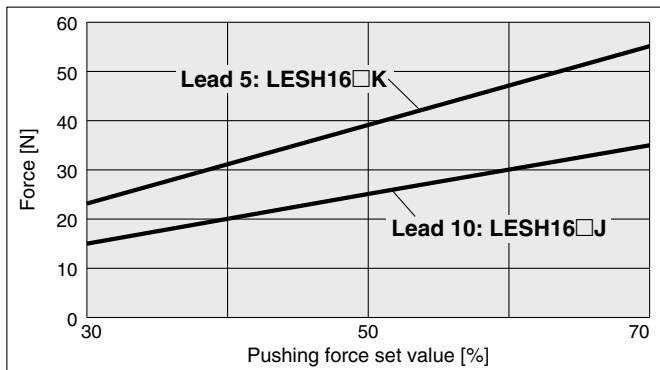

**LESH25□**

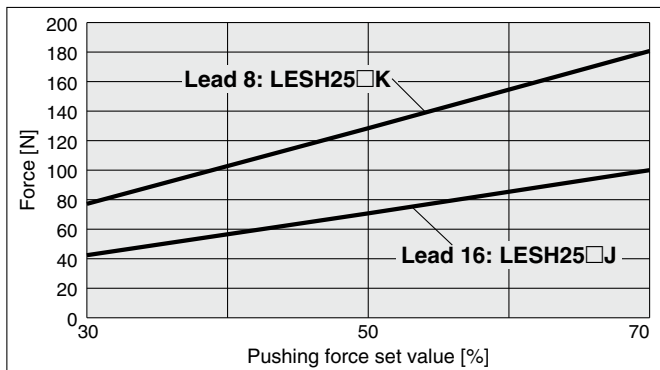

**Servo Motor (24 VDC)**

**LESH8□A**

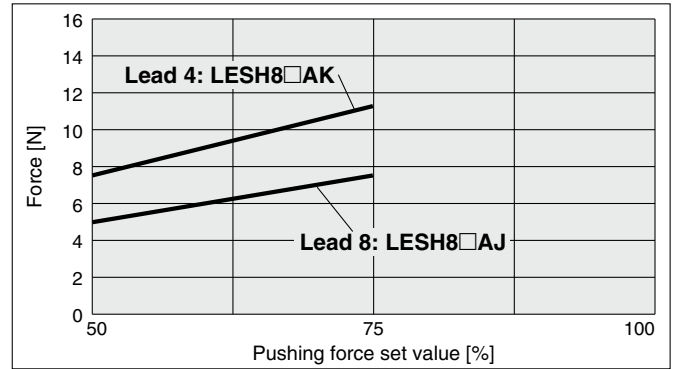

**LESH16□A**

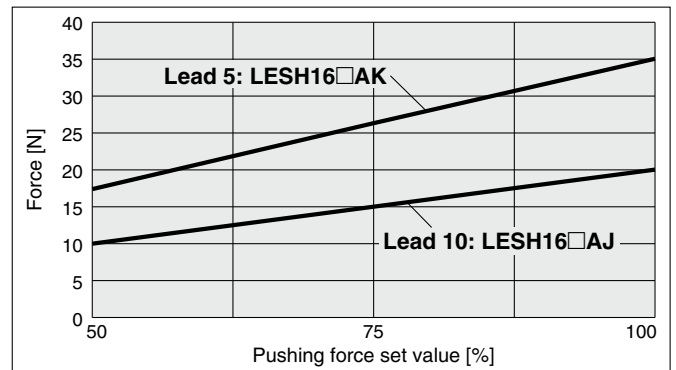

**LESH25□A**

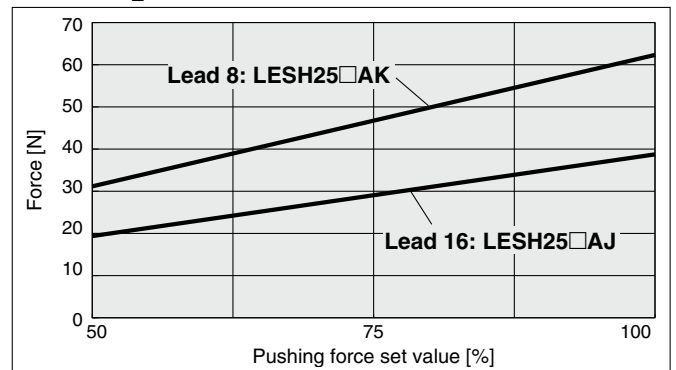

# LESH Series

Incremental (Step Motor 24 VDC)

Incremental (Servo Motor 24 VDC)

## Table Accuracy

\* These values are initial guideline values.

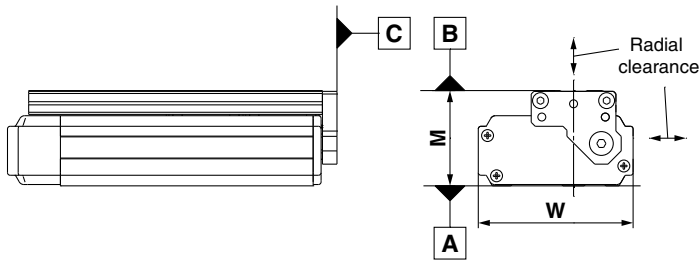

Model	LESH8	LESH16	LESH25
B side parallelism to A side [mm]	Refer to Table 1.		
B side traveling parallelism to A side [mm]	Refer to Graph 1.		
C side perpendicularity to A side [mm]	0.05	0.05	0.05
M dimension tolerance [mm]	±0.3		
W dimension tolerance [mm]	±0.2		
Radial clearance [μm]	-4 to 0	-10 to 0	-14 to 0

**Table 1 B side parallelism to A side**

Model	Stroke [mm]			
	50	75	100	150
<b>LESH8</b>	0.055	0.065	—	—
<b>LESH16</b>	0.05	—	0.08	—
<b>LESH25</b>	0.06	—	0.08	0.125

**Graph 1 B side traveling parallelism to A side**

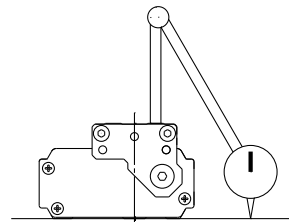
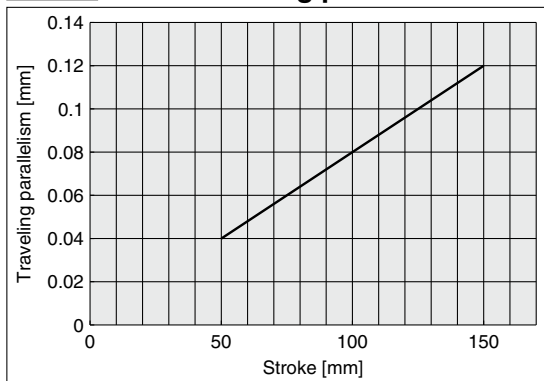

**Traveling parallelism:**  
The amount of deflection on a dial gauge when the table travels a full stroke with the body secured on a reference base surface

## Table Deflection (Reference Value)

\* These values are initial guideline values.

Table displacement due to pitch moment load  
Table displacement when loads are applied to the section marked with the arrow with the slide table stuck out.

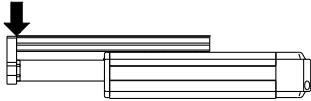

### LESH8

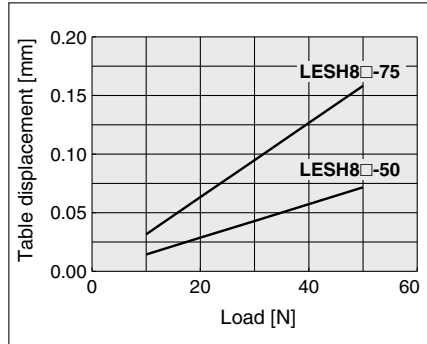
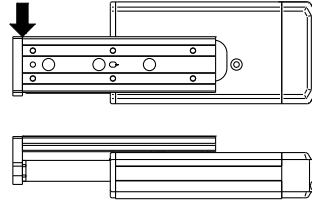

Table displacement due to yaw moment load  
Table displacement when loads are applied to the section marked with the arrow with the slide table stuck out.



### LESH8

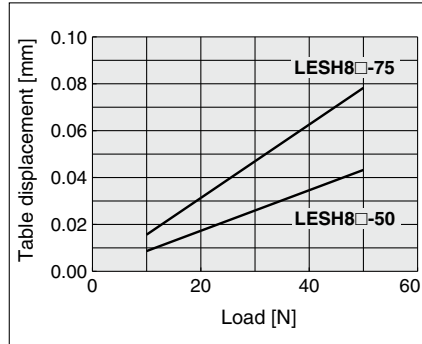
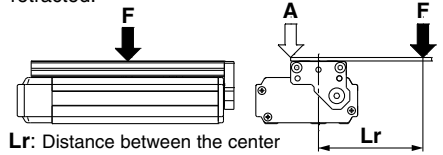

Table displacement due to roll moment load  
Table displacement of section A when loads are applied to the section F with the slide table retracted.



Lr: Distance between the center of the table and the work load center of gravity

### LESH8

Lr = 70 mm

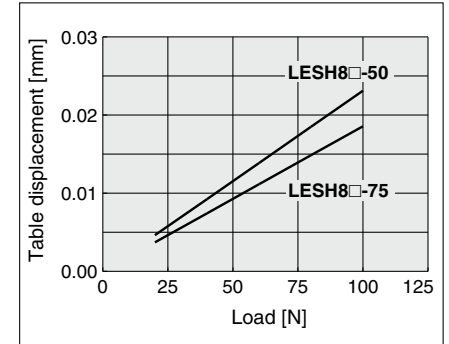

### LESH16

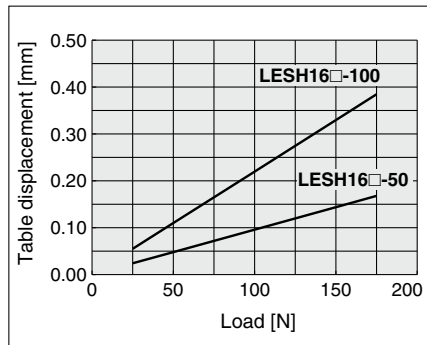

### LESH16

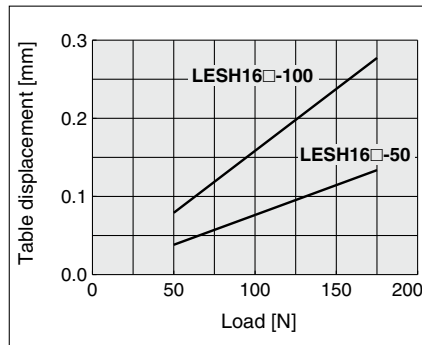

### LESH16

Lr = 120 mm

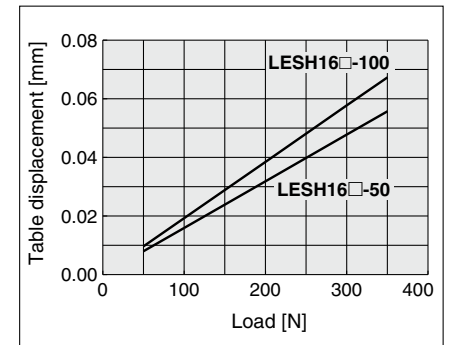

### LESH25

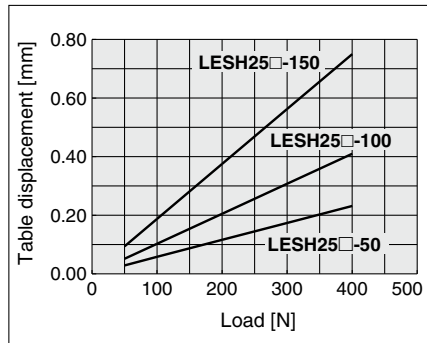

### LESH25

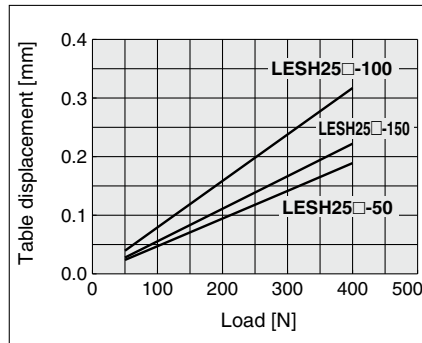

### LESH25

Lr = 200 mm

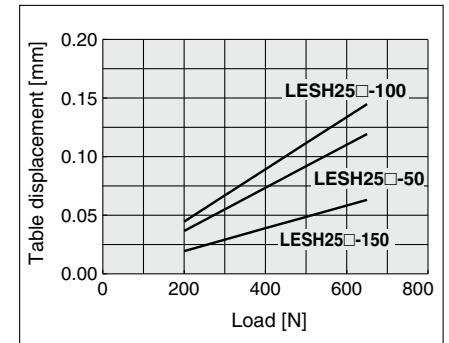

# Slide Table/High Rigidity Type

## LESH Series LESH25



\* For details, refer to page 1343 and onward.



High rigidity type

### How to Order

LESH 25 **R** **E** **J** - 50       - **R1** **CD17T**

1
2
3
4
5
6
7
8
9
10

For details on controllers, refer to the next page.

#### 1 Size

25

#### 2 Motor mounting position

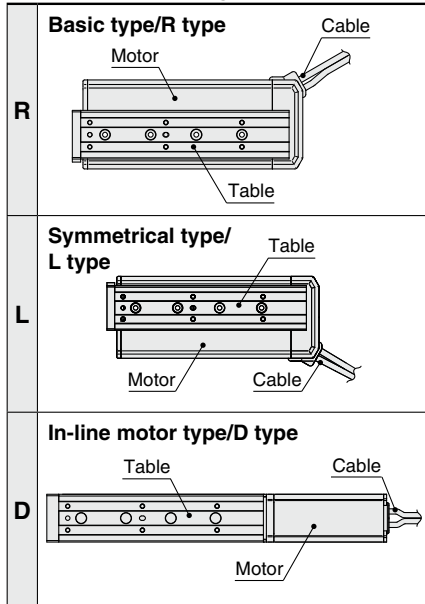

#### 3 Motor type

Symbol	Type	Compatible controllers/drivers		
<b>E</b>	Battery-less absolute (Step motor 24 VDC)	JXC51	JXCP1	JXCEF
		JXC61	JXCD1	JXC9F
		JXCE1	JXCL1	JXCPF
		JXC91	JXCM1	JXCLF

#### 4 Lead [mm]

<b>J</b>	16
<b>K</b>	8

#### 5 Stroke [mm]

Stroke	Applicable stroke
<b>50 to 150</b>	50, 100, 150

#### 6 Motor option

<b>Nil</b>	Without option
<b>B</b>	With lock

#### 7 Body option

<b>Nil</b>	Without option
<b>S</b>	Dust-protected*1

#### 8 Mounting\*2

Symbol	Mounting	R type L type	D type
<b>Nil</b>	Without side holder	●	●
<b>H</b>	With side holder (4 pcs.)	—	●

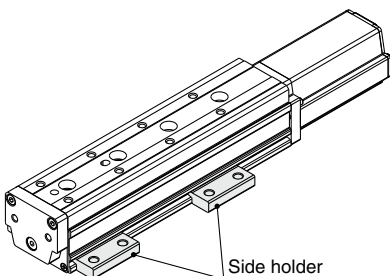

#### 9 Actuator cable type/length

Robotic cable [m]			
<b>Nil</b>	None	<b>R8</b>	8*3
<b>R1</b>	1.5	<b>RA</b>	10*3
<b>R3</b>	3	<b>RB</b>	15*3
<b>R5</b>	5	<b>RC</b>	20*3

## ⑩ Controller

<b>Nil</b>	Without controller
<b>C□1□□</b>	With controller



### Interface (Communication protocol/Input/Output)

Symbol	Type	Number of axes, Special specification	
		Standard	With STO sub-function
<b>5</b>	Parallel input (NPN)	●	
<b>6</b>	Parallel input (PNP)	●	
<b>E</b>	EtherCAT	●	●
<b>9</b>	EtherNet/IP™	●	●
<b>P</b>	PROFINET	●	●
<b>D</b>	DeviceNet®	●	
<b>L</b>	IO-Link	●	●
<b>M</b>	CC-Link	●	

### Mounting

<b>7</b>	Screw mounting
<b>8*4</b>	DIN rail

### Number of axes, Special specification

Symbol	Number of axes	Specification
<b>1</b>	Single axis	Standard
<b>F</b>	Single axis	With STO sub-function

### Communication plug connector, I/O cable\*5

Symbol	Type	Applicable interface
<b>Nil</b>	Without accessory	—
<b>S</b>	Straight type communication plug connector	DeviceNet®
<b>T</b>	T-branch type communication plug connector	CC-Link Ver. 1.10
<b>1</b>	I/O cable (1.5 m)	Parallel input (NPN) Parallel input (PNP)
<b>3</b>	I/O cable (3 m)	
<b>5</b>	I/O cable (5 m)	

- \*1 For R/L type (IP5X equivalent), a scraper is mounted on the rod cover, and gaskets are mounted on both the end covers. For D type, a scraper is mounted on the rod cover.
- \*2 For details, refer to page 713.
- \*3 Produced upon receipt of order

- \*4 The DIN rail is not included. It must be ordered separately.
- \*5 Select "Nil" for anything other than DeviceNet®, CC-Link, or parallel input.  
Select "Nil," "S," or "T" for DeviceNet® or CC-Link.  
Select "Nil," "1," "3," or "5" for parallel input.

## ⚠ Caution

### [CE/UKCA-compliant products]

EMC compliance was tested by combining the electric actuator LES series and the controller JXC series. The EMC depends on the configuration of the customer's control panel and the relationship with other electrical equipment and wiring. Therefore, compliance with the EMC directive cannot be certified for SMC components incorporated into the customer's equipment under actual operating conditions. As a result, it is necessary for the customer to verify compliance with the EMC directive for the machinery and equipment as a whole.

### [Precautions relating to differences in controller versions]

When the JXC series is to be used in combination with the battery-less absolute encoder, use a controller that is version V3.4 or S3.4 or higher. For details, refer to pages 1077 and 1078.

### [UL certification]

The JXC series controllers used in combination with electric actuators are UL certified.

## The actuator and controller are sold as a package.

Confirm that the combination of the controller and actuator is correct.

### <Check the following before use.>

- ① Check the actuator label for the model number. This number should match that of the controller.
- ② Check that the Parallel I/O configuration matches (NPN or PNP).

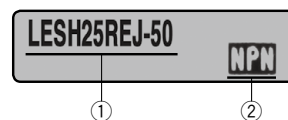

- \* Refer to the Operation Manual for using the products.  
Please download it via our website: <https://www.smcworld.com>

Type	Step data input type	EtherCAT direct input type	EtherCAT direct input type with STO sub-function	EtherNet/IP™ direct input type	EtherNet/IP™ direct input type with STO sub-function	PROFINET direct input type	PROFINET direct input type with STO sub-function	DeviceNet® direct input type	IO-Link direct input type	IO-Link direct input type with STO sub-function	CC-Link direct input type
Series	JXC51 JXC61	JXCE1	JXCEF	JXC91	JXC9F	JXCP1	JXC PF	JXCD1	JXCL1	JXCLF	JXCM1
Features	Parallel I/O	EtherCAT direct input	EtherCAT direct input with STO sub-function	EtherNet/IP™ direct input	EtherNet/IP™ direct input with STO sub-function	PROFINET direct input	PROFINET direct input with STO sub-function	DeviceNet® direct input	IO-Link direct input	IO-Link direct input with STO sub-function	CC-Link direct input
Compatible motor	Battery-less absolute (Step motor 24 VDC)										
Max. number of step data	64 points										
Power supply voltage	24 VDC										
Reference page	1017					1063					



# LESH Series

Battery-less Absolute (Step Motor 24 VDC)

## Specifications

### Battery-less Absolute (Step Motor 24 VDC)

Model		LESH25□E		
Actuator specifications	Stroke [mm]	50, 100, 150		
	Work load [kg]*1 *3	Horizontal	12	8
		Vertical	4	2
	Pushing force [N] 30% to 70%*2 *3	77 to 180		
	Speed [mm/s]*1 *3	10 to 150		
	Pushing speed [mm/s]	10 to 20		
	Max. acceleration/deceleration [mm/s <sup>2</sup> ]	5000		
	Positioning repeatability [mm]	±0.05		
	Lost motion [mm]*4	0.15 or less		
	Screw lead [mm]	8	16	
	Impact/Vibration resistance [m/s <sup>2</sup> ]*5	50/20		
	Actuation type	Slide screw + Belt (R/L type), Slide screw (D type)		
	Guide type	Linear guide (Circulating type)		
	Operating temperature range [°C]	5 to 40		
Operating humidity range [%RH]	90 or less (No condensation)			
Enclosure	IP30			
Electric specifications	Motor size	□42		
	Motor type	Battery-less absolute (Step motor 24 VDC)		
	Encoder	Battery-less absolute		
	Power supply voltage [V]	24 VDC ±10%		
	Power [W]*6 *8	Max. power 74		
Lock unit specifications	Type	Non-magnetizing lock		
	Holding force [N]	500	77	
	Power [W]*8	5		
	Rated voltage [V]	24 VDC ±10%		

\*1 Speed changes according to the work load. Check the "Speed-Work Load Graph (Guide)" on page 688.

\*2 Pushing force accuracy is ±20% (F.S.).

\*3 The speed and force may change depending on the cable length, load, and mounting conditions. Furthermore, if the cable length exceeds 5 m, then it will decrease by up to 10% for each 5 m. (At 15 m: Reduced by up to 20%)

\*4 A reference value for correcting errors in reciprocal operation

\*5 Vibration resistance: No malfunction occurred in a test ranging between 45 to 2000 Hz. The test was performed in both an axial direction and a perpendicular direction to the lead screw. (The test was performed with the actuator in the initial state.)

Impact resistance: No malfunction occurred when the actuator was tested with a drop tester in both an axial direction and a perpendicular direction to the lead screw. (The test was performed with the actuator in the initial state.)

\*6 Indicates the max. power during operation (including the controller)

This value can be used for the selection of the power supply.

\*7 With lock only

\*8 For an actuator with lock, add the power for the lock.

## Weight

### Battery-less Absolute (Step Motor 24 VDC)

Model		Basic type/R type, Symmetrical type/L type			In-line motor type/D type		
		LESH25 <sup>R</sup>			LESH25D		
Stroke [mm]		50	100	150	50	100	150
Product weight [kg]	Without lock	2.50	3.30	4.26	2.52	3.27	3.60
	With lock	2.84	3.64	4.60	2.86	3.61	3.94

## Construction: Basic Type/R Type, Symmetrical Type/L Type

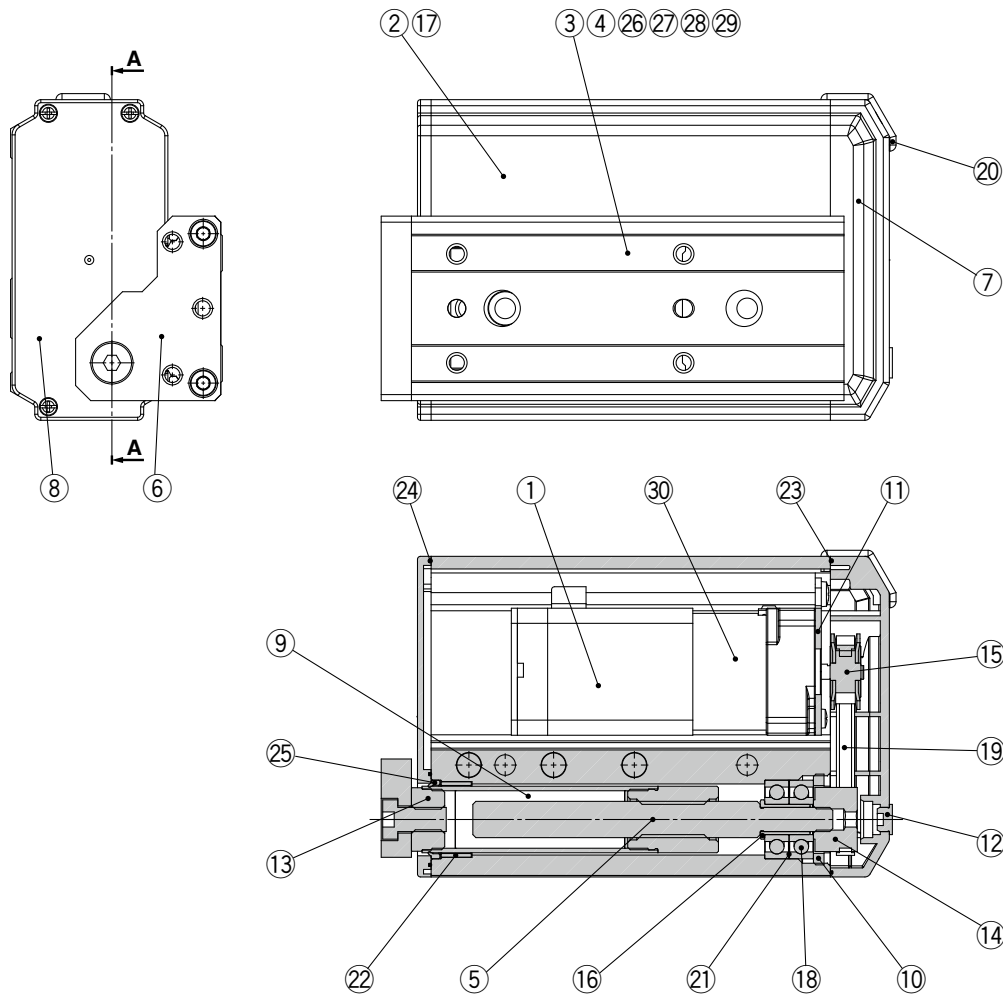

### Component Parts

No.	Description	Material	Note
1	Motor	—	—
2	Body	Aluminum alloy	Anodized
3	Table	Stainless steel	Heat treatment + Electroless nickel plating
4	Guide block	Stainless steel	Heat treatment
5	Lead screw	Stainless steel	Heat treatment + Special treatment
6	End plate	Aluminum alloy	Anodized
7	Pulley cover	Synthetic resin	—
8	End cover	Synthetic resin	—
9	Rod	Stainless steel	—
10	Bearing stopper	Structural steel	Electroless nickel plating
		Brass	Electroless nickel plating (LESH25R/L□ only)
11	Motor plate	Structural steel	—
12	Cap	Silicone rubber	—
13	Socket	Structural steel	Electroless nickel plating
14	Lead screw pulley	Aluminum alloy	—
15	Motor pulley	Aluminum alloy	—
16	Spacer	Stainless steel	LESH25R/L□ only
17	Origin stopper	Structural steel	Electroless nickel plating
18	Bearing	—	—
19	Belt	—	—
20	Grommet	Synthetic resin	—
21	Sim ring	Structural steel	—

No.	Description	Material	Note
22	Bushing	—	Dust-protected option only
23	Pulley gasket	NBR	Dust-protected option only
24	End gasket	NBR	Dust-protected option only
25	Scraper	NBR	Dust-protected option only/Rod
26	Cover	Synthetic resin	—
27	Return guide	Synthetic resin	—
28	Scraper	Stainless steel + NBR	Linear guide
29	Steel ball	Special steel	—
30	Lock	—	With lock only

### Replacement Parts/Belt

Model	Order no.
LESH25□	LE-D-1-3

### Replacement Parts/Grease Pack

Applied portion	Order no.
Guide unit	GR-S-010 (10 g) GR-S-020 (20 g)

# LESH Series

Battery-less Absolute (Step Motor 24 VDC)

## Construction: In-line Motor Type/D Type

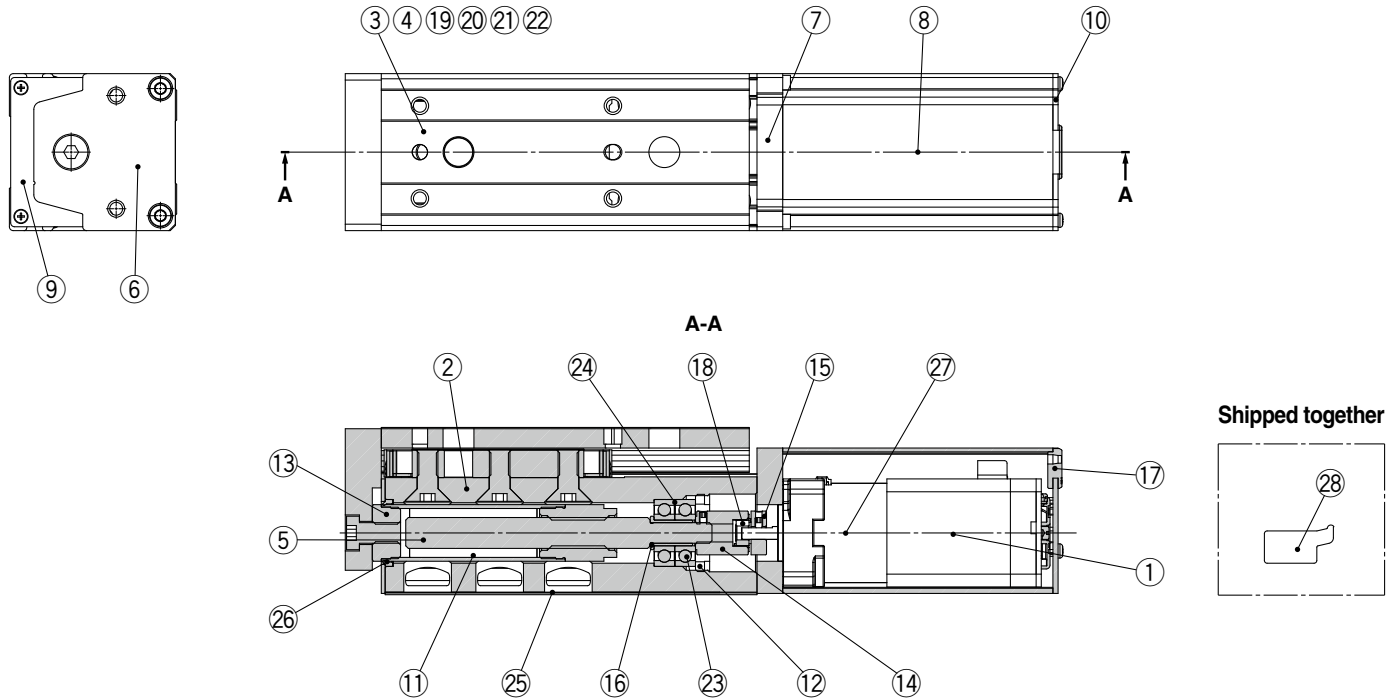

### Component Parts

No.	Description	Material	Note
1	Motor	—	—
2	Body	Aluminum alloy	Anodized
3	Table	Stainless steel	Heat treatment + Electroless nickel plating
4	Guide block	Stainless steel	Heat treatment
5	Lead screw	Stainless steel	Heat treatment + Special treatment
6	End plate	Aluminum alloy	Anodized
7	Motor flange	Aluminum alloy	Anodized
8	Motor cover	Aluminum alloy	Anodized
9	End cover	Aluminum alloy	Anodized
10	Motor end cover	Aluminum alloy	Anodized
11	Rod	Stainless steel	—
12	Bearing stopper	Structural steel	Electroless nickel plating
		Brass	Electroless nickel plating (LESH25D□ only)
13	Socket	Structural steel	Electroless nickel plating
14	Hub (Lead screw side)	Aluminum alloy	—
15	Hub (Motor side)	Aluminum alloy	—
16	Spacer	Stainless steel	LESH25D□ only
17	Grommet	NBR	—
18	Spider	NBR	—
19	Cover	Synthetic resin	—
20	Return guide	Synthetic resin	—
21	Scraper	Stainless steel + NBR	Linear guide

No.	Description	Material	Note
22	Steel ball	Special steel	—
23	Bearing	—	—
24	Sim ring	Structural steel	—
25	Masking tape	—	—
26	Scraper	NBR	Dust-protected option only/ Rod
27	Lock	—	With lock only
28	Side holder	Aluminum alloy	Anodized

### Optional Parts/Side Holder

Model	Order no.
LESH25D	LE-D-3-3

### Replacement Parts/Grease Pack

Applied portion	Order no.
Guide unit	GR-S-010 (10 g)
	GR-S-020 (20 g)

## Dimensions: Basic Type/R Type

### LESH25RE

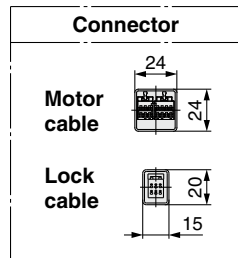
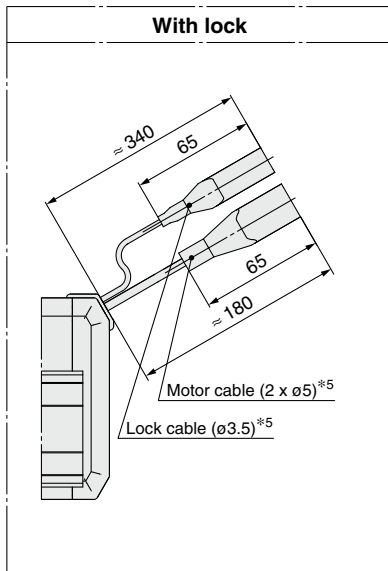
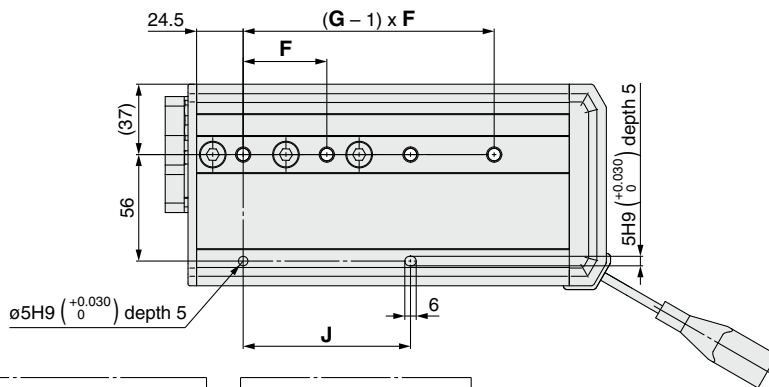
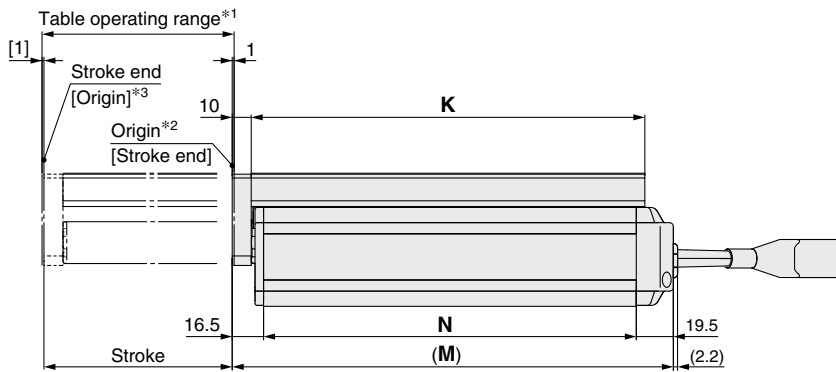
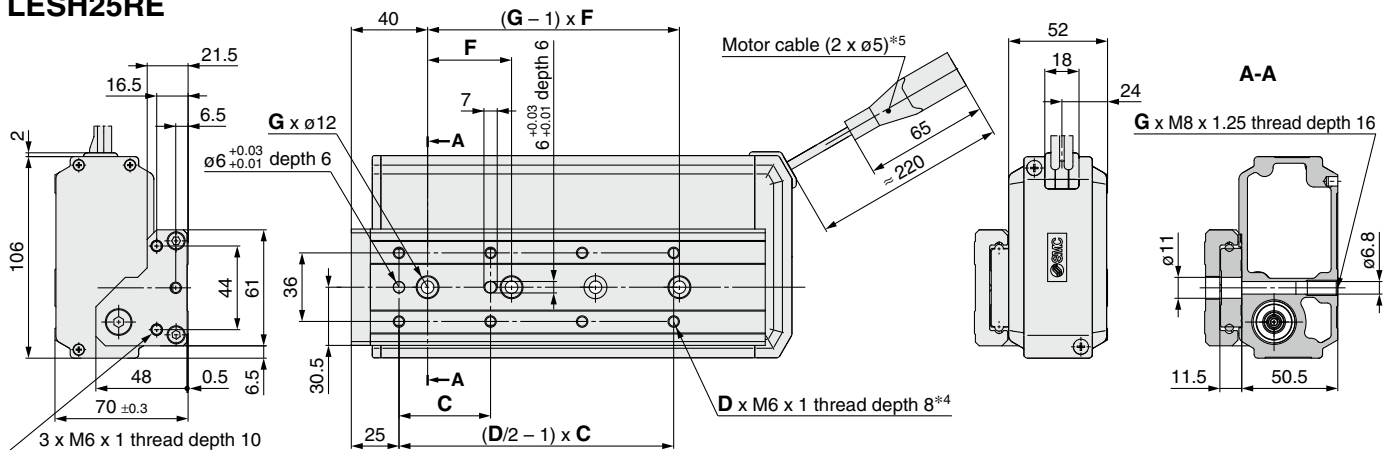

Model	C	D	F	G	J	K	M	N
LESH25RE□-50□□-□□□□□	75	4	80	2	80	143	168	132
LESH25RE□-100□□-□□□□□	48	8	44	4	88	207	232	196
LESH25RE□-150□□-□□□□□	65	8	66	4	132	285	310	274

\*1 This is the range within which the table can move when it returns to origin. Make sure that workpieces mounted on the table do not interfere with other workpieces or the facilities around the table.

\*2 Position after returning to origin

\*3 [ ] for when the direction of return to origin has changed

\*4 If workpiece retaining screws are too long, they can touch the guide block and cause a malfunction. Use screws that are between the maximum and minimum screw-in depths in length.

\*5 Secure the motor cable and lock cable so that the cables are not repeatedly bent.

# LESH Series

Battery-less Absolute (Step Motor 24 VDC)

## Dimensions: Symmetrical Type/L Type

### LESH25LE

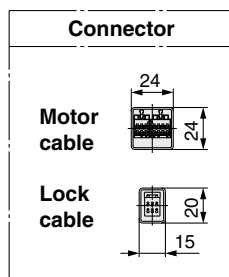
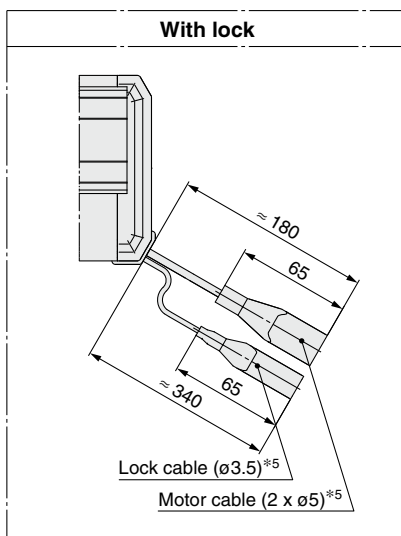
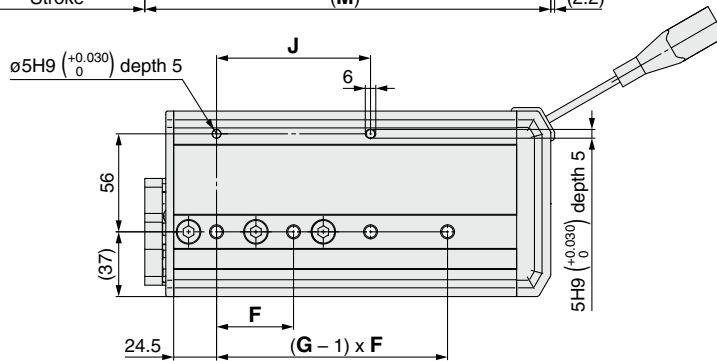
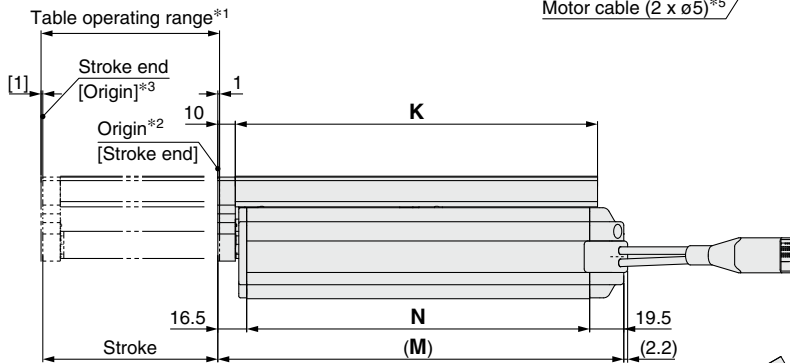
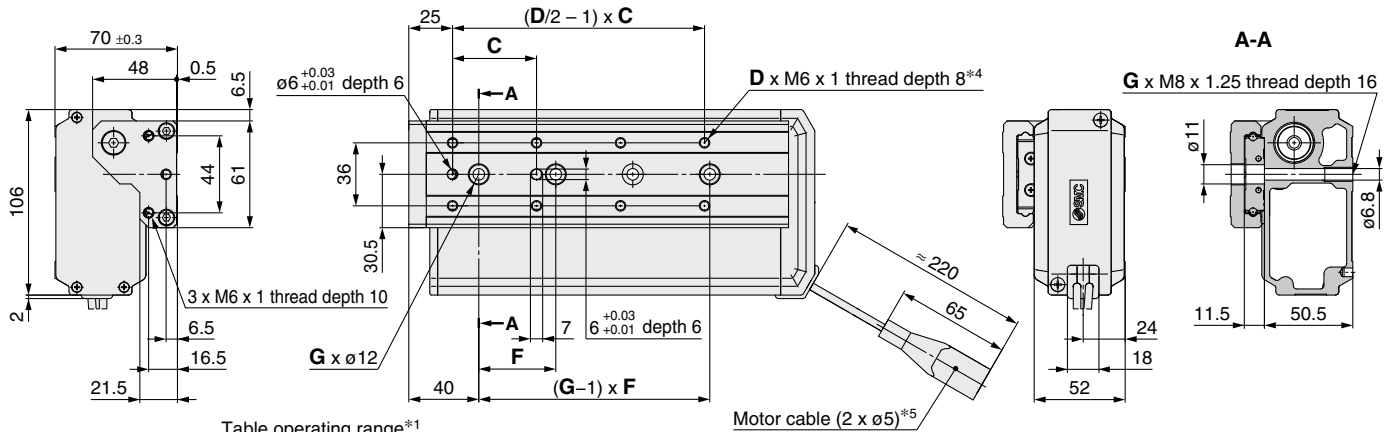

Model	C	D	F	G	J	K	M	N
LESH25LE□-50□□-□□□□□□	75	4	80	2	80	143	168	132
LESH25LE□-100□□-□□□□□□	48	8	44	4	88	207	232	196
LESH25LE□-150□□-□□□□□□	65	8	66	4	132	285	310	274

- \*1 This is the range within which the table can move when it returns to origin. Make sure that workpieces mounted on the table do not interfere with other workpieces or the facilities around the table.
- \*2 Position after returning to origin
- \*3 [ ] for when the direction of return to origin has changed
- \*4 If workpiece retaining screws are too long, they can touch the guide block and cause a malfunction. Use screws that are between the maximum and minimum screw-in depths in length.
- \*5 Secure the motor cable and lock cable so that the cables are not repeatedly bent.

## Dimensions: In-line Motor Type/D Type

### LESH25DE

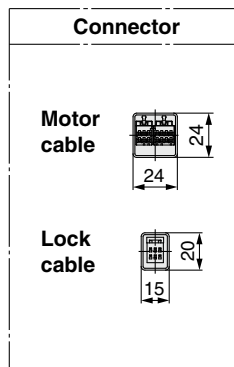
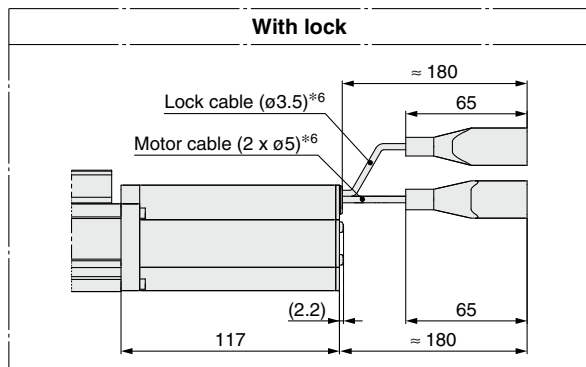
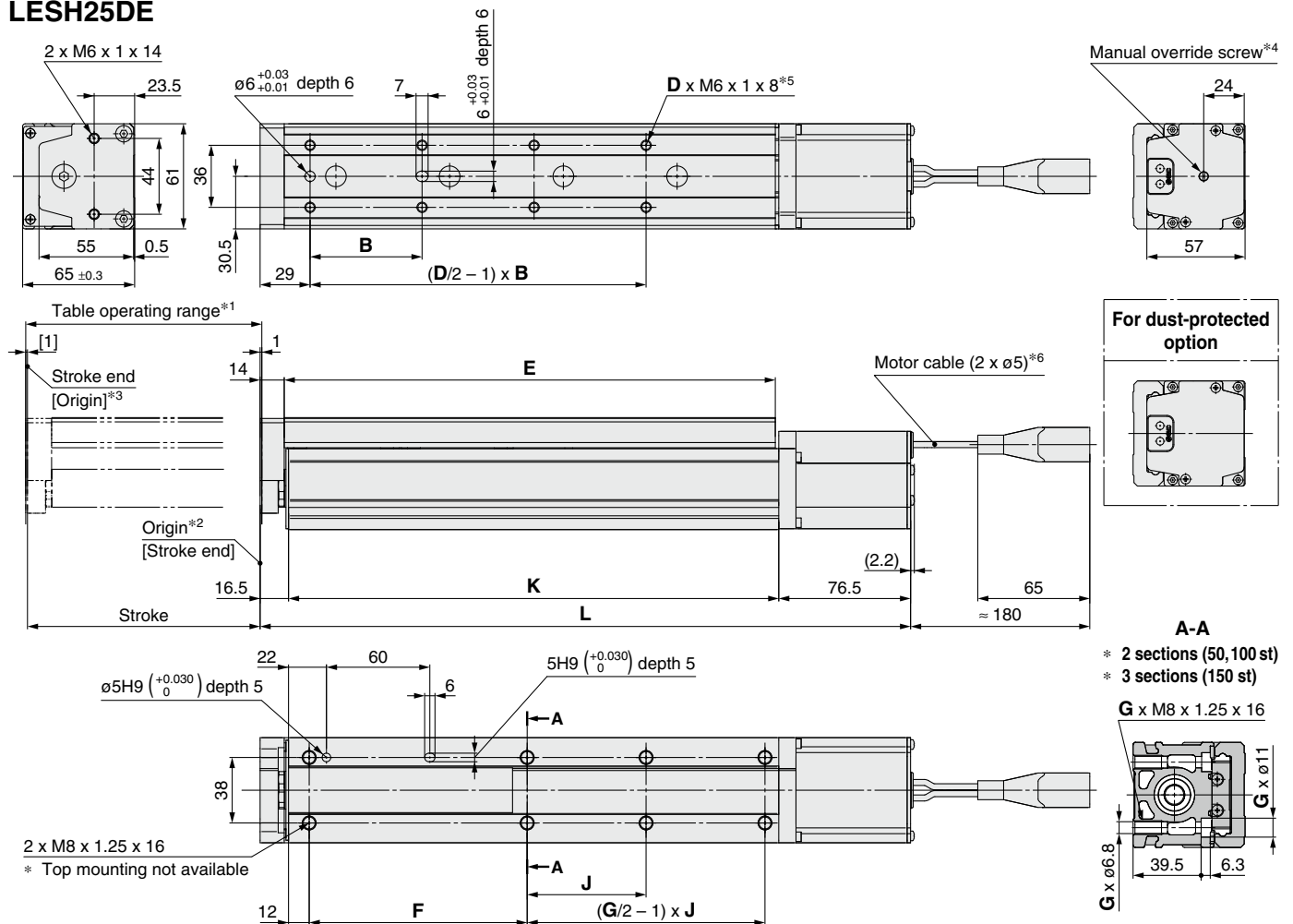

[mm]

Model	L	B	D	E	F	G	J	K
LESH25DE□-50□□-□□□□□□	237.5	75	4	143	84		40.5	144.5
LESH25DE□-50B□□-□□□□□□	278							
LESH25DE□-100□□-□□□□□□	299.5	48	8	207	98.5	4	88	206.5
LESH25DE□-100B□□-□□□□□□	340							
LESH25DE□-150□□-□□□□□□	377.5	65		285	126.5	6	69	284.5
LESH25DE□-150B□□-□□□□□□	418							

- \*1 This is the range within which the table can move when it returns to origin. Make sure that workpieces mounted on the table do not interfere with other workpieces or the facilities around the table.
- \*2 Position after returning to origin
- \*3 [ ] for when the direction of return to origin has changed
- \*4 The distance between the motor end cover and the manual override screw is up to 4 mm.  
The motor end cover hole size is  $\varnothing 5.5$ .
- \*5 If workpiece retaining screws are too long, they can touch the guide block and cause a malfunction.  
Use screws that are between the maximum and minimum screw-in depths in length.
- \*6 Secure the motor cable and lock cable so that the cables are not repeatedly bent.

# LESH Series

Battery-less Absolute (Step Motor 24 VDC)

## Side Holder (In-line Motor Type/D Type)

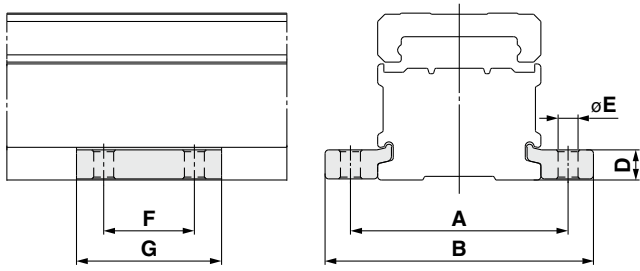

Part no.*1	A	B	D	E	F	G	Applicable model
LE-D-3-3	81	99	12	6.6	30	49	LESH25DE

[mm]

\*1 Part number for 1 side holder





# Slide Table High Rigidity Type

## LESH Series LESH8, 16, 25



### How to Order



Basic type (R type) Symmetrical type (L type) In-line motor type (D type)

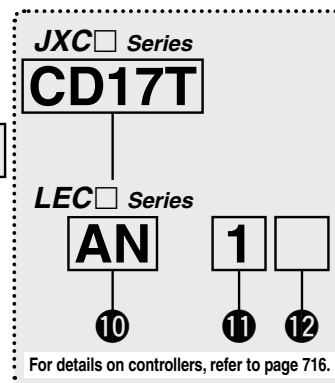
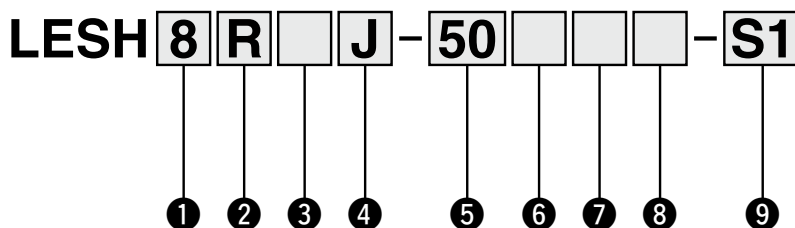

### 1 Size

8
16
25

### 4 Lead [mm]

Symbol	LESH8	LESH16	LESH25
J	8	10	16
K	4	5	8

### 5 Stroke [mm]

Stroke	Note	
	Size	Applicable stroke
50 to 75	8	50*2, 75
50 to 100	16	50*2, 100
50 to 150	25	50, 100, 150

### 6 Motor option

Nil	Without option
B	With lock*2

### Applicable motor option chart

Motor mounting position	Size	Stroke	
		50	75 or more
R/L	8	×	○
	16	×	○
	25	○	○
D	8	○	○
	16	○	○
	25	○	○

### 2 Motor mounting position

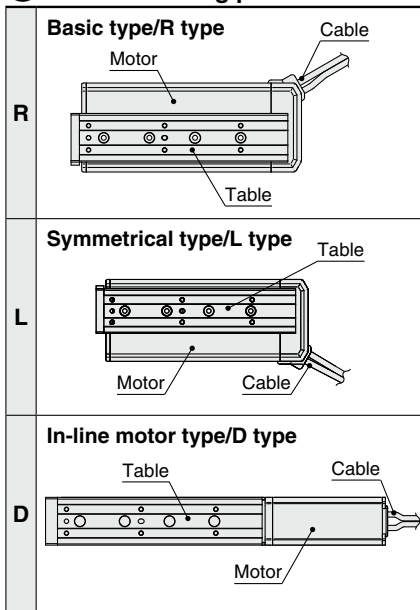

### 3 Motor type

Symbol	Type	Compatible controllers/drivers
Nil	Step motor (Servo/24 VDC)	JXC51 JXCEF
		JXC61 JXC9F
		JXCE1 JXC PF
		JXC91 JXCLF
		JXCP1
		JXCD1 LECP1
		JXCL1 LEC PA
JXCM1		
A	Servo motor*1 (24 VDC)	LECA6

### 7 Body option

Nil	Without option
S	Dust protected*3

### 9 Actuator cable type/length\*6

Standard cable [m]		Robotic cable [m]	
Nil	None	R1	1.5
S1	1.5*8	RA	10*5
S3	3*8	R3	3
S5	5*8	RB	15*5
		R5	5
		RC	20*5
		R8	8*5

### 8 Mounting\*4

Symbol	Mounting	R type L type	D type
Nil	Without side holder	●	●
H	With side holder (4 pcs.)	—	●

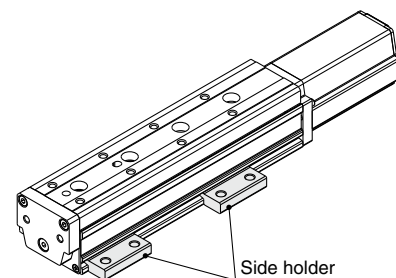

# Slide Table/High Rigidity Type **LESH Series**

Incremental (Step Motor 24 VDC)

Incremental (Servo Motor 24 VDC)

## JXC Series (For details, refer to page 717.)

### 10 Controller

Nil	Without controller
C□1□□	With controller

**C D 1 7 T**

### Interface (Communication protocol/Input/Output)

Symbol	Type	Number of axes, Special specification	
		Standard	With STO sub-function
5	Parallel input (NPN)	●	
6	Parallel input (PNP)	●	
E	EtherCAT	●	●
9	EtherNet/IP™	●	●
P	PROFINET	●	●
D	DeviceNet®	●	
L	IO-Link	●	●
M	CC-Link	●	

### Mounting

7	Screw mounting
8*12	DIN rail

### Number of axes, Special specification

Symbol	Number of axes	Specification
1	Single axis	Standard
F	Single axis	With STO sub-function

### Communication plug connector, I/O cable\*13

Symbol	Type	Applicable interface
Nil	Without accessory	—
S	Straight type communication plug connector	DeviceNet®
T	T-branch type communication plug connector	CC-Link Ver. 1.10
1	I/O cable (1.5 m)	Parallel input (NPN) Parallel input (PNP)
3	I/O cable (3 m)	
5	I/O cable (5 m)	



## LEC Series (For details, refer to page 717.)

**AN 1 □**

⑩ ⑪ ⑫

### 10 Controller/Driver type\*7

Nil	Without controller/driver	
6N	<b>LECA6</b>	NPN
6P	(Step data input type)	PNP
1N	<b>LECP1</b> *8	NPN
1P	(Programless type)	PNP
AN	<b>LECPA</b> *8 *9	NPN
AP	(Pulse input type)	PNP

### 11 I/O cable length\*10

Nil	Without cable (Without communication plug connector)
1	1.5 m
3	3 m*11
5	5 m*11

### 12 Controller/Driver mounting

Nil	Screw mounting
D	DIN rail*12



- \*1 LESH25DA is not available.
- \*2 As the applicable motor mounting positions and motor options vary depending on the stroke, refer to the applicable motor option chart on page 715.
- \*3 For R/L type (IP5X equivalent), a scraper is mounted on the rod cover, and gaskets are mounted on both the end covers. For D type, a scraper is mounted on the rod cover.
- \*4 Refer to page 731 for details.
- \*5 Produced upon receipt of order (Robotic cable only)
- \*6 The standard cable should only be used on fixed parts. For use on moving parts, select the robotic cable. Refer to pages 1092 and 1093 if only the actuator cable is required.
- \*7 For details on controllers/drivers and compatible motors, refer to the compatible controllers/drivers on the next page.

- \*8 Only available for the motor type "Step motor"
- \*9 When pulse signals are open collector, order the current limiting resistor (LEC-PA-R-□) on page 1062 separately.
- \*10 When "Without controller/driver" is selected for controller/driver types, I/O cable cannot be selected. Refer to page 1037 (For LECA6), page 1047 (For LECP1), or page 1062 (For LECPA) if an I/O cable is required.
- \*11 When "Pulse input type" is selected for controller/driver types, pulse input usable only with differential. Only 1.5 m cables usable with open collector
- \*12 The DIN rail is not included. It must be ordered separately.
- \*13 Select "Nil" for anything other than DeviceNet®, CC-Link, or parallel input. Select "Nil," "S," or "T" for DeviceNet® or CC-Link. Select "Nil," "1," "3," or "5" for parallel input.

## ⚠ Caution

### [CE/UKCA-compliant products]

- ① EMC compliance was tested by combining the electric actuator LES series and the controller LEC/JXC series. The EMC depends on the configuration of the customer's control panel and the relationship with other electrical equipment and wiring. Therefore, compliance with the EMC directive cannot be certified for SMC components incorporated into the customer's equipment under actual operating conditions. As a result, it is necessary for the customer to verify compliance with the EMC directive for the machinery and equipment as a whole.
- ② For the incremental (servo motor 24 VDC) specification, EMC compliance was tested by installing a noise filter set (LEC-NFA). Refer to page 1037 for the noise filter set. Refer to the LECA series Operation Manual for installation.

### [UL-compliant products (For the LEC series)]

When compliance with UL is required, the electric actuator and controller/driver should be used with a UL1310 Class 2 power supply.

## The actuator and controller/driver are sold as a package.

Confirm that the combination of the controller/driver and the actuator is correct.

### <Check the following before use.>

- ① Check the actuator label for model number. This number should match that of the controller/driver.
- ② Check that the Parallel I/O configuration matches (NPN or PNP).

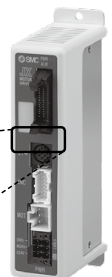
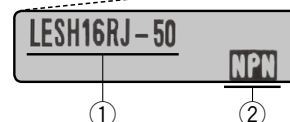





\* Refer to the Operation Manual for using the products. Please download it via our website: <https://www.smcworld.com>











# LESH Series

Incremental (Step Motor 24 VDC)

Incremental (Servo Motor 24 VDC)

## Compatible Controllers/Drivers

Type	Step data input type	Step data input type	Programless type	Pulse input type
				
Series	<b>JXC51 JXC61</b>	<b>LECA6</b>	<b>LECP1</b>	<b>LECPA</b>
Features	Parallel I/O	Parallel I/O	Capable of setting up operation (step data) without using a PC or teaching box	Operation by pulse signals
Compatible motor	Step motor (Servo/24 VDC)	Servo motor (24 VDC)	Step motor (Servo/24 VDC)	
Max. number of step data	64 points		14 points	—
Power supply voltage	24 VDC			
Reference page	1017	1031	1042	1057

Type	EtherCAT direct input type	EtherCAT direct input type with STO sub-function	EtherNet/IP™ direct input type	EtherNet/IP™ direct input type with STO sub-function	PROFINET direct input type	PROFINET direct input type with STO sub-function	DeviceNet® direct input type	IO-Link direct input type	IO-Link direct input type with STO sub-function	CC-Link direct input type
										
Series	<b>JXCE1</b>	<b>JXCEF</b>	<b>JXC91</b>	<b>JXC9F</b>	<b>JXC9P</b>	<b>JXC9PF</b>	<b>JXCD1</b>	<b>JXCL1</b>	<b>JXCLF</b>	<b>JXCM1</b>
Features	EtherCAT direct input	EtherCAT direct input with STO sub-function	EtherNet/IP™ direct input	EtherNet/IP™ direct input with STO sub-function	PROFINET direct input	PROFINET direct input with STO sub-function	DeviceNet® direct input	IO-Link direct input	IO-Link direct input with STO sub-function	CC-Link direct input
Compatible motor	Step motor (Servo/24 VDC)									
Max. number of step data	64 points									
Power supply voltage	24 VDC									
Reference page	1063									

## Specifications

### Step Motor (Servo/24 VDC)

Model		LESH8□		LESH16□		LESH25□		
Actuator specifications	Stroke [mm]	50, 75		50, 100		50, 100, 150		
	Work load [kg]*1 *3	Horizontal	2	1	8	5	12	8
		Vertical	0.5	0.25	2	1	4	2
	Pushing force [N] 30% to 70%*2 *3	6 to 15	4 to 10	23.5 to 55	15 to 35	77 to 180	43 to 100	
	Speed [mm/s]*1 *3	10 to 200	20 to 400	10 to 200	20 to 400	10 to 150	20 to 400	
	Pushing speed [mm/s]	10 to 20	20	10 to 20	20	10 to 20	20	
	Max. acceleration/deceleration [mm/s <sup>2</sup> ]	5000						
	Positioning repeatability [mm]	±0.05						
	Lost motion [mm]*4	0.15 or less						
	Screw lead [mm]	4	8	5	10	8	16	
	Impact/Vibration resistance [m/s <sup>2</sup> ]*5	50/20						
	Actuation type	Slide screw + Belt (R/L type), Slide screw (D type)						
	Guide type	Linear guide (Circulating type)						
	Operating temperature range [°C]	5 to 40						
Operating humidity range [%RH]	90 or less (No condensation)							
Enclosure	IP30							
Electric specifications	Motor size	□20		□28		□42		
	Motor type	Step motor (Servo/24 VDC)						
	Encoder	Incremental						
	Power supply voltage [V]	24 VDC ±10%						
	Power [W]*6 *8	Max. power 35		Max. power 60		Max. power 74		
Lock unit specifications	Type	Non-magnetizing lock						
	Holding force [N]	24	2.5	300	48	500	77	
	Power [W]*8	3.5		2.9		5		
	Rated voltage [V]	24 VDC ±10%						

\*1 Speed changes according to the work load. Check the "Speed-Work Load Graph (Guide)" on page 696.

\*2 Pushing force accuracy is ±20% (F.S.).

\*3 The speed and force may change depending on the cable length, load, and mounting conditions. Furthermore, if the cable length exceeds 5 m, then it will decrease by up to 10% for each 5 m. (At 15 m: Reduced by up to 20%)

\*4 A reference value for correcting errors in reciprocal operation

\*5 Vibration resistance: No malfunction occurred in a test ranging between 45 to 2000 Hz. The test was performed in both an axial direction and a perpendicular direction to the lead screw. (The test was performed with the actuator in the initial state.)

Impact resistance: No malfunction occurred when the actuator was tested with a drop tester in both an axial direction and a perpendicular direction to the lead screw. (The test was performed with the actuator in the initial state.)

\*6 Indicates the max. power during operation (including the controller)

This value can be used for the selection of the power supply.

\*7 With lock only

\*8 For an actuator with lock, add the power for the lock.

# LESH Series

Incremental (Step Motor 24 VDC)

Incremental (Servo Motor 24 VDC)

## Specifications

### Servo Motor (24 VDC)

Model		LESH8□A		LESH16□A		LESH25□A*1		
Actuator specifications	Stroke [mm]	50, 75		50, 100		50, 100, 150		
	Work load [kg]	Horizontal	2	1	5	2.5	6	4
		Vertical	0.5	0.25	2	1	2.5	1.5
	Pushing force 50 to 100% [N]*2	7.5 to 11	5 to 7.5	17.5 to 35	10 to 20	31 to 62	19 to 38	
	Speed [mm/s]	1 to 200	1 to 400	1 to 200	1 to 400	1 to 150	1 to 400	
	Pushing speed [mm/s]*2	1 to 20						
	Max. acceleration/deceleration [mm/s <sup>2</sup> ]	5000						
	Positioning repeatability [mm]	±0.05						
	Lost motion [mm]*3	0.15 or less						
	Screw lead [mm]	4	8	5	10	8	16	
	Impact/Vibration resistance [m/s <sup>2</sup> ]*4	50/20						
	Actuation type	Slide screw + Belt (R/L type), Slide screw (D type)						
	Guide type	Linear guide (Circulating type)						
	Operating temperature range [°C]	5 to 40						
	Operating humidity range [%RH]	90 or less (No condensation)						
Enclosure	IP30							
Electric specifications	Motor size	□20		□28		□42		
	Motor output [W]	10		30		36		
	Motor type	Servo motor (24 VDC)						
	Encoder	Incremental						
	Power supply voltage [V]	24 VDC ±10%						
Lock unit specifications	Power [W]*5 *7	Max. power 84		Max. power 124		Max. power 158		
	Type	Non-magnetizing lock						
	Holding force [N]	24	2.5	300	48	500	77	
	Power [W]*7	3.5		2.9		5		
Rated voltage [V]	24 VDC ±10%							

\*1 LESH25DA is not available.

\*2 The pushing force values for LESH8□A is 50% to 75%. Pushing force accuracy is ±20% (F.S.).

\*3 A reference value for correcting errors in reciprocal operation

\*4 Vibration resistance: No malfunction occurred in a test ranging between 45 to 2000 Hz. The test was performed in both an axial direction and a perpendicular direction to the lead screw. (The test was performed with the actuator in the initial state.)

Impact resistance: No malfunction occurred when the actuator was tested with a drop tester in both an axial direction and a perpendicular direction to the lead screw. (The test was performed with the actuator in the initial state.)

\*5 Indicates the max. power during operation (including the controller)  
This value can be used for the selection of the power supply.

\*6 With lock only

\*7 For an actuator with lock, add the power for the lock.

## Weight

### Step Motor (Servo/24 VDC), Servo Motor (24 VDC) Common

Model		Basic type/R type, Symmetrical type/L type							In-line motor type/D type						
		LESH8□(A)		LESH16□(A)		LESH25□(A)			LESH8D(A)		LESH16D(A)		LESH25D		
Stroke [mm]		50	75	50	100	50	100	150	50	75	50	100	50	100	150
Product weight [kg]	Without lock	0.55	0.70	1.15	1.60	2.50	3.30	4.26	0.57	0.70	1.25	1.70	2.52	3.27	3.60
	With lock	—	0.76	—	1.71	2.84	3.64	4.60	0.63	0.76	1.36	1.81	2.86	3.61	3.94

## Construction: Basic Type/R Type, Symmetrical Type/L Type

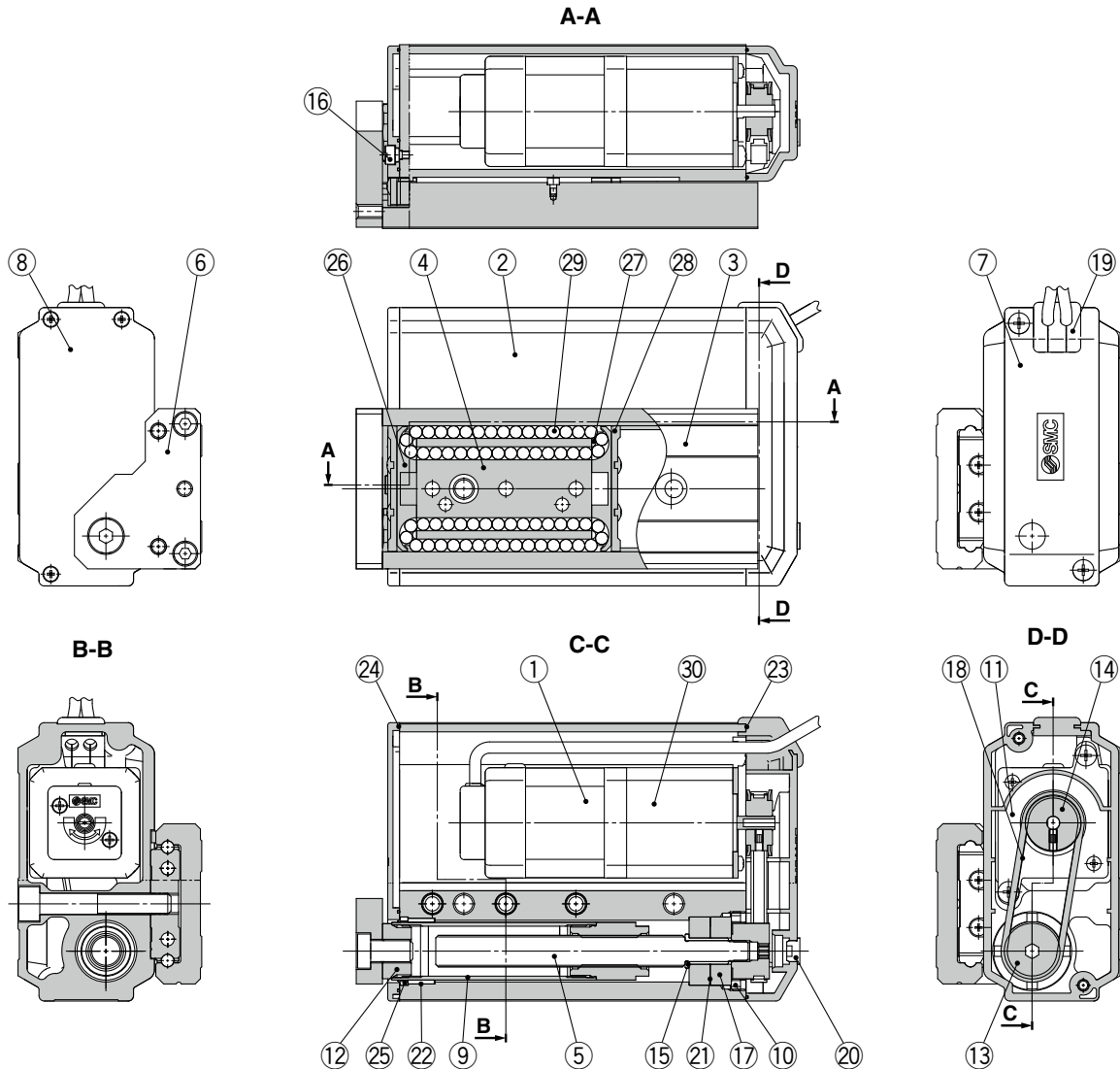

### Component Parts

No.	Description	Material	Note
1	Motor	—	—
2	Body	Aluminum alloy	Anodized
3	Table	Stainless steel	Heat treatment + Electroless nickel plating
4	Guide block	Stainless steel	Heat treatment
5	Lead screw	Stainless steel	Heat treatment + Special treatment
6	End plate	Aluminum alloy	Anodized
7	Pulley cover	Synthetic resin	—
8	End cover	Synthetic resin	—
9	Rod	Stainless steel	—
10	Bearing stopper	Structural steel	Electroless nickel plating
		Brass	Electroless nickel plating (LESH25R/L□ only)
11	Motor plate	Structural steel	—
12	Socket	Structural steel	Electroless nickel plating
13	Lead screw pulley	Aluminum alloy	—
14	Motor pulley	Aluminum alloy	—
15	Spacer	Stainless steel	—
16	Origin stopper	Structural steel	Electroless nickel plating
17	Bearing	—	—
18	Belt	—	—
19	Grommet	Synthetic resin	—
20	Cap	Silicone rubber	—

No.	Description	Material	Note
21	Sim ring	Structural steel	—
22	Bushing	—	Dust-protected option only
23	Pulley gasket	NBR	Dust-protected option only
24	End gasket	NBR	Dust-protected option only
25	Scraper	NBR	Dust-protected option only/Rod
26	Cover	Synthetic resin	—
27	Return guide	Synthetic resin	—
28	Scraper	Stainless steel + NBR	Linear guide
29	Steel ball	Special steel	—
30	Lock	—	With lock only

### Replacement Parts/Belt

Model	Order no.
LESH8□	LE-D-1-1
LESH16□	LE-D-1-2
LESH25□	LE-D-1-3
LESH25□A	LE-D-1-4

### Replacement Parts/Grease Pack

Applied portion	Order no.
Guide unit	GR-S-010 (10 g)
	GR-S-020 (20 g)



# LESH Series

Incremental (Step Motor 24 VDC)

Incremental (Servo Motor 24 VDC)

## Construction: In-line Motor Type/D Type

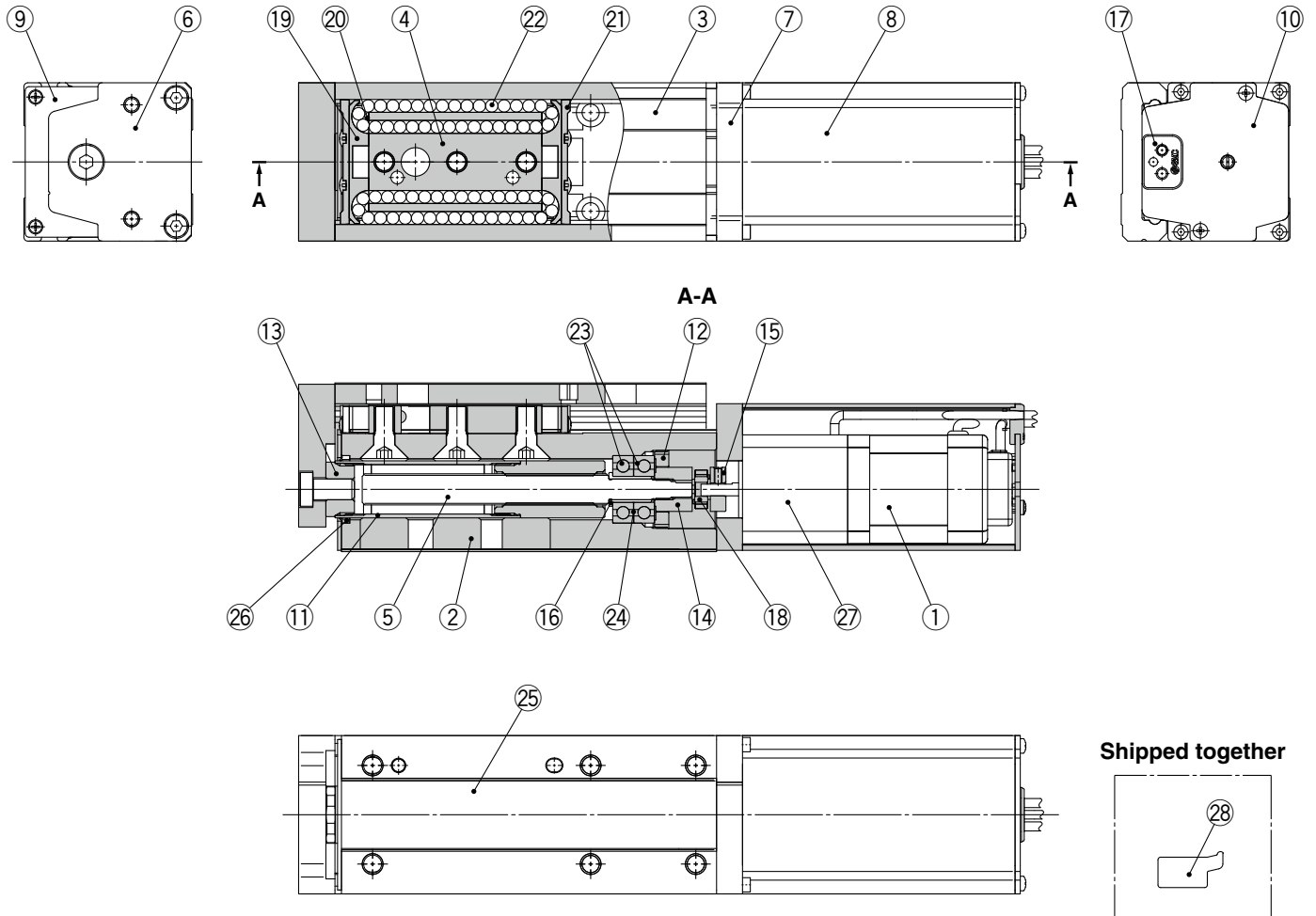

Shipped together

### Component Parts

No.	Description	Material	Note
1	Motor	—	—
2	Body	Aluminum alloy	Anodized
3	Table	Stainless steel	Heat treatment + Electroless nickel plating
4	Guide block	Stainless steel	Heat treatment
5	Lead screw	Stainless steel	Heat treatment + Special treatment
6	End plate	Aluminum alloy	Anodized
7	Motor flange	Aluminum alloy	Anodized
8	Motor cover	Aluminum alloy	Anodized
9	End cover	Aluminum alloy	Anodized
10	Motor end cover	Aluminum alloy	Anodized
11	Rod	Stainless steel	—
12	Bearing stopper	Structural steel	Electroless nickel plating
		Brass	Electroless nickel plating (LESH25D□ only)
13	Socket	Structural steel	Electroless nickel plating
14	Hub (Lead screw side)	Aluminum alloy	—
15	Hub (Motor side)	Aluminum alloy	—
16	Spacer	Stainless steel	LESH25D□ only
17	Grommet	NBR	—
18	Spider	NBR	—
19	Cover	Synthetic resin	—
20	Return guide	Synthetic resin	—
21	Scraper	Stainless steel + NBR	Linear guide

No.	Description	Material	Note
22	Steel ball	Special steel	—
23	Bearing	—	—
24	Sim ring	Structural steel	—
25	Masking tape	—	—
26	Scraper	NBR	Dust-protected option only/ Rod
27	Lock	—	With lock only
28	Side holder	Aluminum alloy	Anodized

### Optional Parts/Side Holder

Model	Order no.
LESH8D	LE-D-3-1
LESH16D	LE-D-3-2
LESH25D	LE-D-3-3

### Replacement Parts/Grease Pack

Applied portion	Order no.
Guide unit	GR-S-010 (10 g)
	GR-S-020 (20 g)

## Dimensions: Basic Type/R Type

### LESH8R

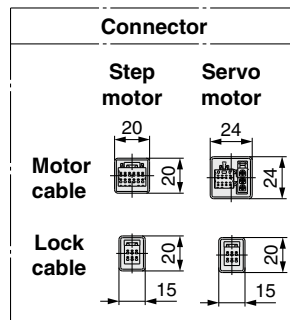
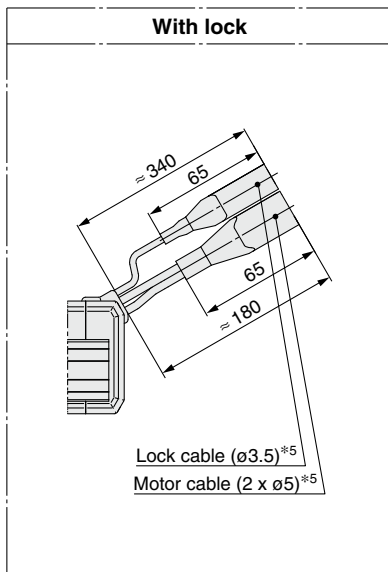
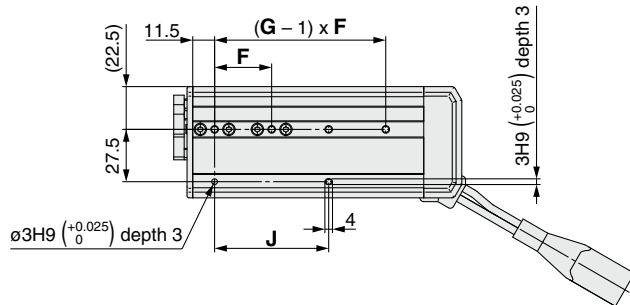
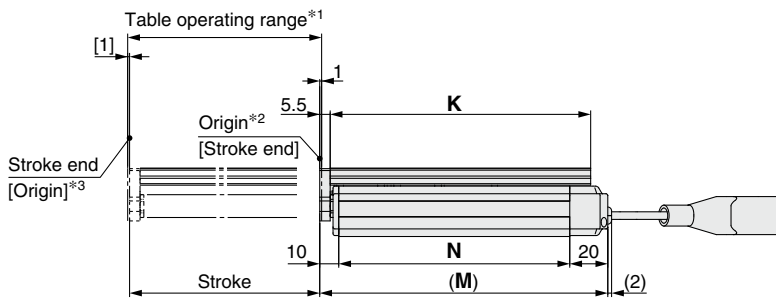
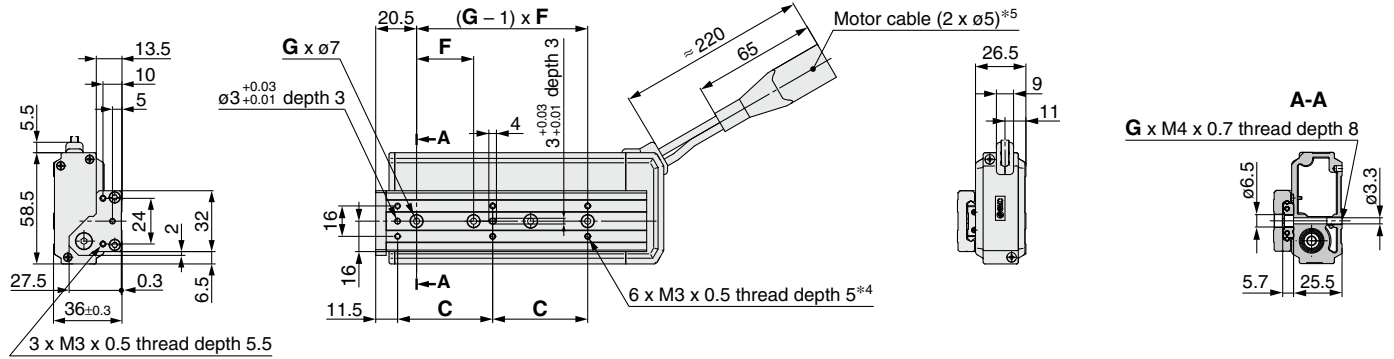

	[mm]						
Model	C	F	G	J	K	M	N
LESH8R□□-50□□-□□□□□	46	29	3	58	111	125.5	95.5
LESH8R□□-75□□-□□□□□	50	30	4	60	137	151.5	121.5

\*1 This is the range within which the table can move when it returns to origin. Make sure that workpieces mounted on the table do not interfere with other workpieces or the facilities around the table.

\*2 Position after returning to origin

\*3 [ ] for when the direction of return to origin has changed

\*4 If workpiece retaining screws are too long, they can touch the guide block and cause a malfunction. Use screws that are between the maximum and minimum screw-in depths in length.

\*5 Secure the motor cable and lock cable so that the cables are not repeatedly bent.



# LESH Series

Incremental (Step Motor 24 VDC)

Incremental (Servo Motor 24 VDC)

## Dimensions: Basic Type/R Type

### LESH16R

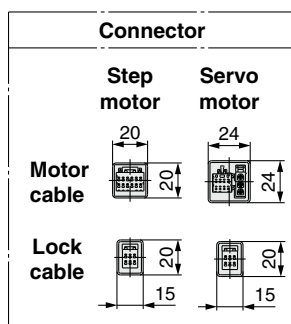
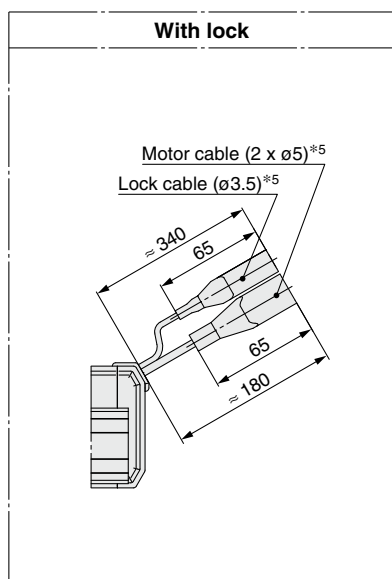
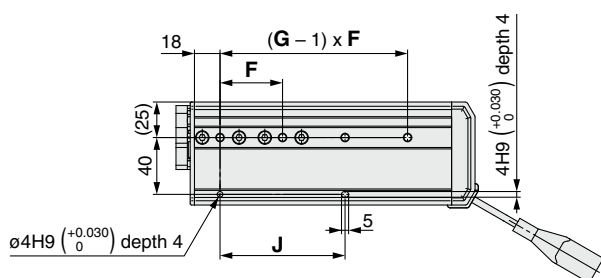
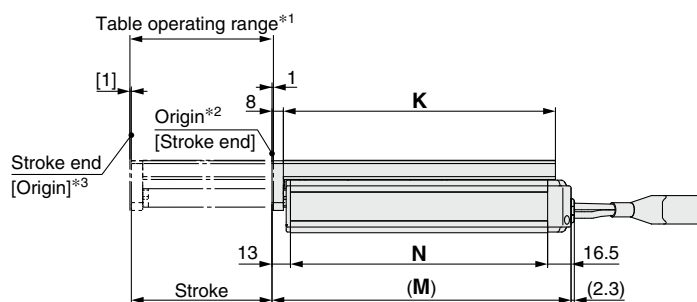
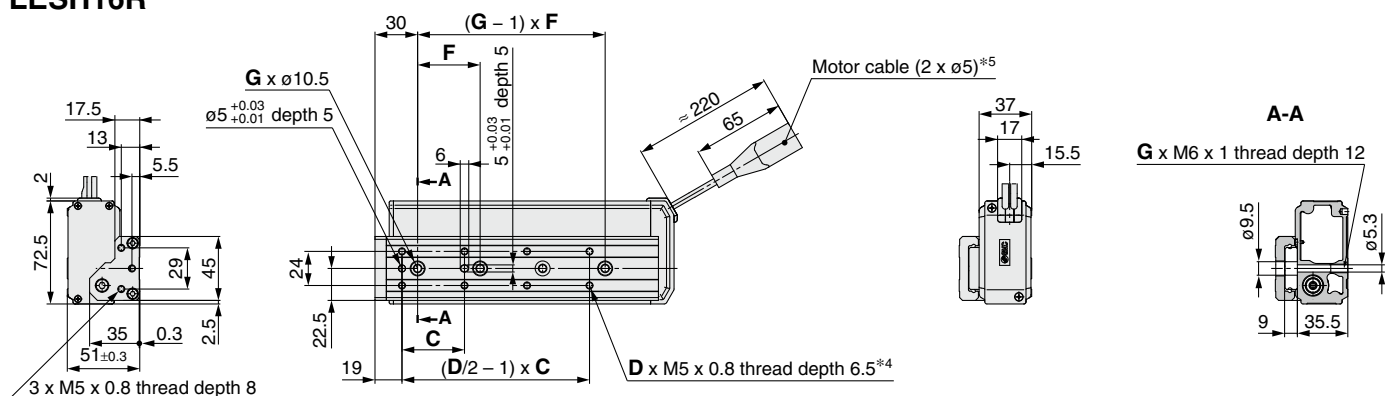

	[mm]							
Model	C	D	F	G	J	K	M	N
LESH16R□□-50□□-□□□□□	40	6	45	2	45	116.5	135.5	106
LESH16R□□-100□□-□□□□□	44	8	44	4	88	191.5	210.5	181

- \*1 This is the range within which the table can move when it returns to origin. Make sure that workpieces mounted on the table do not interfere with other workpieces or the facilities around the table.
- \*2 Position after returning to origin
- \*3 [ ] for when the direction of return to origin has changed
- \*4 If workpiece retaining screws are too long, they can touch the guide block and cause a malfunction. Use screws that are between the maximum and minimum screw-in depths in length.
- \*5 Secure the motor cable and lock cable so that the cables are not repeatedly bent.

## Dimensions: Basic Type/R Type

### LESH25R

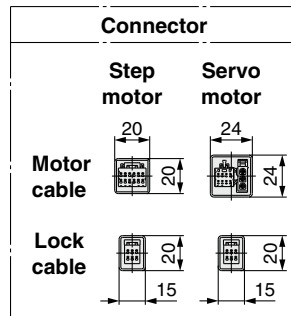
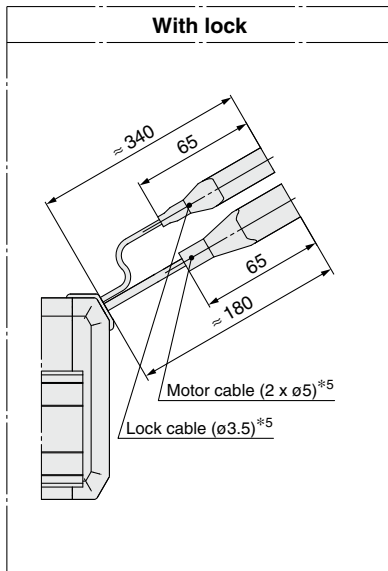
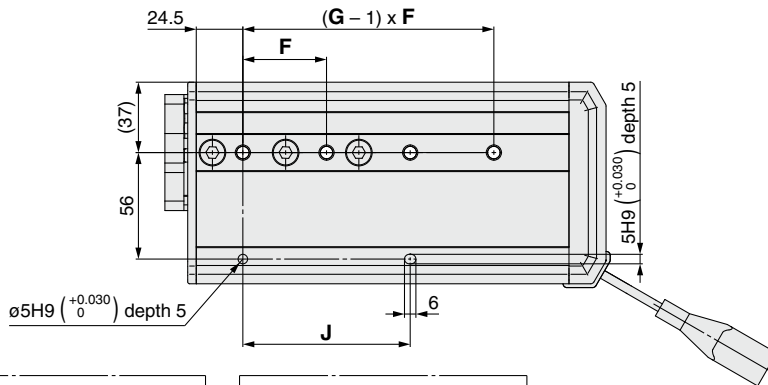
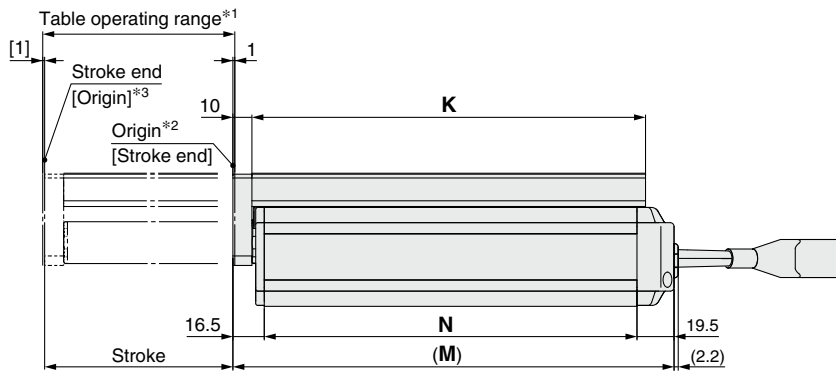
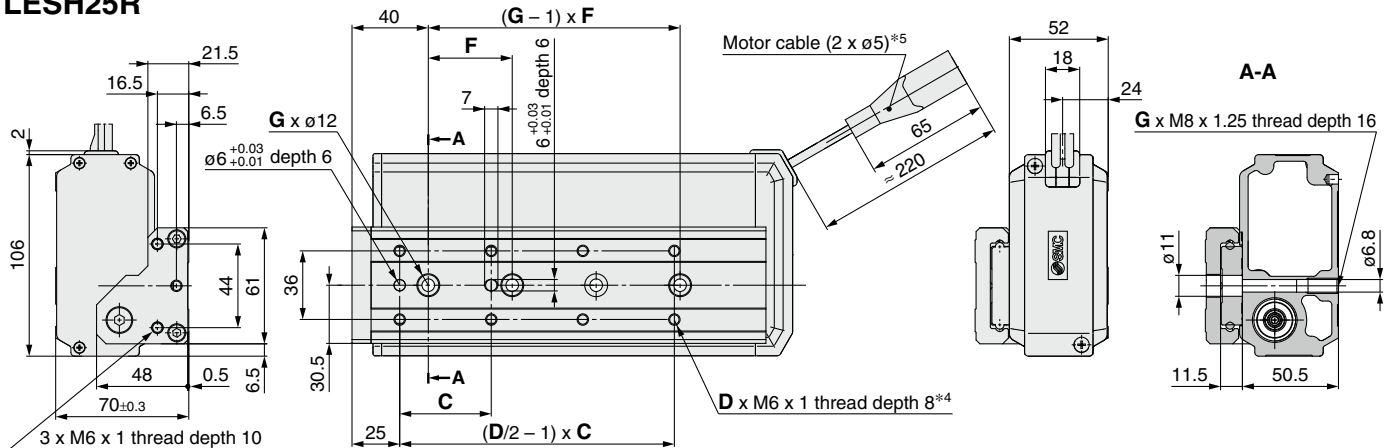

Model	[mm]							
	C	D	F	G	J	K	M	N
LESH25R□□-50□□-□□□□□□	75	4	80	2	80	143	168	132
LESH25R□□-100□□-□□□□□□	48	8	44	4	88	207	232	196
LESH25R□□-150□□-□□□□□□	65	8	66	4	132	285	310	274

\*1 This is the range within which the table can move when it returns to origin. Make sure that workpieces mounted on the table do not interfere with other workpieces or the facilities around the table.  
 \*2 Position after returning to origin  
 \*3 [ ] for when the direction of return to origin has changed  
 \*4 If workpiece retaining screws are too long, they can touch the guide block and cause a malfunction. Use screws that are between the maximum and minimum screw-in depths in length.  
 \*5 Secure the motor cable and lock cable so that the cables are not repeatedly bent.

# LESH Series

Incremental (Step Motor 24 VDC)

Incremental (Servo Motor 24 VDC)

## Dimensions: Symmetrical Type/L Type

### LESH8L

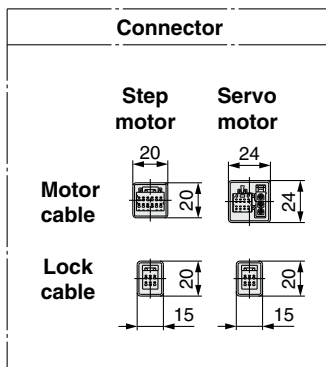
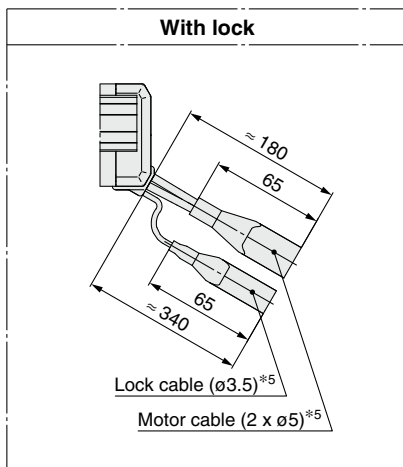
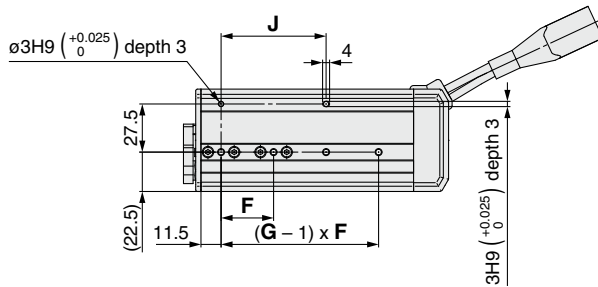
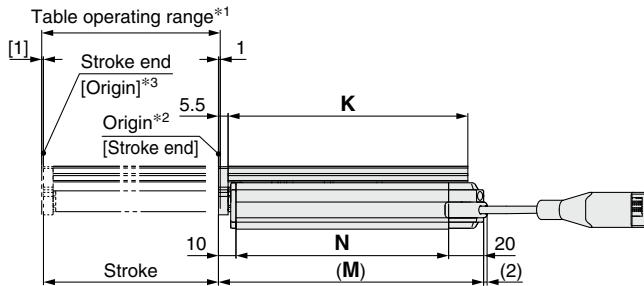
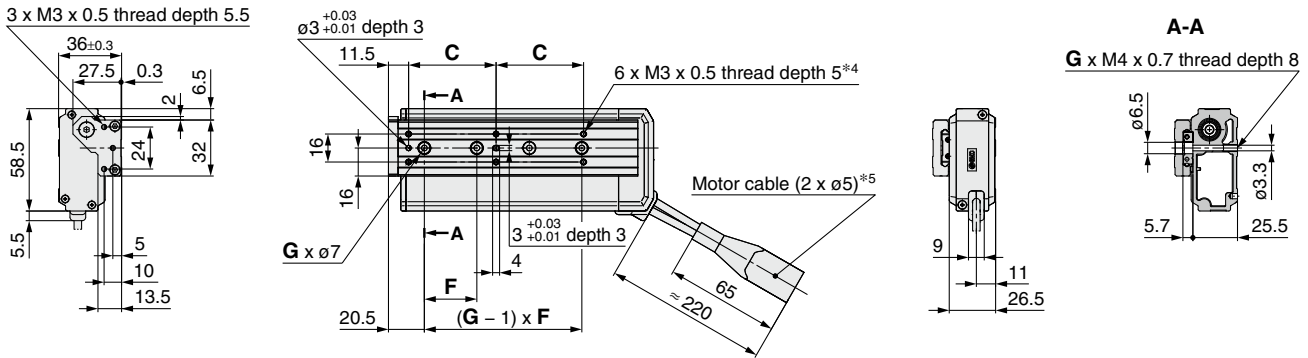

	[mm]						
Model	C	F	G	J	K	M	N
LESH8L□□-50□□-□□□□□	46	29	3	58	111	125.5	95.5
LESH8L□□-75□□-□□□□□	50	30	4	60	137	151.5	121.5

- \*1 This is the range within which the table can move when it returns to origin. Make sure that workpieces mounted on the table do not interfere with other workpieces or the facilities around the table.
- \*2 Position after returning to origin
- \*3 [ ] for when the direction of return to origin has changed
- \*4 If workpiece retaining screws are too long, they can touch the guide block and cause a malfunction. Use screws that are between the maximum and minimum screw-in depths in length.
- \*5 Secure the motor cable and lock cable so that the cables are not repeatedly bent.

## Dimensions: Symmetrical Type/L Type

### LESH16L

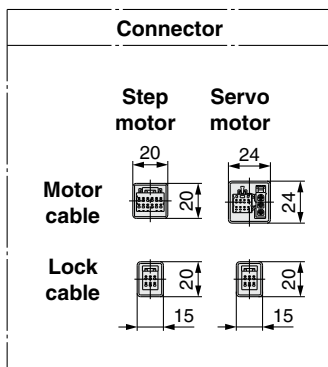
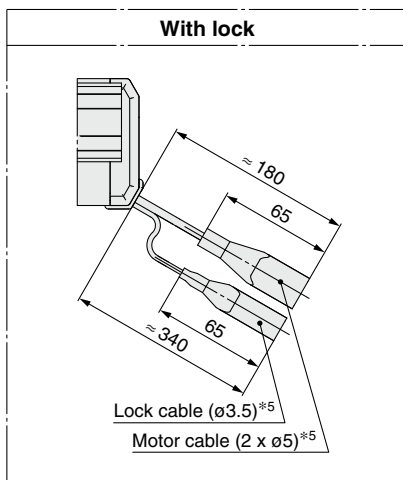
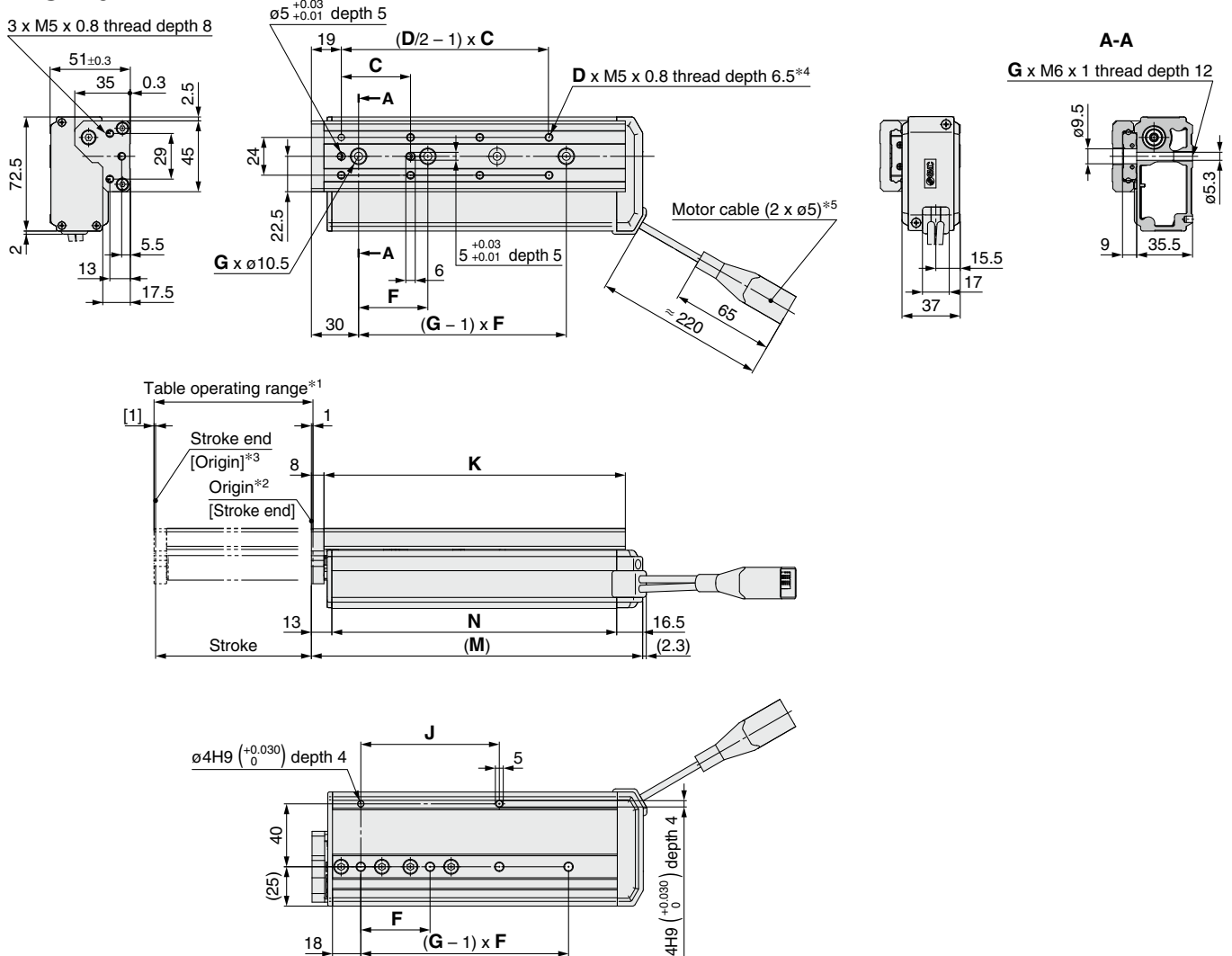

	[mm]							
Model	C	D	F	G	J	K	M	N
LESH16L□□-50□□-□□□□□□	40	6	45	2	45	116.5	135.5	106
LESH16L□□-100□□-□□□□□□	44	8	44	4	88	191.5	210.5	181

- \*1 This is the range within which the table can move when it returns to origin. Make sure that workpieces mounted on the table do not interfere with other workpieces or the facilities around the table.
- \*2 Position after returning to origin
- \*3 [ ] for when the direction of return to origin has changed
- \*4 If workpiece retaining screws are too long, they can touch the guide block and cause a malfunction. Use screws that are between the maximum and minimum screw-in depths in length.
- \*5 Secure the motor cable and lock cable so that the cables are not repeatedly bent.

# LESH Series

Incremental (Step Motor 24 VDC)

Incremental (Servo Motor 24 VDC)

## Dimensions: Symmetrical Type/L Type

### LESH25L

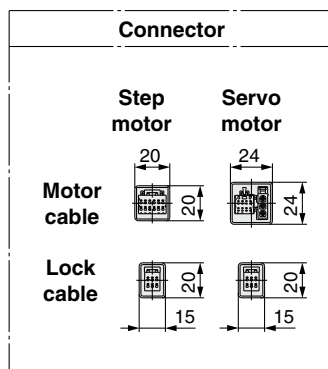
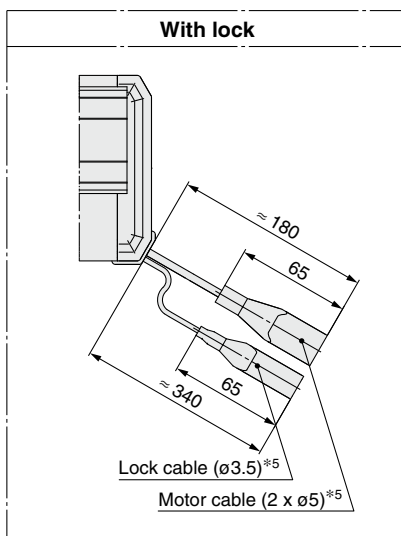
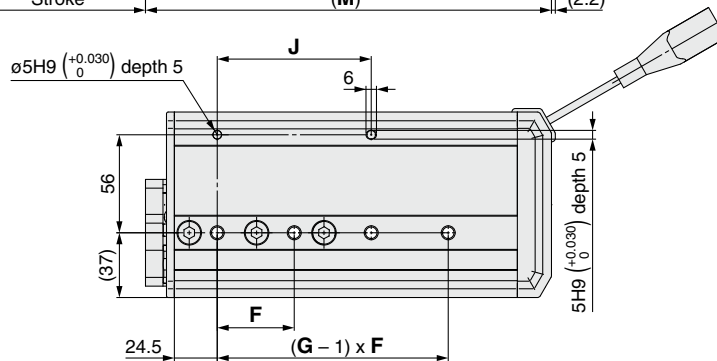
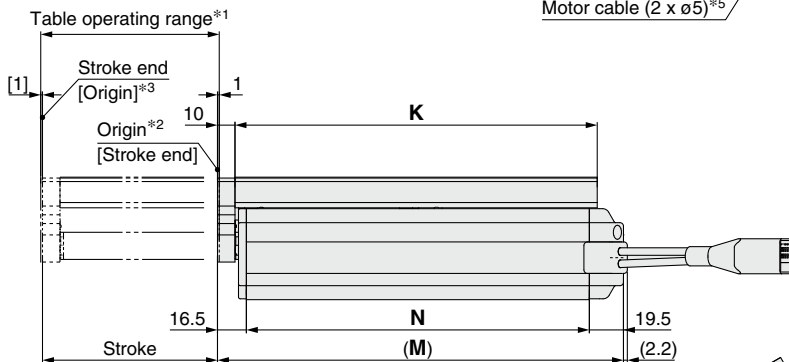
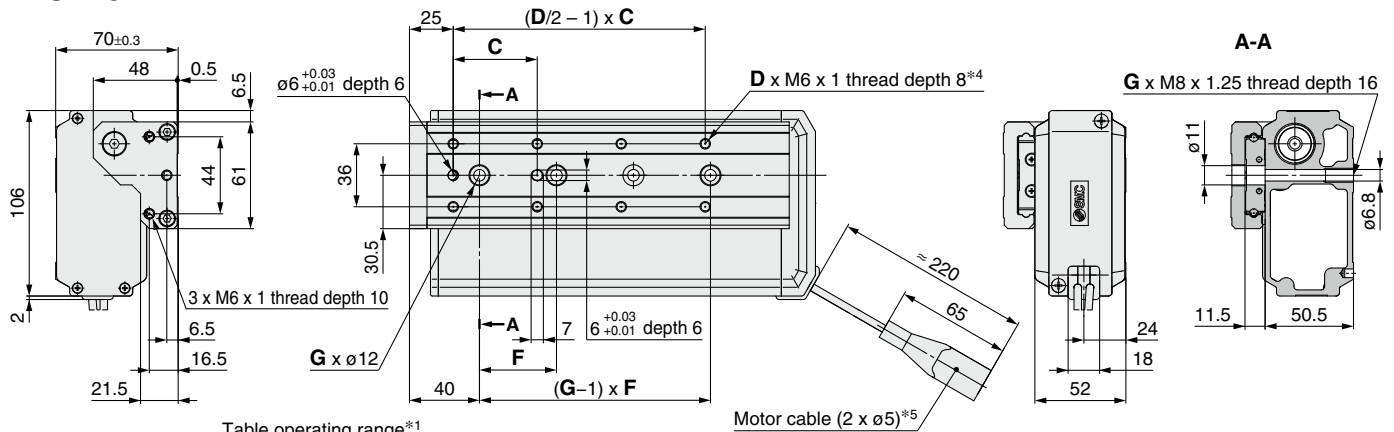

Model	C	D	F	G	J	K	M	N
LESH25L□□-50□□-□□□□	75	4	80	2	80	143	168	132
LESH25L□□-100□□-□□□□	48	8	44	4	88	207	232	196
LESH25L□□-150□□-□□□□	65	8	66	4	132	285	310	274

- \*1 This is the range within which the table can move when it returns to origin. Make sure that workpieces mounted on the table do not interfere with other workpieces or the facilities around the table.
- \*2 Position after returning to origin
- \*3 [ ] for when the direction of return to origin has changed
- \*4 If workpiece retaining screws are too long, they can touch the guide block and cause a malfunction. Use screws that are between the maximum and minimum screw-in depths in length.
- \*5 Secure the motor cable and lock cable so that the cables are not repeatedly bent.

## Dimensions: In-line Motor Type/D Type

### LESH8D

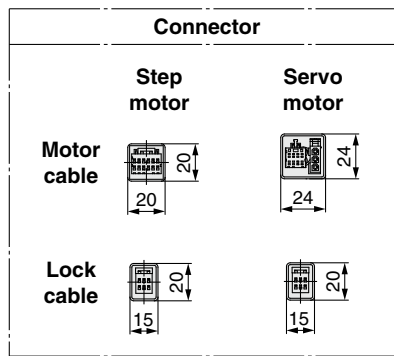
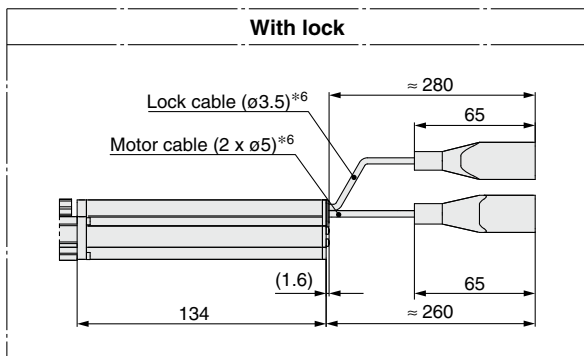
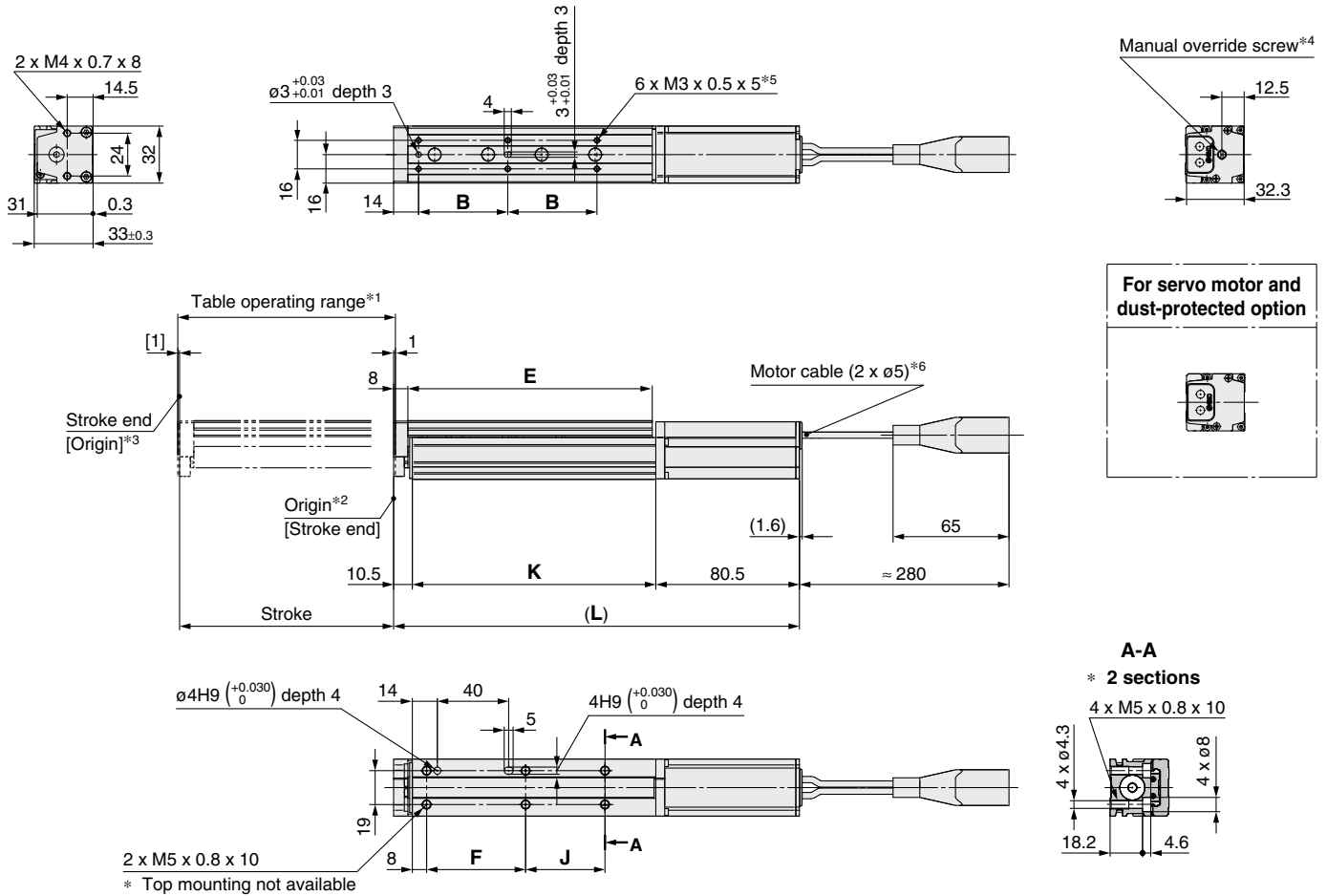

Model	L	B	E	F	J	K
LESH8D□□-50□□-□□□□□□	201.5	46	111	54.5	19.5	110.5
LESH8D□□-50B□□-□□□□□□	255					
LESH8D□□-75□□-□□□□□□	227.5	50	137	55.5	44.5	136.5
LESH8D□□-75B□□-□□□□□□	281					

- \*1 This is the range within which the table can move when it returns to origin. Make sure that workpieces mounted on the table do not interfere with other workpieces or the facilities around the table.
- \*2 Position after returning to origin
- \*3 [ ] for when the direction of return to origin has changed
- \*4 The distance between the motor end cover and the manual override screw is up to 16 mm. The motor end cover hole size is ø5.5.
- \*5 If workpiece retaining screws are too long, they can touch the guide block and cause a malfunction. Use screws that are between the maximum and minimum screw-in depths in length.
- \*6 Secure the motor cable and lock cable so that the cables are not repeatedly bent.

# LESH Series

Incremental (Step Motor 24 VDC)

Incremental (Servo Motor 24 VDC)

## Dimensions: In-line Motor Type/D Type

### LESH16D

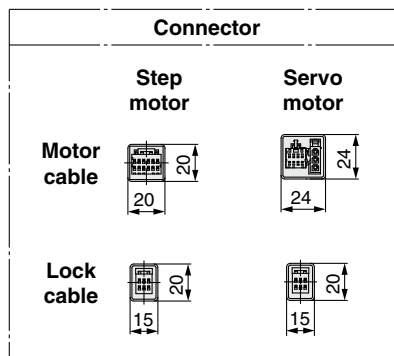
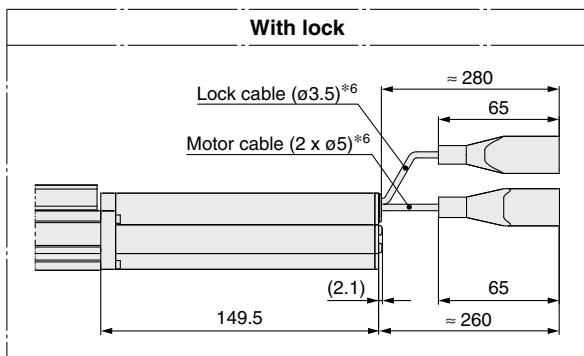
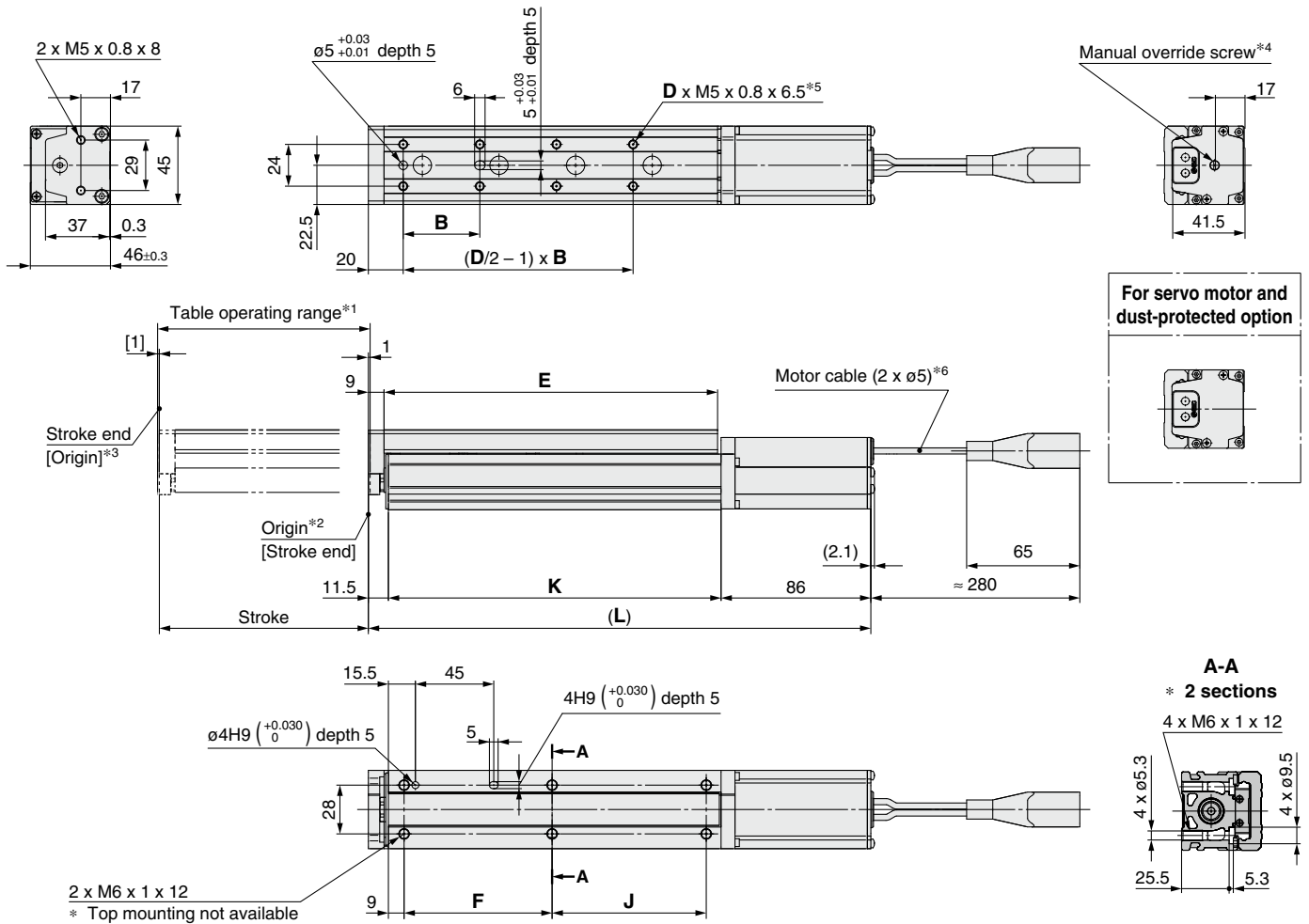

Model	L	B	D	E	F	J	K
LESH16D□□-50□□-□□□□□□	219.5	40	6	116.5	65	39.5	122
LESH16D□□-50B□□-□□□□□□	283						
LESH16D□□-100□□-□□□□□□	288.5	44	8	191.5	85	88.5	191
LESH16D□□-100B□□-□□□□□□	352						

- \*1 This is the range within which the table can move when it returns to origin. Make sure that workpieces mounted on the table do not interfere with other workpieces or the facilities around the table.
- \*2 Position after returning to origin
- \*3 [ ] for when the direction of return to origin has changed
- \*4 The distance between the motor end cover and the manual override screw is up to 17 mm. The motor end cover hole size is ø5.5.
- \*5 If workpiece retaining screws are too long, they can touch the guide block and cause a malfunction. Use screws that are between the maximum and minimum screw-in depths in length.
- \*6 Secure the motor cable and lock cable so that the cables are not repeatedly bent.

## Dimensions: In-line Motor Type/D Type

### LESH25D

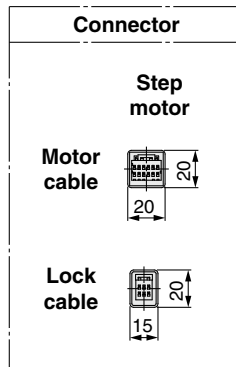
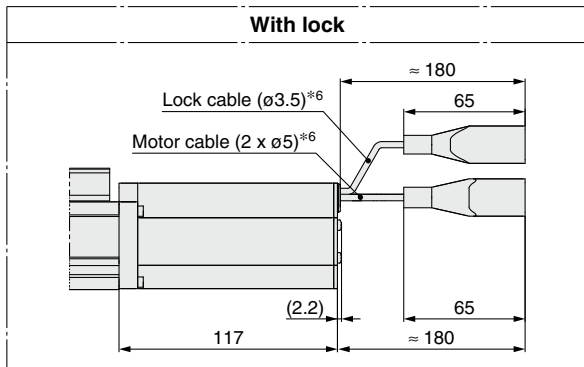
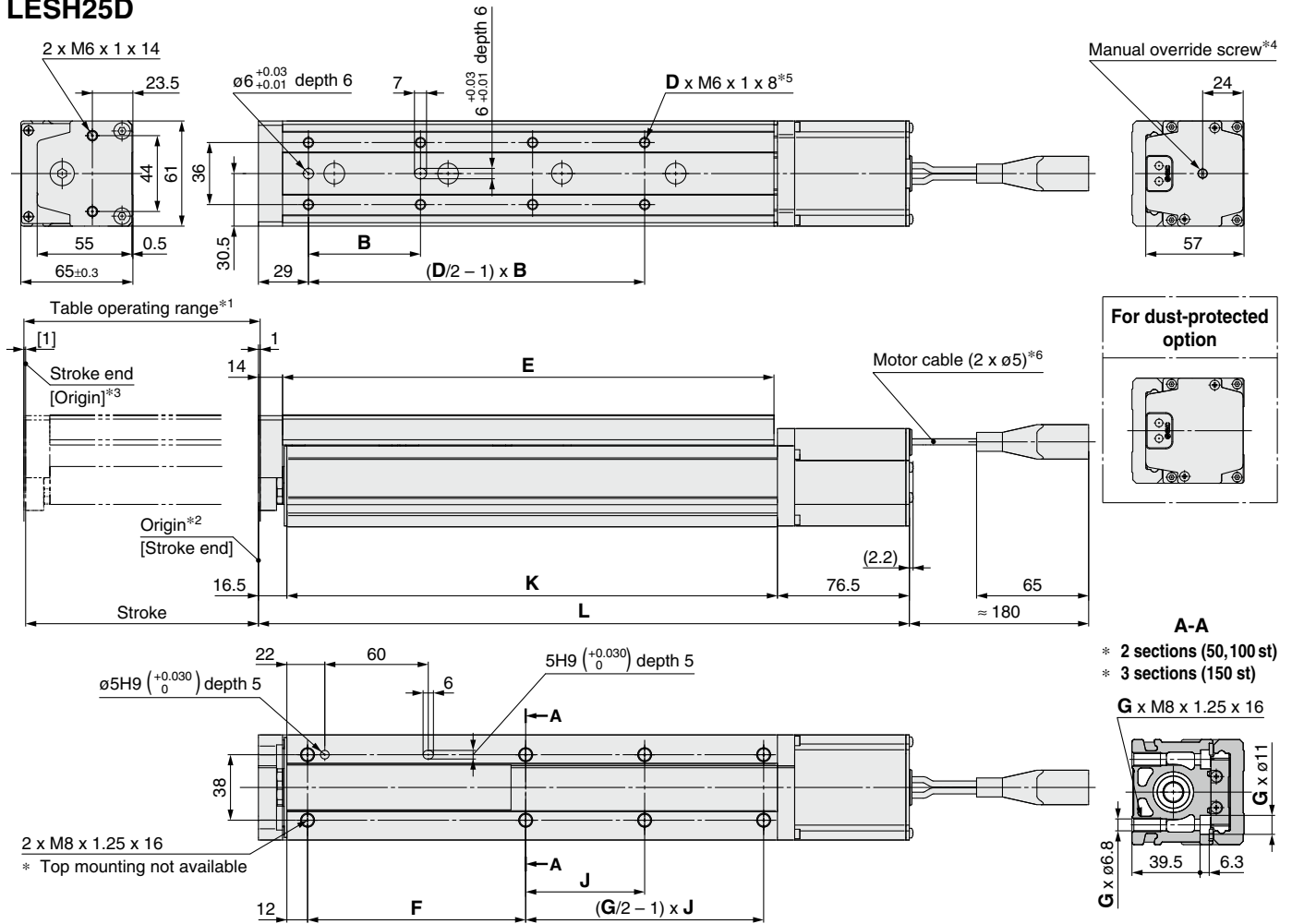

[mm]

Model	L	B	D	E	F	G	J	K
LESH25D□-50□□-□□□□□□	237.5	75	4	143	84		40.5	144.5
LESH25D□-50B□□-□□□□□□	278							
LESH25D□-100□□-□□□□□□	299.5	48	8	207	98.5	4	88	206.5
LESH25D□-100B□□-□□□□□□	340							
LESH25D□-150□□-□□□□□□	377.5	65		285	126.5	6	69	284.5
LESH25D□-150B□□-□□□□□□	418							

- \*1 This is the range within which the table can move when it returns to origin. Make sure that workpieces mounted on the table do not interfere with other workpieces or the facilities around the table.
- \*2 Position after returning to origin
- \*3 [ ] for when the direction of return to origin has changed
- \*4 The distance between the motor end cover and the manual override screw is up to 4 mm.  
The motor end cover hole size is ø5.5.
- \*5 If workpiece retaining screws are too long, they can touch the guide block and cause a malfunction.  
Use screws that are between the maximum and minimum screw-in depths in length.
- \*6 Secure the motor cable and lock cable so that the cables are not repeatedly bent.



# LESH Series

Incremental (Step Motor 24 VDC)

Incremental (Servo Motor 24 VDC)

## Side Holder (In-line Motor Type/D Type)

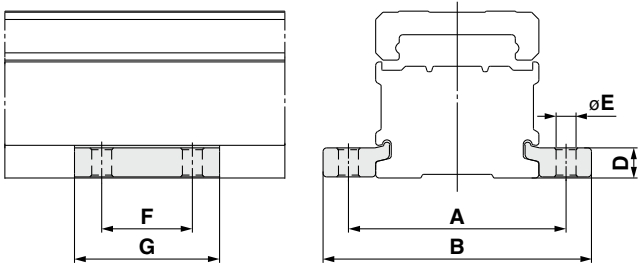

Part no.*1	A	B	D	E	F	G	Applicable model
LE-D-3-1	45	57.6	6.7	4.5	20	33	LESH8D
LE-D-3-2	60	74	8.3	5.5	25	40	LESH16D
LE-D-3-3	81	99	12	6.6	30	49	LESH25D

\*1 Part numbers for 1 side holder



# LES/LESH Series Specific Product Precautions 1

Be sure to read this before handling the products. Refer to page 1351 for safety instructions and pages 1352 to 1357 for electric actuator precautions.

## Design

### ⚠ Caution

- 1. Do not apply a load in excess of the specification limits.**  
Select a suitable actuator by work load and allowable moment. If the product is used outside of the specification limits, the eccentric load applied to the guide will be excessive and have adverse effects such as the generation of play on the guide, reduced accuracy, reduced service life of the product.
- 2. Do not use the product in applications where excessive external force or impact force is applied to it.**  
This can cause a malfunction.

## Handling

### ⚠ Caution

- 1. INP output signal**
  - 1) Positioning operation  
When the product comes within the set range of the step data [In position], the INP output signal will turn ON.  
Initial value: Set to [0.50] or higher.
  - 2) Pushing operation  
When the effective force exceeds the step data [Trigger LV], the INP output signal will turn ON. Use the product within the specified range of the [Pushing force] and [Trigger LV].  
To ensure that the actuator pushes the workpieces with the set [Pushing force], it is recommended that the [Trigger LV] be set to the same value as the [Pushing force].
- 2. When the pushing operation is used, be sure to set to [Pushing operation]. Never allow the table to collide with the stroke end except during return to origin.**  
When incorrect instructions are inputted, such as those which cause the product to operate outside of the specification limits or outside of the actual stroke through changes in the controller/driver settings and/or origin position, the table may collide with the stroke end of the actuator. Be sure to check these points before use.  
If the table collides with the stroke end of the actuator, the guide, belt, or internal stopper may break. This can result in abnormal operation.

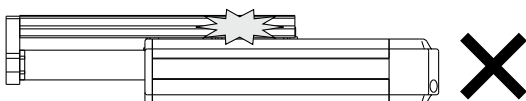

Handle the actuator with care when it is used in the vertical direction as the workpiece will fall freely from its own weight.

### 3. Use the product with the following moving force.

- Step motor (Servo/24 VDC): 100%
- Servo motor (24 VDC) : 250%

If the moving force is set below the values above, it may cause the generation of an alarm.

## Handling

### ⚠ Caution

- 4. The actual speed of this actuator is affected by the load.**  
Check the model selection section of the catalog.
- 5. Do not apply a load, impact, or resistance in addition to the transferred load during return to origin.**  
Additional force will cause the displacement of the origin position since it is based on the detected motor torque.
- 6. The table and guide block are made of special stainless steel, but can rust in an environment where droplets of water adhere to it.**
- 7. Do not dent, scratch, or cause other damage to the body, table and end plate mounting surfaces.**  
Doing so may cause unevenness in the mounting surface, play in the guide, or an increase in the sliding resistance.
- 8. Do not dent, scratch or cause other damage to the surface over which the rail and guide will move.**  
Doing so may cause play or an increase in the sliding resistance.
- 9. Do not apply strong impact or an excessive moment while mounting a workpiece.**  
If an external force over the allowable moment is applied, it may cause play in the guide or an increase in the sliding resistance.
- 10. Keep the flatness of mounting surface within 0.02 mm.**  
If a workpiece or base does not sit evenly on the body of the product, play in the guide or an increase in the sliding resistance may occur. Do not deform the mounting surface by mounting with workpieces tucked in.
- 11. Do not drive the main body with the table fixed.**
- 12. When mounting the product, for R/L type fixed cable, keep the following dimension or more for bends in the cable. For D type, keep a 40 mm or longer diameter for bends in the cable.**

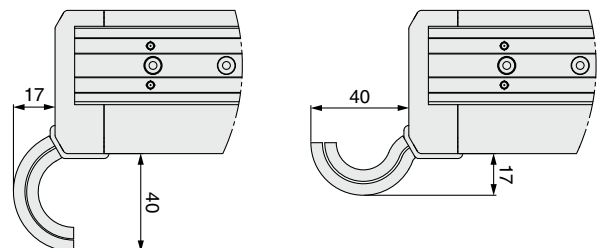



# LES/LESH Series Specific Product Precautions 2

Be sure to read this before handling the products. Refer to page 1351 for safety instructions and pages 1352 to 1357 for electric actuator precautions.

## Handling

### Caution

#### 13. When mounting the product, use screws of adequate length and tighten them to the maximum torque or less.

Tightening the screws with a higher torque than recommended may result in a malfunction, while tightening with a lower torque can result in the displacement of the mounting position or, in extreme conditions, the actuator could become detached from its mounting position.

Model	Screw size	Max. tightening torque [N·m]	L (Max. screw-in depth) [mm]
LES□8R/L	M4 x 0.7	1.5	8
LES□8D	M5 x 0.8	3	10
LES16R/L			
LES16D	M6 x 1	5.2	12
LESH16□			
LES25R/L			
LES25D	M8 x 1.25	10	16
LESH25□			

Model	Screw size	Max. tightening torque [N·m]	L [mm]
LES8R/L	M3 x 0.5	0.63	23.5
LESH8R/L			25.5
LES□8D	M4 x 0.7	1.5	18.2
LES16R/L			33.5
LES16D			25.2
LESH16R/L	M5 x 0.8	3	35.5
LESH16D			25.5
LES25R/L			49
LES25D	M6 x 1	5.2	39.8
LESH25R/L			50.5
LESH25D			39.5

Model	Screw size	Max. tightening torque [N·m]	L [mm]
LES8R/L	M3 x 0.5	0.63	6
LESH8R/L			5.5
LES□8D	M4 x 0.7	1.5	8
LES16R/L			
LES16D			
LESH16□	M5 x 0.8	3	12
LES25R/L			
LESH25R/L			
LES□25D	M6 x 1	5.2	14

To prevent the workpiece retaining screws from penetrating the end plate, use screws that are 0.5 mm or shorter than the maximum screw-in depth. If long screws are used, they may touch the end plate and cause a malfunction.

Model	Screw size	Max. tightening torque [N·m]	L (Min. to Max. screw-in depth) [mm]
LES8□	M3 x 0.5	0.63	2.1 to 4.1
LESH8□			5 (Max.)
LES16□	M4 x 0.7	1.5	2.7 to 5.7
LESH16□			6.5 (Max.)
LES25□	M5 x 0.8	3	3.3 to 7.3
LESH25□			8 (Max.)

To prevent the workpiece retaining screws from touching the guide block, use screws that are the maximum screw-in depth or less. If long screws are used, they may touch the guide block and cause a malfunction.

#### Body fixed/Side mounting (Side holder)

Model	Screw size	Max. tightening torque [N·m]	L [mm]
LES□8D	M4 x 0.7	1.5	6.7
LES□16D	M5 x 0.8	3	8.3
LES□25D	M6 x 1	5.2	12

When using the side holders to install the actuator, be sure to use the positioning pin. It can be displaced when vibration or excessive external force is applied.

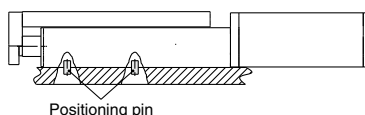

Positioning pin

#### 14. For pushing operations, set the product to a position at least 0.5 mm away from a workpiece. (This position is referred to as the pushing start position.)

The following alarms may be generated and operation may become unstable if the product is set to the same position as a workpiece.

##### a. "Posn failed"

The product cannot reach the pushing start position due to variations in the width of workpieces.

##### b. "Pushing ALM"

The product is pushed back from the pushing start position after starting to push.

#### 15. When external force is to be applied to the table, it is necessary to reduce the work load for the sizing.

When a cable duct or flexible moving tube is attached to the actuator, the sliding resistance of the table will increase, which may lead to the malfunction of the product.

#### 16. When using the side holders to install the actuator, use within the following dimension range.

Otherwise, installation balance will deteriorate and cause loosening.

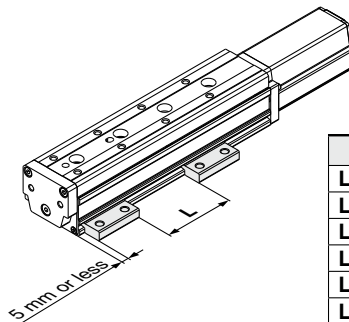

Model	L [mm]
LES□8D□-30	5 to 10
LES□8D□-50	20 to 30
LES□8D□-75	50 to 60
LES□16D□-30	5 to 10
LES□16D□-50	20 to 30
LES□16D□-75	60 to 75
LES□16D□-100	85 to 100
LES□25D□-30	5 to 15
LES□25D□-50	25 to 35
LES□25D□-75	60 to 75
LES□25D□-100	70 to 100
LES□25D□-125	155 to 170
LES□25D□-150	160 to 180

#### 17. For the LES□□D, do not grasp or peel off a masking tape on the bottom of the body.

The masking tape may peel off and foreign matter may get inside the actuator.

#### 18. For the LES□□D, a gap will form between the motor flange and table when the table moves (marked with the arrow below). Be careful not to put hands or fingers in a gap.

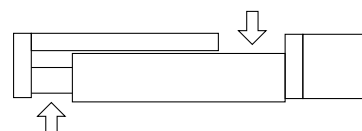



# LES/LESH Series Specific Product Precautions 3

Be sure to read this before handling the products. Refer to page 1351 for safety instructions and pages 1352 to 1357 for electric actuator precautions.

## Handling

### ⚠ Caution

19. When mounting the body with through-holes in the following mounting orientations, make sure to use two side holders as shown in the figures.

Otherwise, installation balance will deteriorate and cause loosening.

Bottom mounting

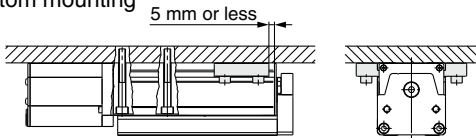

Wall mounting

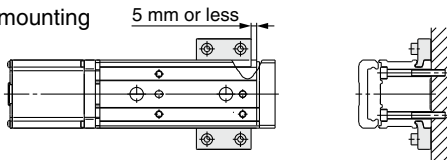

Vertical mounting

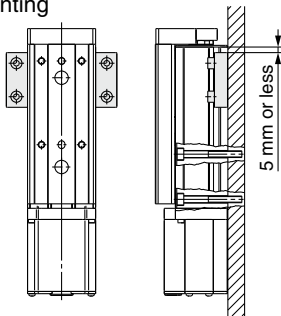

20. Install the body as shown below with the ○.

Since the product support becomes unstable, it may cause a malfunction, noise or an increase in the deflection.

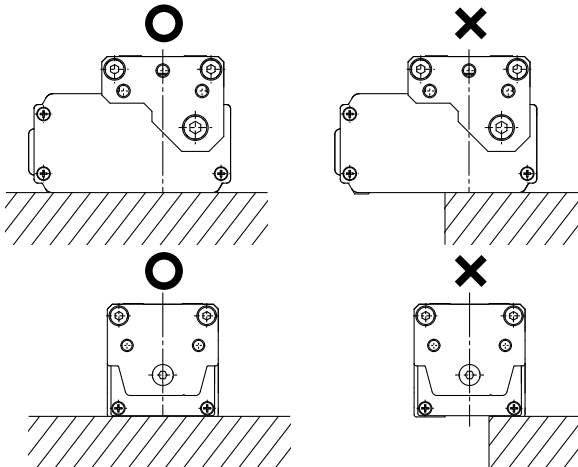

21. Even with the same product number, the table of some products can be moved by hand and the table of some products cannot be moved by hand. However, there is no abnormality with these products. (Without lock)

This difference is caused because there is a little variation with the positive efficiency (when the table is moved by the motor) and there is a large variation with the reverse-efficiency (when the table is moved manually) due to the product characteristics. There is hardly any difference among products when they are operated by the motor.

## Handling

### ⚠ Caution

22. For LES□□□<sup>R</sup>, remove the cap and operate the manual override screw with a hexagon wrench.

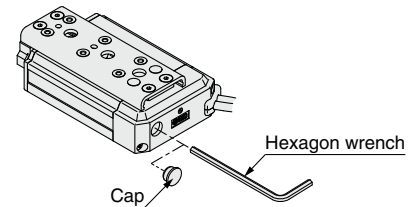

## Maintenance

### ⚠ Warning

1. Ensure that the power supply is stopped before starting maintenance work or replacement of the product.
2. For lubrication, wear protective glasses.
3. Perform maintenance according to the following requirements.

#### Maintenance frequency

Perform maintenance according to the table below.

Frequency	Appearance check	Belt check
Inspection before daily operation	○	—
Inspection every 6 months*1	—	○
Inspection every 250 km*1	—	○
Inspection every 5 million cycles*1	—	○

\*1 Select whichever comes first.

#### • Items for visual appearance check

1. Loose set screws, Abnormal amount of dirt, etc.
2. Check for visible damage, Check of cable joint
3. Vibration, Noise

#### • Items for belt check (R/L type only)

Stop operation immediately and replace the belt when any of the following occur.

- a. **Tooth shape canvas is worn out**  
Canvas fiber becomes fuzzy, Rubber is coming off and the fiber has become whitish, Lines of fibers have become unclear
- b. **Peeling off or wearing of the side of the belt**  
Belt corner has become rounded and frayed threads stick out
- c. **Belt partially cut**  
Belt is partially cut, Foreign matter caught in the teeth of other parts is causing damage
- d. **A vertical line on belt teeth is visible**  
Damage which is made when the belt runs on the flange
- e. **Rubber back of the belt is softened and sticky**
- f. **Cracks on the back of the belt are visible**



# LES/LESH Series

## Battery-less Absolute Encoder Type Specific Product Precautions

Be sure to read this before handling the products. Refer to page 1351 for safety instructions and pages 1352 to 1357 for electric actuator precautions.

### Handling

#### ⚠ Caution

##### 1. Absolute encoder ID mismatch error at the first connection

In the following cases, an "ID mismatch error" alarm occurs after the power is turned ON. Perform a return to origin operation after resetting the alarm before use.

- When an electric actuator is connected and the power is turned ON for the first time after purchase\*1
- When the actuator or motor is replaced
- When the controller is replaced

\*1 If you have purchased an electric actuator and controller with the set part number, the pairing may have already been completed and the alarm may not be generated.

##### "ID mismatch error"

Operation is enabled by matching the encoder ID on the electric actuator side with the ID registered in the controller. This alarm occurs when the encoder ID is different from the registered contents of the controller. By resetting this alarm, the encoder ID is registered (paired) to the controller again.

When a controller is changed after pairing is completed				
	Encoder ID no. (* Numbers below are examples.)			
Actuator	17623	17623	17623	17623
Controller	17623	17699	17699	17623
ID mismatch error occurred?	No	Yes	Error reset ⇒ No	

##### 2. In environments where strong magnetic fields are present, use may be limited.

A magnetic sensor is used in the encoder. Therefore, if the actuator motor is used in an environment where strong magnetic fields are present, malfunction or failure may occur. Do not expose the actuator motor to magnetic fields with a magnetic flux density of 1 mT or more.

When installing an electric actuator and an air cylinder with an auto switch (ex. CDQ2 series) or multiple electric actuators side by side, maintain a space of 40 mm or more around the motor. Refer to the construction drawing of the actuator motor.

##### 3. The connector size of the motor cable is different from that of the electric actuator with an incremental encoder.

The motor cable connector of an electric actuator with a battery-less absolute encoder is different from that of an electric actuator with an incremental encoder. As the connector cover dimensions are different, take the dimensions below into consideration during the design process.

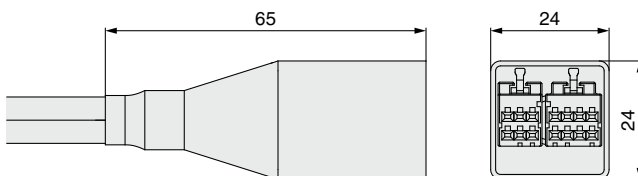

Battery-less absolute encoder connector cover dimensions