

Cylinder Positioner IP200 Series

- Servo-mechanism allows precise and stable position control of cylinders.
- Can be used as a cylinder position control unit for general industrial machines.

How to Order

IP200 - **100**

• Applicable stroke

25 to 300 mm

* Manufacture of strokes in 1 mm increments is possible.

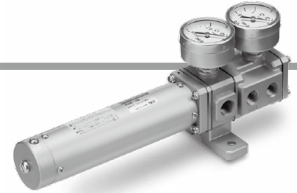

Specifications (No load) Note 1)

Supply pressure	0.3 to 0.7 MPa
Input pressure	0.02 to 0.1 MPa
Applicable bore size	ø50 or more
Applicable stroke	25 to 300 mm or less
Sensitivity <small>Note 2)</small>	Within 0.5% F.S.
Linearity <small>Note 2)</small>	Within ±2% F.S.
Hysteresis <small>Note 2)</small>	Within 1% F.S.
Repeatability <small>Note 2)</small>	Within ±1% F.S.
Air consumption <small>Note 3)</small>	18 L/min (ANR) or less (SUP = 0.5 MPa)
Influence by change in supply pressure	Within 1% F.S./0.05 MPa
Ambient and fluid temperature	-5°C to 60°C
Port size	Rc1/4 (Gauge port Rc1/8)
Weight	Approx. 700 g (at 100 mm stroke)

Replacement Parts

Part no.	Description	Note
IP200-02	Pilot valve unit	
39020-23	Seal kit	Ambient temperature: Standard (-5° to 60°)

Note 1) Specification values are given at normal temperature (20°C).

Note 2) Characteristics relating to accuracy differ depending on combination with other constituent loop equipment, such as positioners and actuators.

Note 3) Air consumption is due to exhaust from nozzle. And (ANR) indicates JIS B0120 standard air.

Construction/Principle of Operation

When signal pressure enters input chamber ①, the input diaphragm ③ is deflected left. Clearance of the nozzle ⑥ is reduced causing higher back pressure at diaphragm A ⑦. This diaphragm A ⑦ has larger area than diaphragm B ⑧ resulting in movement of the spool to the left. Supply pressure then flows to OUT1 ① and partial exhaust from OUT2 ② takes place resulting in cylinder rod ⑤ movement to the right. The movement is linked via connecting rod ④ and feedback spring ② to the input diaphragm ③ balancing the higher pressure. When this occurs nozzle ⑥ clearance increases allowing centralizing of the spool ⑨ to take place. This holds the piston rod in the new position. Input signal increase results in proportional movement of the piston rod.

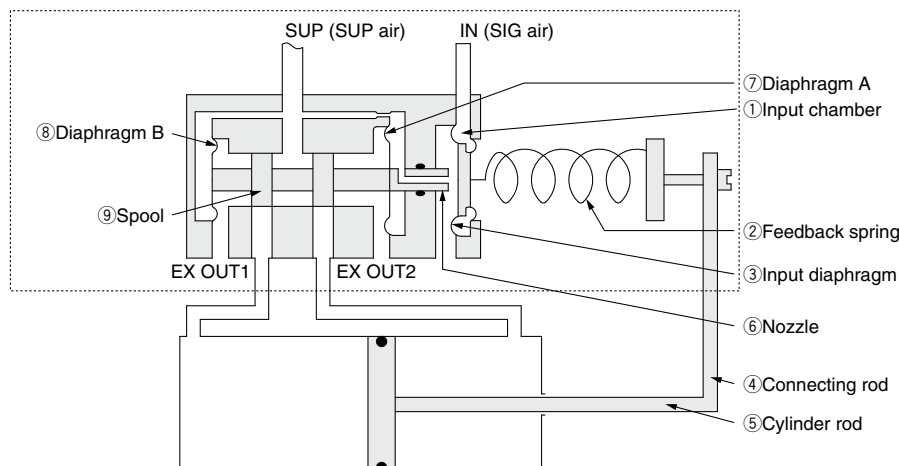

Dimensions

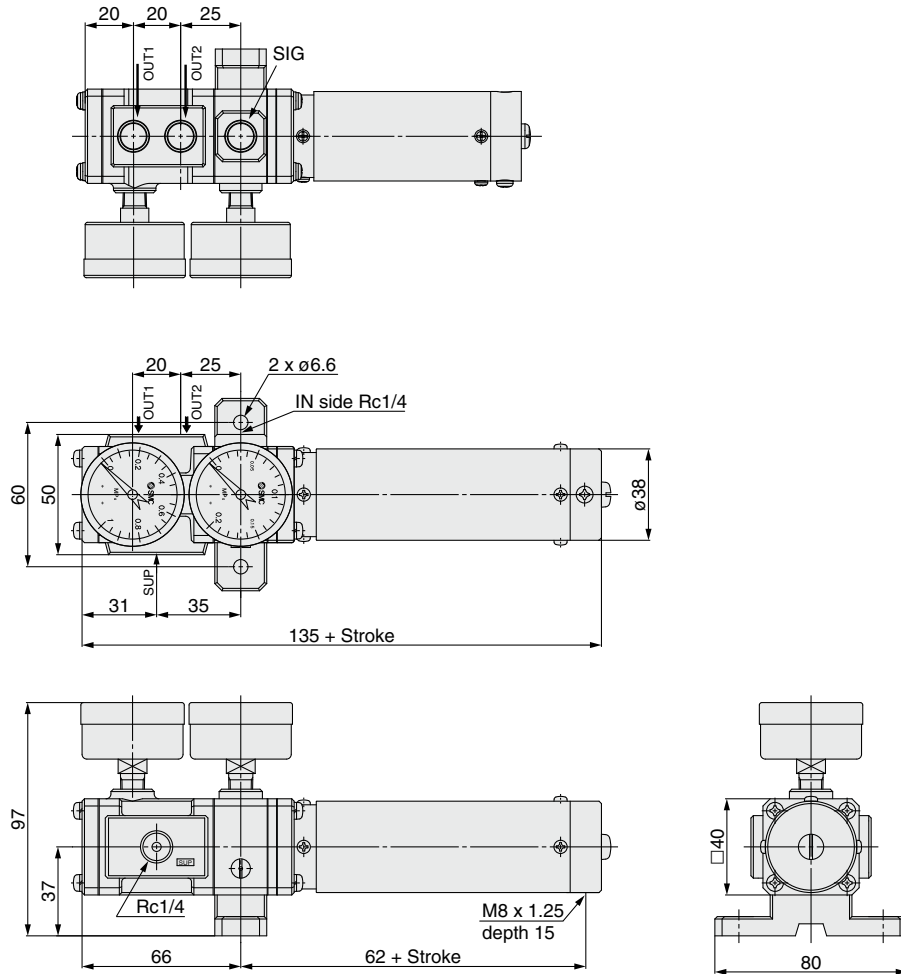

⚠ Precautions

Caution

⚠ Caution

1. As the positioner contains extra-fine orifices such as restrictor and nozzle, if drain or dust is present in the supply pressure line, malfunction (*1) may result. In addition to an air filter (SMC AF series), it is recommended to use a mist separator (SMC AM, AFM series) and a micro mist separator (SMC AMD, AFD series).
Also, refer to "SMC Air Preparation System" for air quality.
2. Never use a lubricator, as this can cause a malfunction (*1).
3. Be sure to flush the piping to prevent foreign matter from entering the positioner before connecting them.

*1 If the restrictor is clogged, the cylinder rod may not perform a stroke or hunching and overshoot may occur.