

Energy Saving, Exhaust-Recovery Booster Regulator

New

Size 10, 20



**CO₂ emissions
(Air consumption)**

Max. 40% reduction*¹

*¹ Based on SMC's measuring conditions

3-piston construction

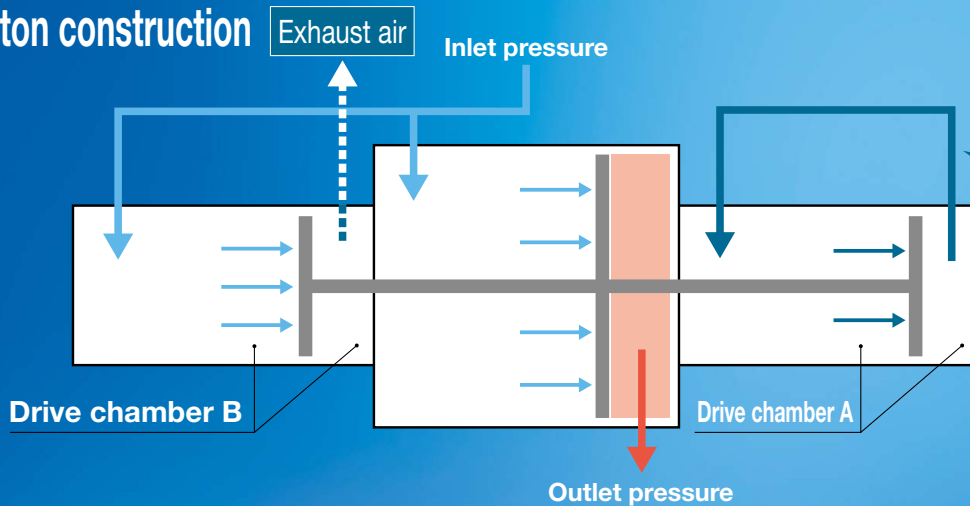

Driven by reusing the exhaust air

Increase factory air pressure by **1.7 times**

Air-only operation that requires no power supply, and allows for easy installation.

Operation noise: **65 dB (A)** * Based on SMC's measuring conditions
* For size 10

15 dB (A) reduction compared with the existing model (VBA series)

- Exhaust noise: Reduced noise due to the exhaust of reused low-pressure air
- Metal noise: Reduced noise due to the adoption of a construction in which the internal switching part does not come into contact with any metal parts

Operating cycles: **50 million** cycles or more

Reduced maintenance frequency due to improved life

* Based on SMC's test conditions

Charging time: Max. **50% shorter**

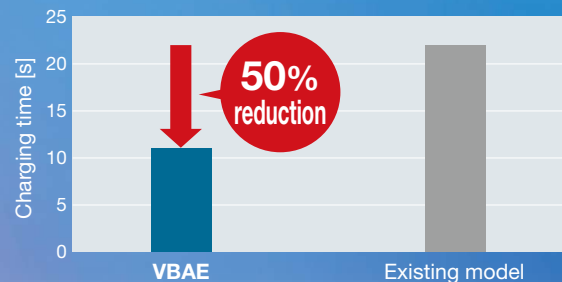

* Inlet pressure: 0.4 MPa, Air tank: 10 L
* For size 20

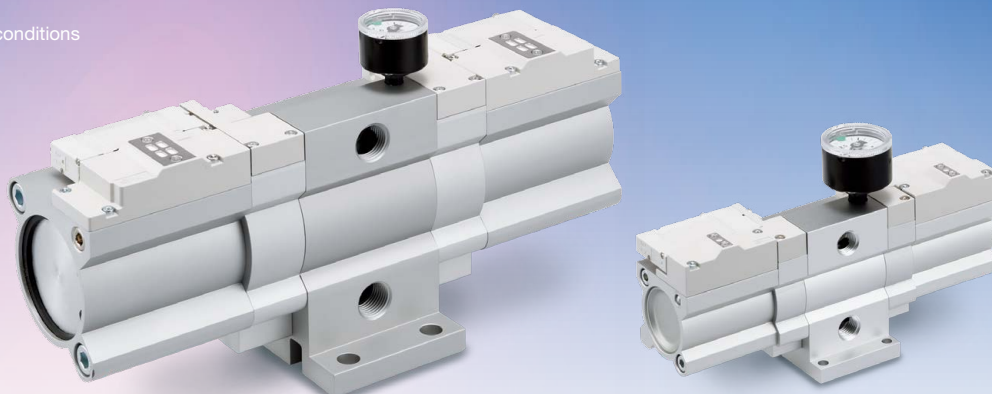

VBAE Series



CAT.ES11-123A

Simple, compact shape

- Built-in silencer
- No longer any need for a pressure regulator knob due to the fixed pressure increase ratio.
More compact than the existing model

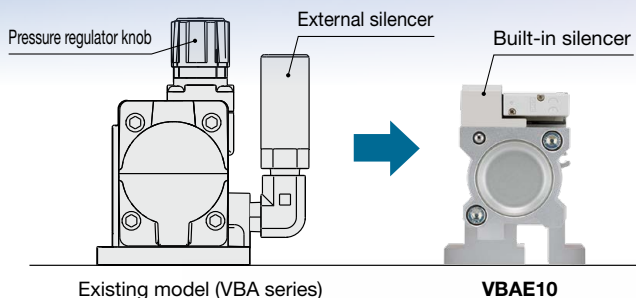

A pressure gauge can be mounted (OUT side).

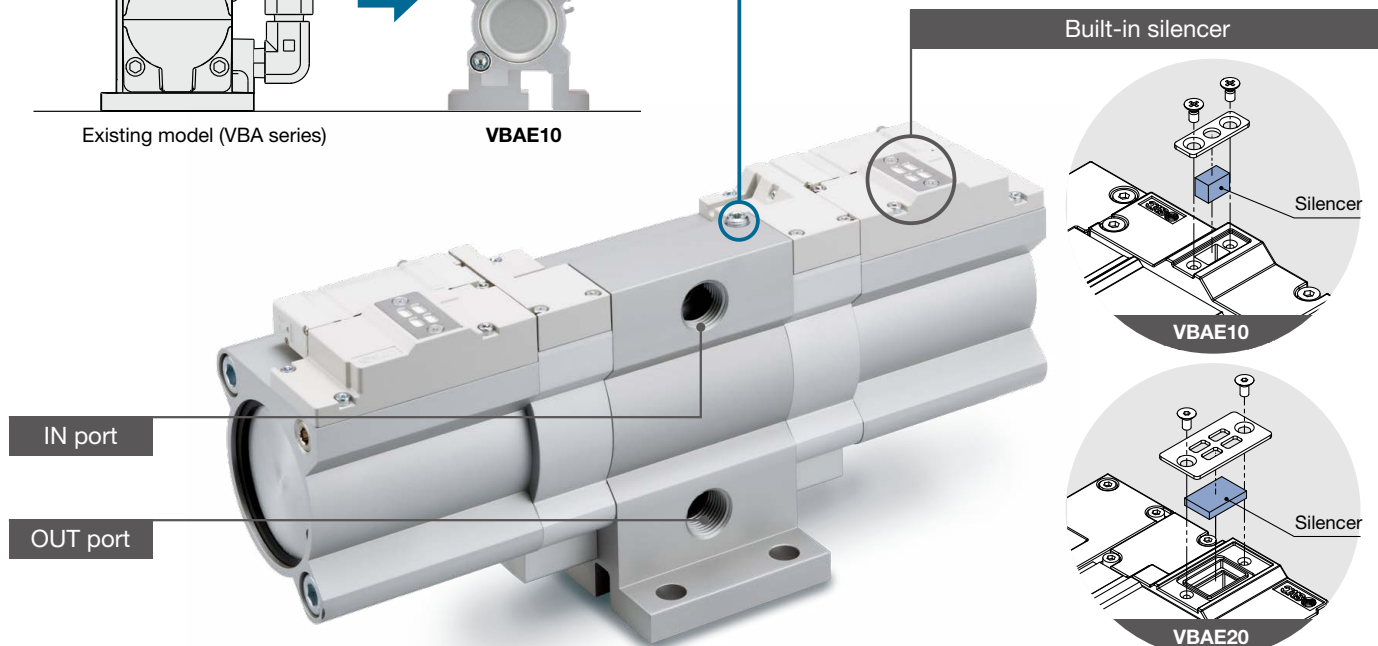

A regulator can be mounted. (Details p. 5)

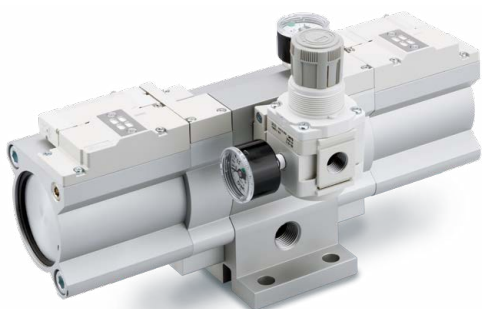

An auto switch can be mounted.

- Operating cycle count is possible using an auto switch.

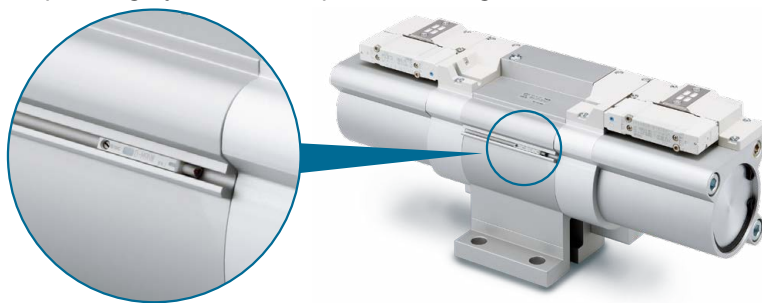

Compatible with vertical and horizontal installation

- Improved mounting flexibility

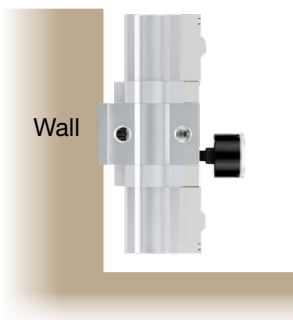

Mounting interchangeability with the existing model (VBA series)

- Can be mounted to an air tank. (VBAT series)



Air tank details

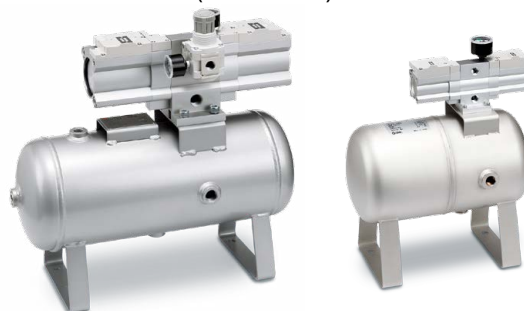

Proposal for reducing pressure

Reduced pressure

Local pressure increase only where high pressure is required, thereby reducing overall factory pressure

Line pressure **0.4 MPa**

Power supply not required

Local pressure increase
0.6 MPa

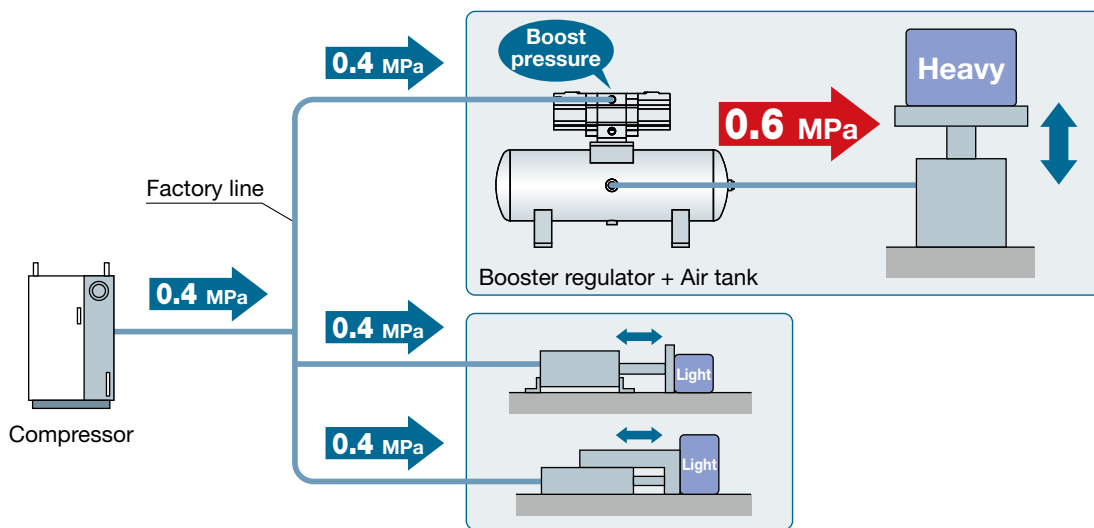
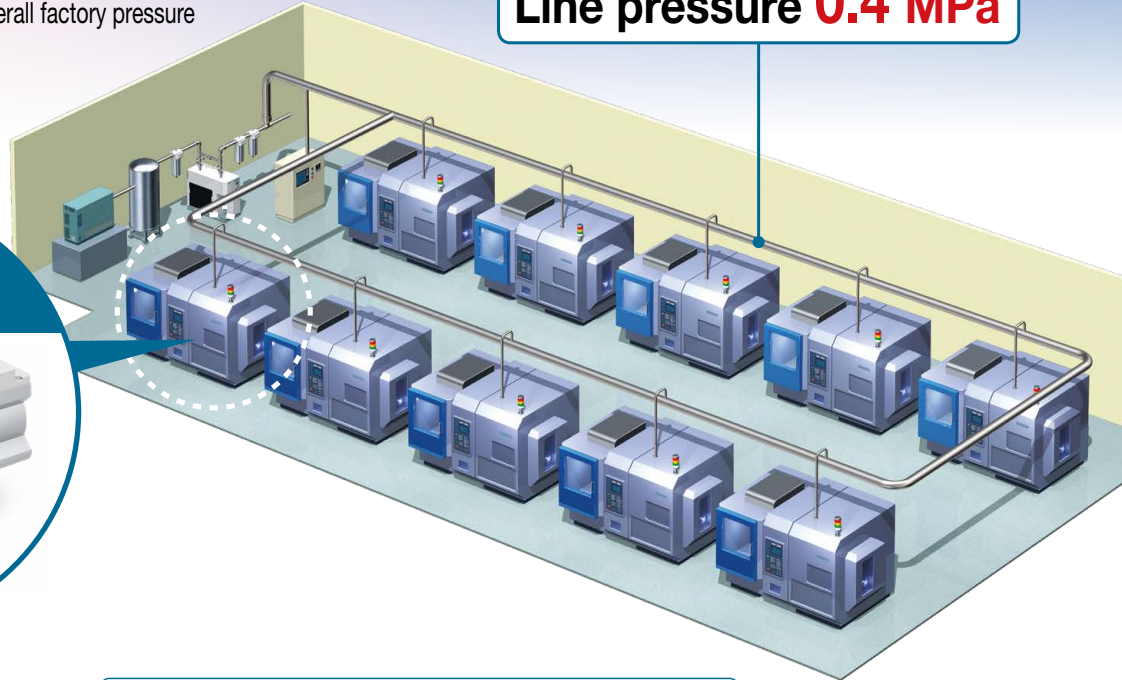
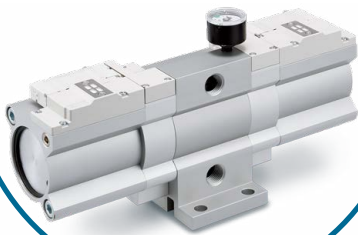

Energy Saving, Exhaust-Recovery Booster Regulator

Series	Model	Nominal size	Body size	Pressure increase ratio	Max. flow rate [L/min(ANR)]	Outlet pressure range [MPa]	Pressure adjustment mechanism (Operating method)	Installation
	VBAE	10	1/4	1.7 times (Fixed)	230	0.3 to 1.2	Fixed type (Without pressure adjustment mechanism)	Horizontal Vertical
		20	3/8		1000	0.3 to 1.2		

CONTENTS

Energy Saving, Exhaust-Recovery Booster Regulator *VBAE Series*

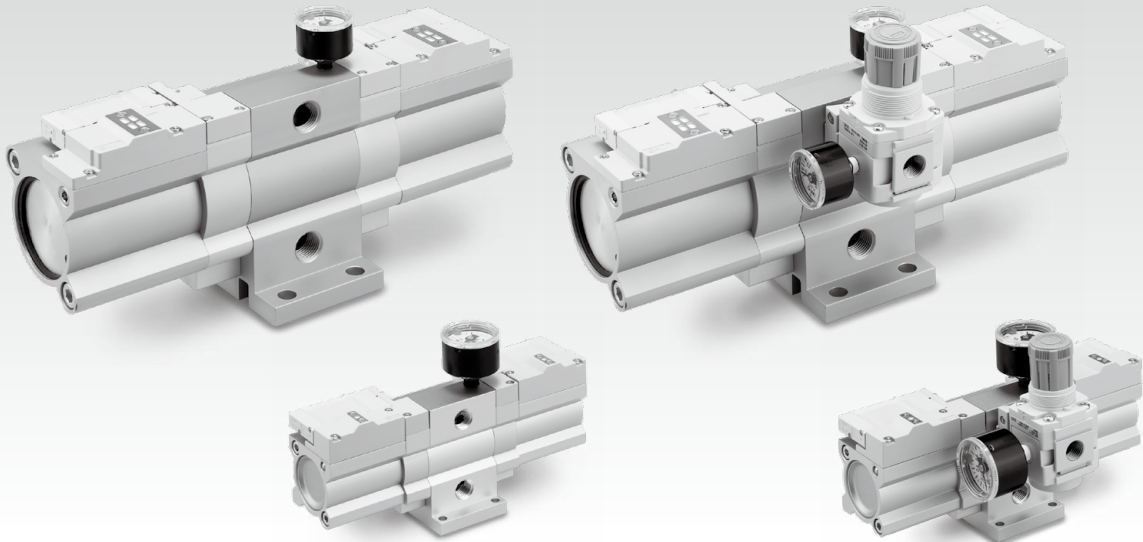

How to Order.....	p. 4
Standard Specifications	p. 4
Options / Part Nos.	p. 5
Solid State Auto Switches (To Be Ordered Separately)	p. 5
Characteristics	p. 6
Sizing	p. 7
Working Principle	p. 9
Circuit Example	p. 9
Construction / Replacement Parts	p. 10
Dimensions	p. 11
Specific Product Precautions	p. 15

Energy Saving, Exhaust-Recovery Booster Regulator

VBAE Series

Size 10, 20

RoHS

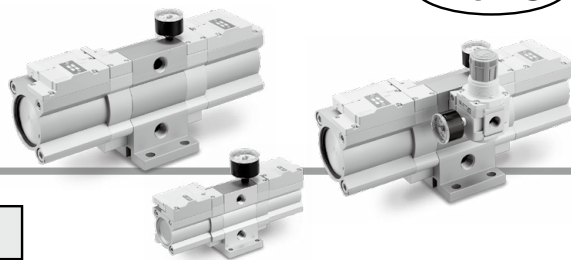

How to Order

VBAE **20** - **04** -

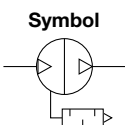

Body size

Symbol	Body size
10	1/4
20	3/8

Thread type*1

Symbol	Thread type
Nil	Rc
F	G
N	NPT

Port size

Symbol	Port size	Applicable model
02	1/4	VBAE10
04	1/2	VBAE20

Semi-standard

Symbol	Semi-standard
Nil	Standard product
Z*4	Pressure unit on the product name label: psi Pressure unit on the pressure gauge : MPa and psi

Option*5

	Symbol	Description	Body size	
			10	20
a	Bolt	Nil	●	●
		B	—*2	●*3
b	Regulator	Nil	●	●
		D	●	●
		E	●	●
c	Pressure gauge	Nil	●	●
		G	●	●

* Select one item for "a," "b," and "c."

- *1 Thread types apply to the IN and OUT ports. The gauge ports are Rc thread type regardless of the thread type indication.
- *2 When mounting a booster regulator to an air tank, use the included tank mounting bolt.
- *3 Be sure to use the dedicated air tank mounting bolt (option "B", M10 x 1.5 x 25: 4 pcs) when mounting to an air tank. (The length varies from that of the included tank mounting bolt.)
- *4 For the pipe thread type: NPT
This product is for overseas use only according to the New Measurement Act. (The SI unit type is provided for use in Japan.)
- *5 Options are shipped together with the product.

Standard Specifications

Model	VBAE10	VBAE20
Fluid	Compressed air	
Pressure increase ratio	1.7 times (Fixed)	
Max. flow rate*1 [L/min (ANR)]	230	1000
Outlet pressure range [MPa]	0.3 to 1.2	
Inlet pressure range [MPa]	0.2 to 0.7	
Proof pressure [MPa]	1.8	
Port size (IN, OUT) [Rc]	1/4	1/2
OUT side gauge port [Rc]	1/8	
Tank connection port (with plug)*2	1/4	1/2
Ambient and fluid temperatures [°C]	2 to 50 (No freezing)	
Installation	Horizontal, Vertical	
Lubrication	Grease (Non-lube)	
Weight [kg]	1.2	5.0

- *1 Flow rate at IN = OUT = 0.5 MPa. The pressure varies depending on the operating conditions. Refer to "Flow Rate Characteristics" on page 6.
- *2 The tank connection port cannot be used for applications other than the connection with VBAT.

Air Tank Compatibility Chart

Booster regulator	VBAE10	VBAE20
Air tank		
VBAT05A(1)	●	—
VBAT05S(1)	●	—
VBAT10A(1)	●	●
VBAT10S(1)	●	●
VBAT20A(1)	—	●
VBAT20S(1)	—	●
VBAT38A(1)	—	●
VBAT38S(1)	—	●

- * Be sure to confirm the operating pressure range of the air tank.
For details on air tanks, refer to the **Web Catalog**.



Air tank details

VBAE Series

Options / Part Nos.

Model	① Regulator	② Modular adapter	③ Spacer	④ OUT side pressure gauge
VBAE10-02□	AR20-02G-D	E210-U02	Y200-D	G36-15-01
VBAE10-F02□	AR20-F02G-D			
VBAE10-N02□ (Without "-Z")	AR20-N02G-D			
VBAE10-N02□-Z	AR20-N02G-Z-D			
VBAE20-04□	AR40-04G-D	E410-U04	Y400-D	G36-15-01
VBAE20-F04□	AR40-F04G-D			
VBAE20-N04□ (Without "-Z")	AR40-N04G-D			
VBAE20-04□-Z	AR40-N04G-Z-D			

Regulator Specifications

Model	AR20-□02G-D	AR40-□04G-D
Regulator IN port size (Rc, NPT, G)	1/4	1/2
Regulator pressure gauge*1	1/8	

*1 The regulator pressure gauge is shipped together with the product.

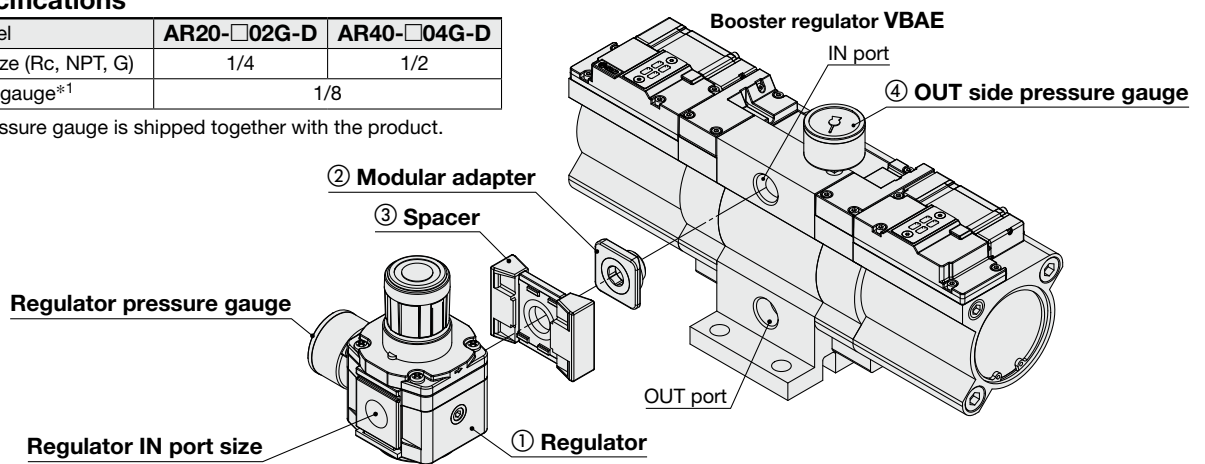

Mounting a Regulator

1. The regulator knob can be fixed in any position within 360° as long as it does not interfere with the OUT port. The regulator pressure gauge that is shipped together with the product needs to be mounted by the customer. Note that it can be mounted with the knob facing either left or right.

Mounting Example

Upward-facing regulator knob

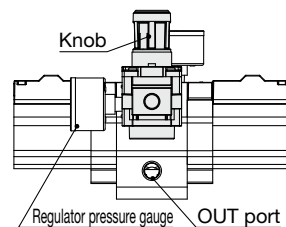

Side-facing regulator knob

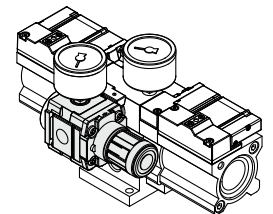
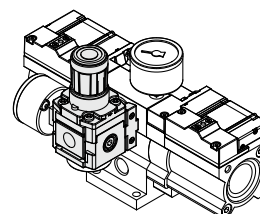
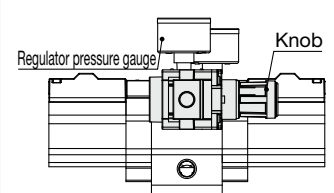

① Regulator details



② Modular adapter/
③ Spacer details



④ OUT side pressure gauge details

Solid State Auto Switches (To Be Ordered Separately) / Refer to the Web Catalog for further information on auto switches.

Auto switch model	Electrical entry	Indicator light	Wiring (Output)	Load voltage		Applicable load	
				DC		IC circuit	Relay, PLC
D-M9N	Grommet	Yes	3-wire (NPN)	24 V	5 V,		
D-M9P			3-wire (PNP)		12 V		
D-M9B			2-wire		12 V		

* Lead wire length symbols: 0.5 m Nil (Example) D-M9N
 1 m M (Example) D-M9NM
 3 m L (Example) D-M9NL
 5 m Z (Example) D-M9NZ

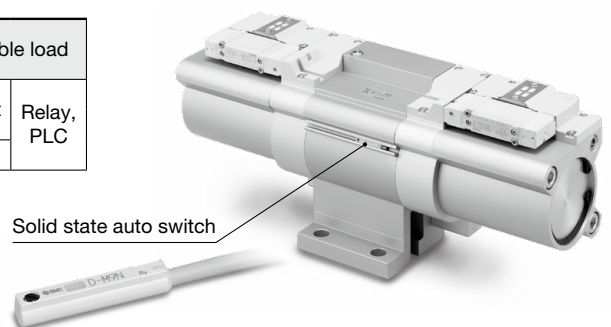

Solid line: Operating range

Operate so that the flow rate follows the solid line even when the outlet side air has been consumed.

Ex.) For the VBAE10: When the inlet pressure is 0.5 MPa and the set pressure is 0.8 MPa, operate at an outlet air flow rate of 100 L/min (ANR) or less.

P₁: Inlet pressure

P₂: Outlet pressure

Characteristics

VBAE10

Flow Rate Characteristics

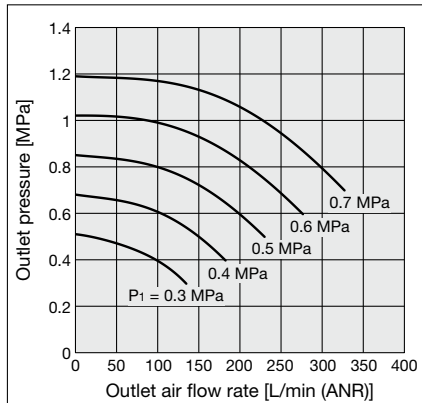

Charge Characteristics

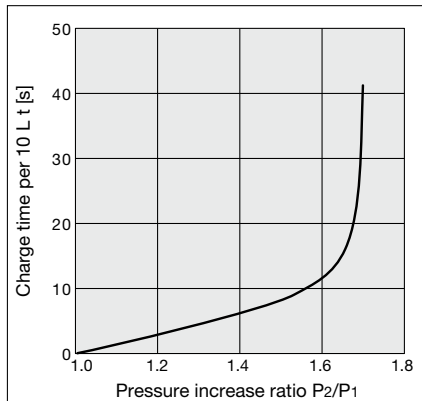

VBAE10

- The time required to charge pressure in the tank from 0.6 MPa to 0.8 MPa at 0.5 MPa supply pressure:

$$\frac{P_2}{P_1} = \frac{0.6}{0.5} = 1.2 \quad \frac{P_2}{P_1} = \frac{0.8}{0.5} = 1.6$$

With the pressure increase ratio from 1.2 to 1.6, the charge time of 12 - 4 = 8 s (t) is given by the graph. Then, the charge time (T) for a 10 L tank:

$$T = t \times \frac{V}{10} = 8 \times \frac{10}{10} = 8 \text{ (s)}$$

VBAE20

Flow Rate Characteristics

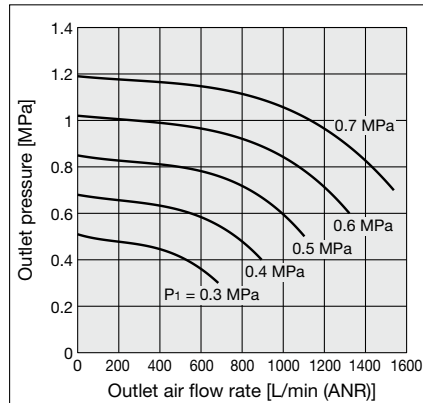

Charge Characteristics

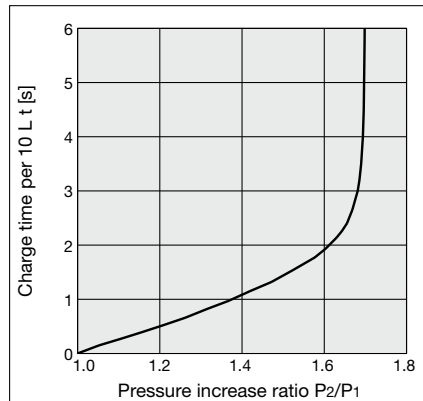

VBAE20

- The time required to charge pressure in the tank from 0.6 MPa to 0.8 MPa at 0.5 MPa supply pressure:

$$\frac{P_2}{P_1} = \frac{0.6}{0.5} = 1.2 \quad \frac{P_2}{P_1} = \frac{0.8}{0.5} = 1.6$$

With the pressure increase ratio from 1.2 to 1.6, the charge time of 1.9 - 0.5 = 1.4 s (t) is given by the graph. Then, the charge time (T) for a 100 L tank:

$$T = t \times \frac{V}{10} = 1.4 \times \frac{100}{10} = 14 \text{ (s)}$$

Pulsation/Pulsation is decreased with a tank.

If the outlet capacity is undersized, pulsation may occur.

VBAT05A

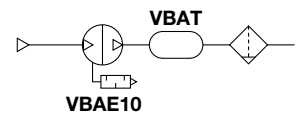
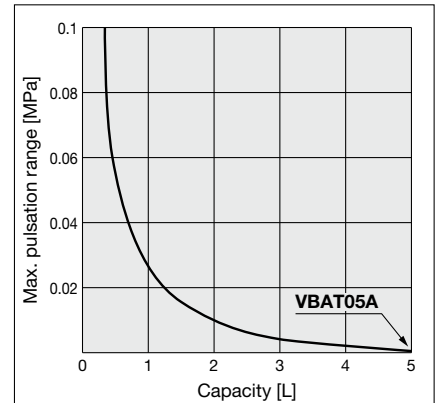

VBAT10A, VBAT20A, VBAT38A

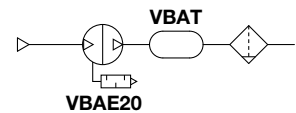
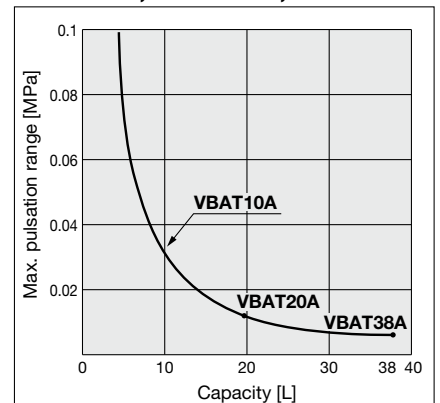

Conditions: Inlet pressure: 0.5 MPa
Outlet pressure: 0.85 MPa
Flow rate: Between 0 and max. flow rate

- Performance of air tank
 - Alleviates the pulsation generated on the outlet side.
 - When air consumption exceeds air supply during intermittent operation, required air will be accumulated in the tank for use. This does not apply for continuous operation.

Sizing (Please use the Booster Regulator Model Selection Software on the SMC website:
<https://mssc.smcworld.com/brmss/>)

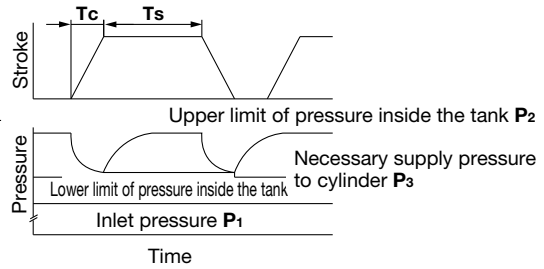
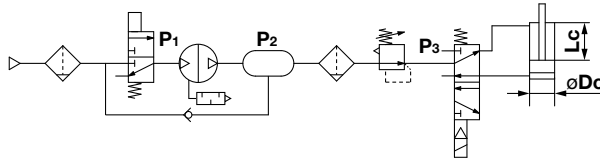

START

Provide requisite conditions for selection.

Necessary conditions:

- Dc** [mm]: Cylinder bore size
- Lc** [mm]: Cylinder stroke
- N** [pc.]: Number of cylinders
- Tc** [s]: Cylinder operating time
- Dr** [mm]: Piping bore (Valve-Cylinder)
- Lr** [mm]: Piping length (Valve-Cylinder)
- C** [cpm]: Operating frequency
- P1** [MPa]: Booster regulator inlet pressure
- P3** [MPa]: Necessary supply pressure for cylinder
- P2** [MPa]: Booster regulator outlet pressure (Set pressure)

* **P3** is the necessary supply pressure to a cylinder, and set the pressure below the lower limit of pressure inside the tank with a regulator. Adjust the pressure taking the max. operating pressure of equipment in use into consideration.
 * **P2** is the output pressure of the booster regulator, which is also the upper limit of charge pressure to the tank.

Other conditions:

- QAVE** [L/min]: Average air flow rate
- QMAX** [L/min]: Max. instantaneous air flow rate
- K**: Cylinder double-acting: 2, single-acting: 1
- T1** [s]: Time to charge (Time to charge to **P3**)
- T2** [s]: Time to charge (Time to charge to **P2**)
- T** [s]: Time to charge (Time to charge from **P3** to **P2**)

Obtain the capacity (V).

Obtain the piping volume from the valve to the actuator and the volume of the actuator to obtain the air flow rate from the outlet side of the booster regulator.

Cylinder volume

$$V_{CYL} [L] = \frac{\pi \times Dc^2 \times Lc}{4 \times 10^6} \times \frac{P3 + 0.101}{0.101} \times N$$

Piping capacity

$$V_{TUBE} [L] = \frac{\pi \times Dr^2 \times Lr}{4 \times 10^6} \times \frac{P3}{0.101} \times N$$

Calculate air flow rate (Q).

Obtain the average air flow rate **QAVE** to select the size of the booster regulator.

Average air flow rate

$$Q_{AVE} [L/min (ANR)] = (V_{CYL} + V_{TUBE}) \times 2 \times C \text{ (Reciprocation)}$$

Obtain the max. instantaneous air flow rate **QMAX** to check the necessity of an air tank.

Max. instantaneous air flow rate

$$Q_{MAX} [L/min (ANR)] = \frac{(V_{CYL} + V_{TUBE})}{Tc} \times 60$$

Select the booster regulator and check the necessity of an air tank.

Select the booster regulator from the average air flow rate **QAVE** and check the necessity of an air tank from the max. instantaneous air flow rate **QMAX**.

It can be used when the outlet air flow rate of the intersecting point between the booster regulator inlet pressure (**P1**) and necessary supply pressure to cylinder (**P3**) on the catalog flow characteristic table (p. 6) is equal to the average air flow rate **QAVE** or higher.

An air tank is required when the outlet air flow rate is less than the max. instantaneous air flow rate **QMAX**.

An air tank is not required when the outlet air flow rate is at the max. instantaneous air flow rate **QMAX** or higher.

Selection example	
Dc [mm]: 50	Lr [mm]: 500
Lc [mm]: 100	C [cpm]: 6
N [pc.]: 1	P1 [MPa]: 0.5
Tc [s]: 0.5	P3 [MPa]: 0.7
Dr [mm]: 4	P2 [MPa]: 0.85

$$V_{CYL} [L] = \frac{\pi \times 50^2 \times 100}{4 \times 10^6} \times \frac{0.7 + 0.101}{0.101} \times 1 = 1.55 [L]$$

$$V_{TUBE} [L] = \frac{\pi \times 4^2 \times 500}{4 \times 10^6} \times \frac{0.7}{0.101} \times 1 = 0.04 [L]$$

$$Q_{AVE} [L/min (ANR)] = (1.55 + 0.04) \times 2 \times 6 = 19 [L/min (ANR)]$$

$$Q_{MAX} [L/min (ANR)] = \frac{(1.55 + 0.04)}{0.5} \times 60 = 191 [L/min (ANR)]$$

⚠ Caution

- Since the booster regulator is a compressor powered by the air, it consumes the air. The air consumption is approx. 0.72 times larger than the outlet side volume. Therefore, the booster regulator requires a supply capacity of the inlet side volume that is approx. 1.72 times larger than the outlet side volume.

Selection example

P_1 : 0.5 [MPa], P_2 : 0.7 [MPa] → **Outlet air flow rate**
VBAE10: 150 [L/min]
VBAE20: 800 [L/min]

Average air flow rate Q_{AVE} : 19 [L/min]
 Max. instantaneous air flow rate Q_{MAX} : 191 [L/min]

VBAE10

Flow Rate Characteristics

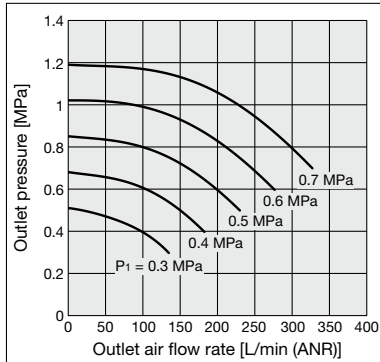

VBAE20

Flow Rate Characteristics

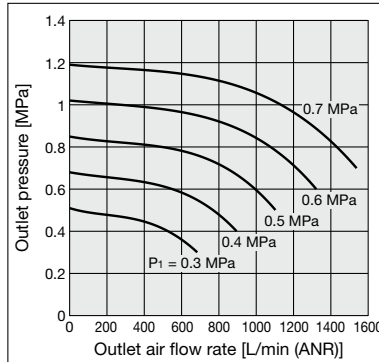

Results

The outlet air flow rate of **VBAE10** is equal to the average air flow rate Q_{AVE} or higher but it is less than the max. instantaneous air flow rate Q_{MAX} . Therefore, it can be used but an air tank is required.

The outlet air flow rate of **VBAE20** is equal to the average air flow rate Q_{AVE} or higher and the max. instantaneous air flow rate Q_{MAX} or higher. Therefore, it can be used without an air tank.

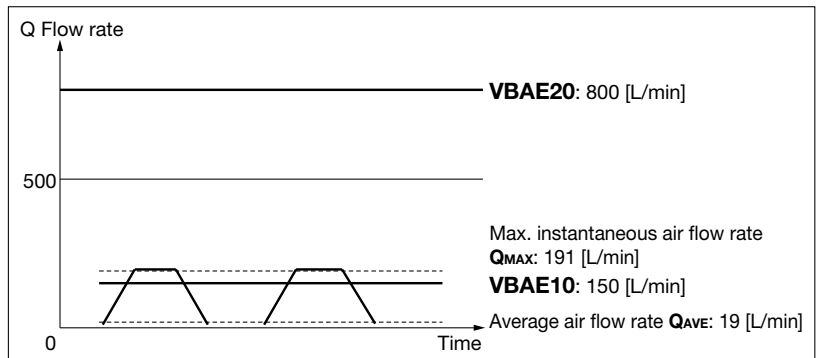

Booster regulator selection and air tank necessity confirmation results

Obtain the air tank capacity.

Obtain the air tank capacity.

$$V [L] = \frac{Q_{MAX}}{(P_2 - P_3) \times 9.9} \times \frac{T_c}{60} \times K$$

Check the air tank charge characteristics.

Obtain the time T from the catalog charge characteristics table (p. 6) and check that it satisfies the operating frequency.

$$T = \left(\frac{V}{10}\right) \times (T_2 - T_1) \leq \frac{60}{C}$$

Application example

$$T = \left(\frac{2.1}{10}\right) \times (40 - 6) = 7.1 \leq \frac{60}{6}$$

A tank smaller than the calculation results may satisfy the requirement since this size selection calculation provides calculation which is on the safe side. This does not consider air flowing from the booster regulator. Please use the booster regulator model selection software on the SMC website.

Application example

Required air tank volume for **VBAE10**

$$V [L] = \frac{191}{(0.85 - 0.7) \times 9.9} \times \frac{0.5}{60} \times 2 = 2.1 [L]$$

* Air tank of 2.1 L or more is required.

VBAE10

Charge Characteristics

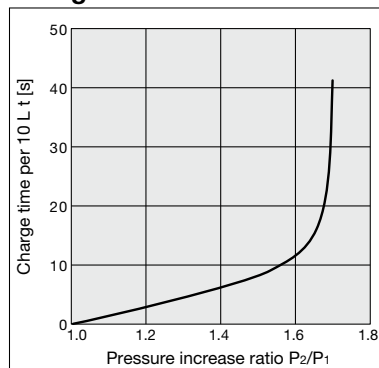

END

When running continuously for longer periods of time, confirm the life expectancy. When the life expectancy is shorter than required, select a larger sized booster regulator.

VBAE Series

Working Principle

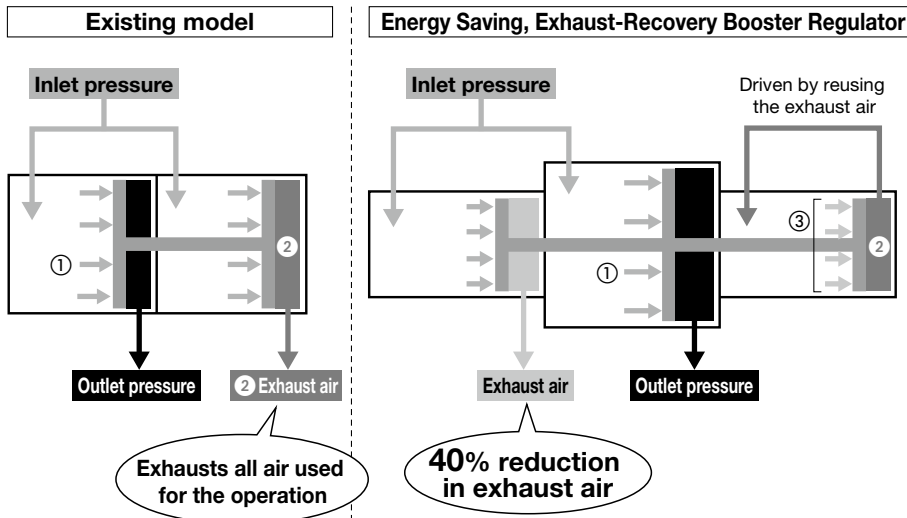

The existing model has two pistons and four chambers.

The inlet pressure enters two chambers and pushes the pistons in the direction of the arrows ① and outputs compressed air as outlet pressure. Simultaneously, the air in ② is exhausted when finished pushing the piston.

The energy saving, exhaust-recovery booster regulator has three pistons and six chambers.

The inlet pressure enters two chambers and pushes the pistons in the direction of the arrows ①. Simultaneously, the exhaust air ② that was used to push the pistons in the previous process is introduced into the next chamber, where it pushes the next piston in the direction of the arrows ③. The reused air is then exhausted in the next process.

The existing model exhausted all air that pushes the pistons. However, the energy saving, exhaust-recovery booster regulator recycles air to operate the pistons, which reduces 40% of the exhaust air volume.

Circuit Example

- When only some of the machines in the factory require high-pressure air, booster regulators can be installed for only the machines that require it. This allows the overall system to use low-pressure air while accommodating machines requiring high-pressure air.

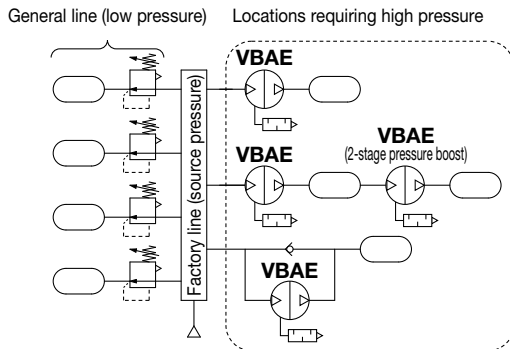

* When using 2 booster regulators for 2-stage pressure boost, be sure to supply sufficient flow to each booster regulator in order to stabilize the booster regulator inlet pressure. Refer to "Selection 1" on page 15 for the inlet side supply amount.

- When charging a tank or the like from a source at atmospheric pressure, a circuit with a check valve can be used to reduce the charge time by allowing air to pass through the check valve up to the inlet pressure.

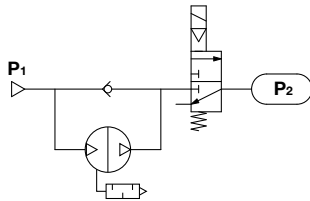

Initially, inlet pressure (P_1) passes through the check valve, fills P_2 , and results in $P_1 = P_2$.

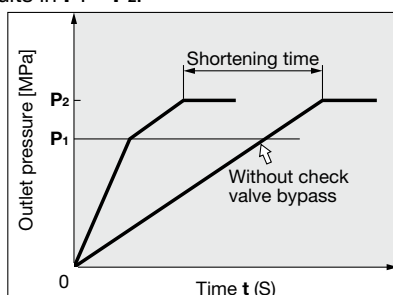

- When the actuator output is insufficient, but space limitations prohibit switching to a larger cylinder diameter, a booster regulator can be used to increase the pressure. This makes it possible to boost the output without replacing the actuator.
- When a certain level of output is required, but the cylinder size must be kept small so that the driver remains compact, a booster regulator can be used to attain the required amount of output.

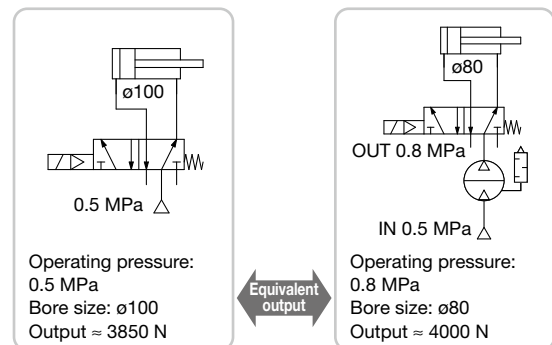

- When only one side of the cylinder is used for work, booster regulators can be installed only on the lines that require them to reduce the overall air consumption volume.

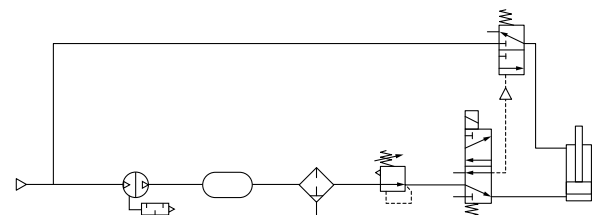

Construction / Replacement Parts

VBAE10, VBAE20

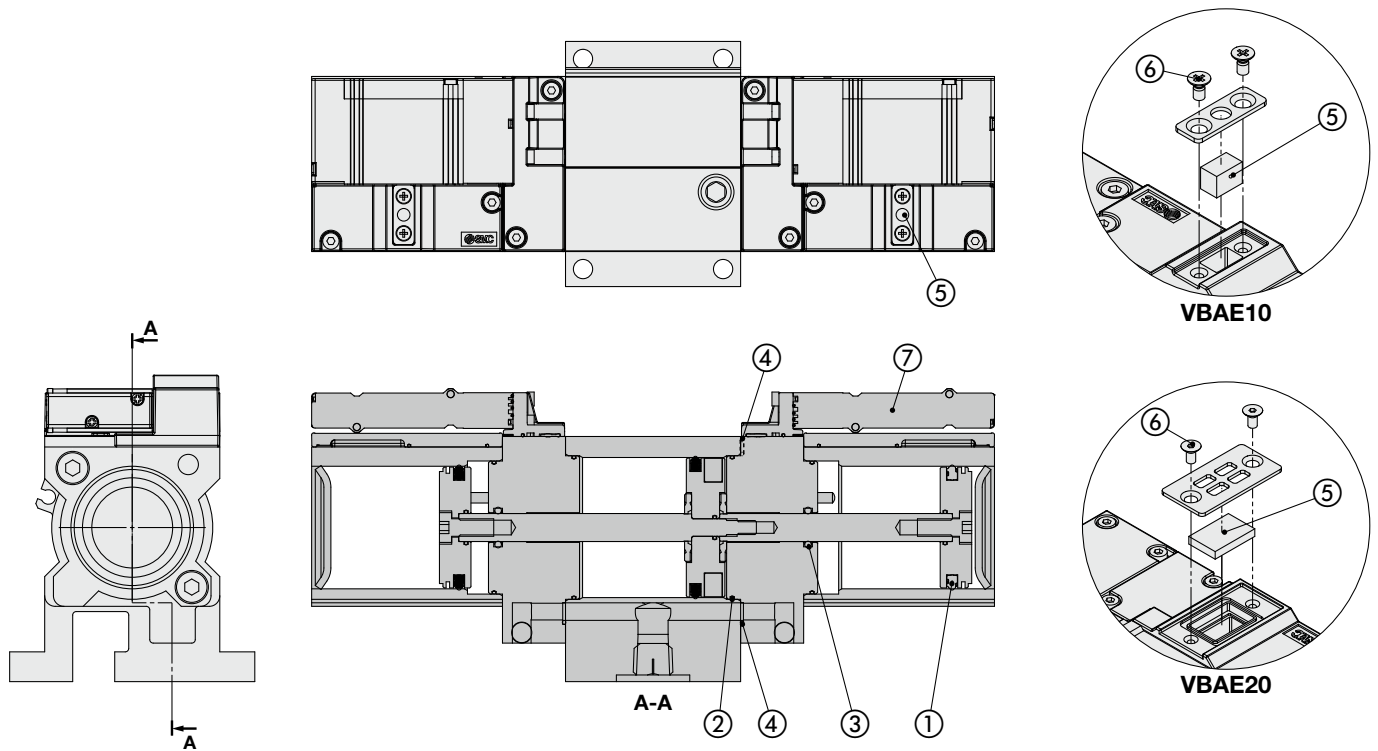

Replacement Parts / Kit Nos.

Place an order with the following applicable kit number.

Model	VBAE10	VBAE20
Kit no.	KT-VBAE10-1	KT-VBAE20-1

- * The grease pack has 10 g of grease.
- * Make sure to refer to the procedure for maintenance.
- * For details on the replacement parts kit, refer to the procedure for maintenance.

The kit includes the following parts and a grease pack.

No.	Description	Model	
		VBAE10	VBAE20
		Quantity	
1	Piston seal	1 large, 2 small	
2	Tube gasket	2 large, 2 small	
3	Rod seal	2	
4	O-ring	11	
5	Silencer	2	
6	Flat head screw	4	
7	Switching valve	2	
—	Check valve assembly	4	
—	Pilot valve assembly	2	
—	Gasket	6	
—	Pilot silencer	—	4
—	Grease pack	1	—



Operation Manual/
Procedure for maintenance

VBAE Series

Dimensions

VBAE10

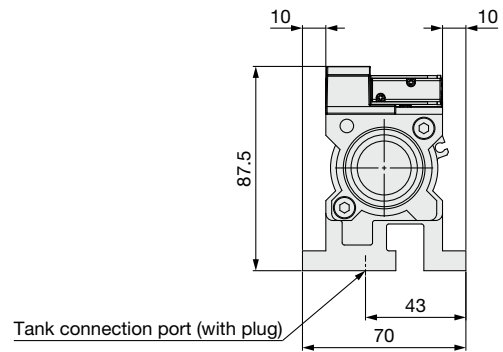
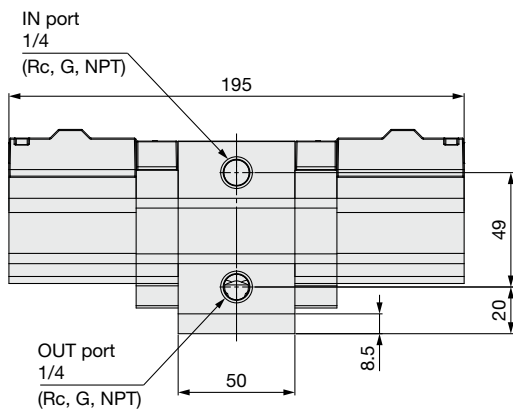
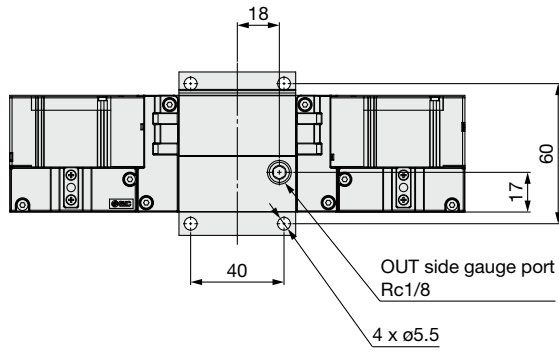
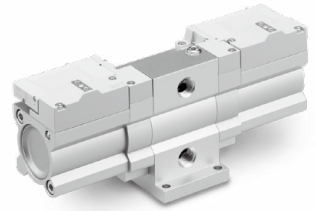

When equipped with a regulator/pressure gauge

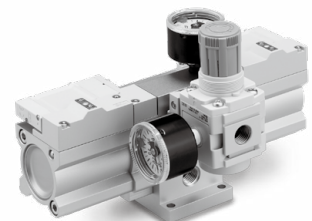
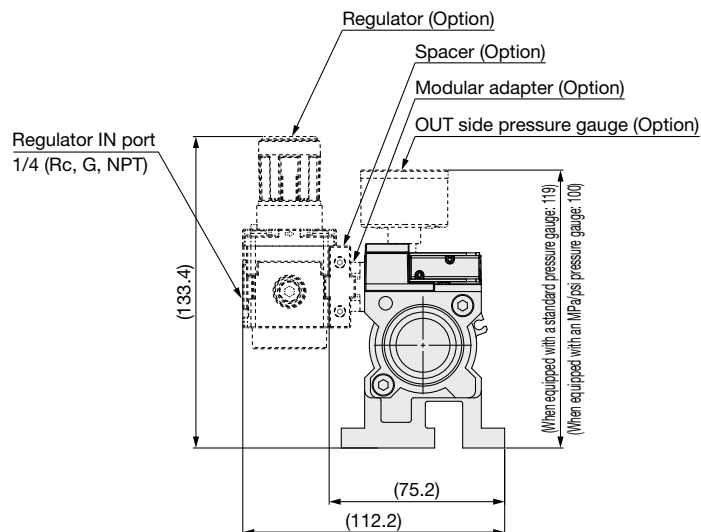

Dimensions

VBAE20

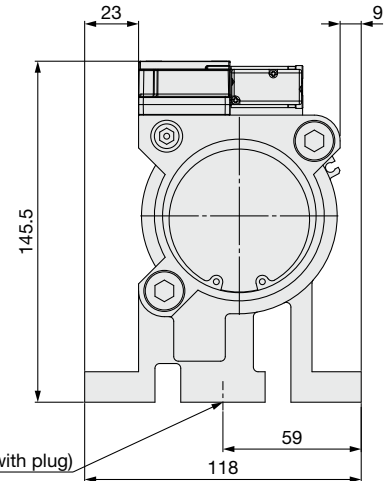
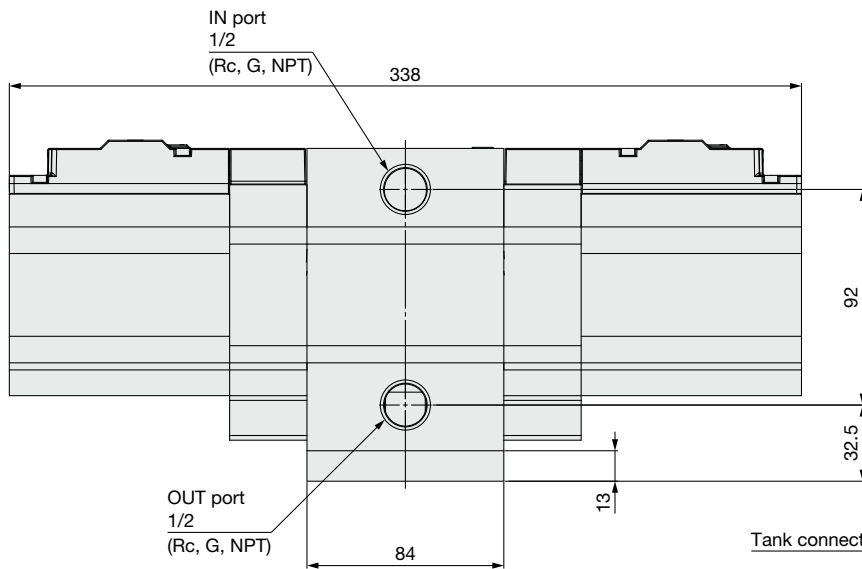
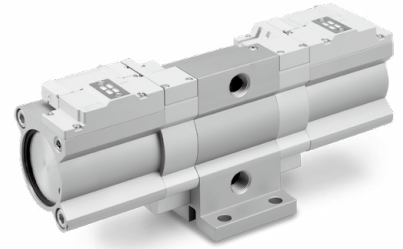
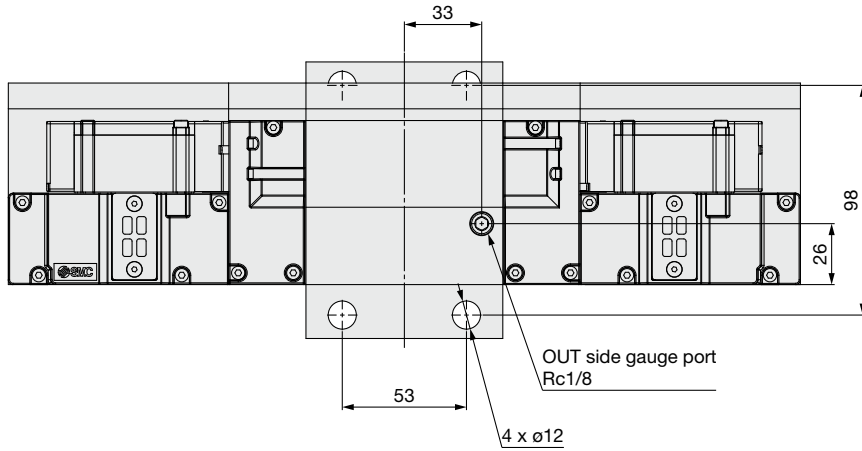

When equipped with a regulator/pressure gauge

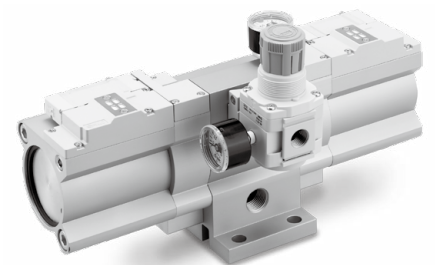
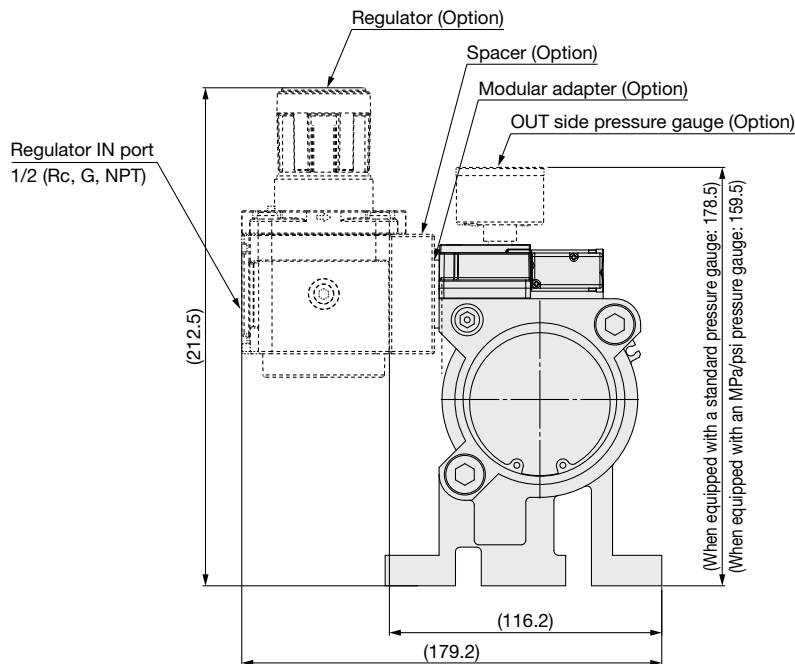

VBAE Series

* The length may be longer than the specification if the plugs mounted on the tank are not fit to the end.
 * Refer to the VBAT catalog for details on tank option mounting positions, etc.



Air tank details

Dimensions (When mounted on an air tank)

For 5L

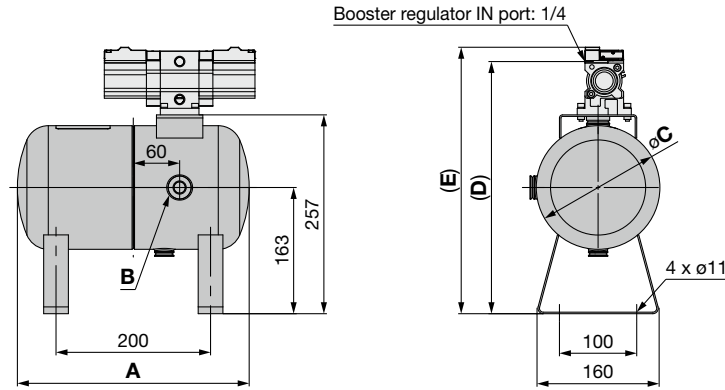

Booster regulator model	Standard products (For Japanese market)						CE/UKCA marking-conformity products			ASME certified products/CRN approved products (For the U.S. and Canada)			Chinese pressure vessel regulations compliant products						Same for all tanks	
	VBAT05A1			VBAT05S1			VBAT05A-Q			VBAT05AN1-E-X105 VBAT05A1-E-X105 VBAT05SN1-E-X105 VBAT05S1-E-X105			VBAT05A1-U-X104			VBAT05S1-U-X104				
	A	B	C	A	B	C	A	B	C	A	B	C	A	B	C	A	B	C		
VBAE10	349	Rc3/8	156	300	Rc3/8	160	360	Rc3/8 G3/8	156	374	Rc3/8 NPT3/8	150 (148)	374	Rc3/8	150	374	Rc3/8	149	326	344.5

(): Dimension of the VBAT05S(N)1-E-X105

For 10L

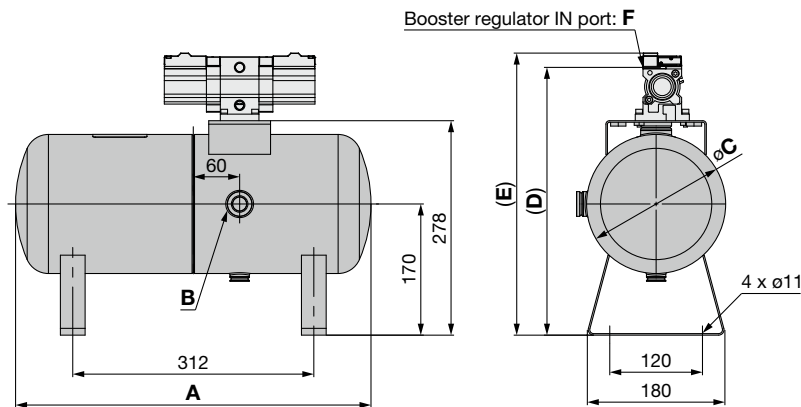

Booster regulator model	Standard products (For Japanese Market)						CE/UKCA marking-conformity products			ASME certified products/CRN approved products (For the U.S. and Canada)			Chinese pressure vessel regulations compliant products						Same for all tanks		
	VBAT10A1			VBAT10S1			VBAT10A-Q			VBAT10AN1-E-X105 VBAT10A1-E-X105 VBAT10SN1-E-X105 VBAT10S1-E-X105			VBAT10A1-U-X104			VBAT10S1-U-X104					
	A	B	C	A	B	C	A	B	C	A	B	C	A	B	C	A	B	C			
VBAE10	471	Rc1/2	180	460	Rc1/2	180	482	Rc1/2 G1/2	180	522	Rc1/2 NPT1/2	170	522	Rc1/2	170	522	Rc1/2	170	347	365.5	1/4
VBAE20																			402.5	423.5	1/2

Energy Saving, Exhaust-Recovery Booster Regulator **VBAE Series**

* The length may be longer than the specification if the plugs mounted on the tank are not fit to the end.
 * Refer to the VBAT catalog for details on tank option mounting positions, etc.



Air tank details

Dimensions (When mounted on an air tank)

For 20L

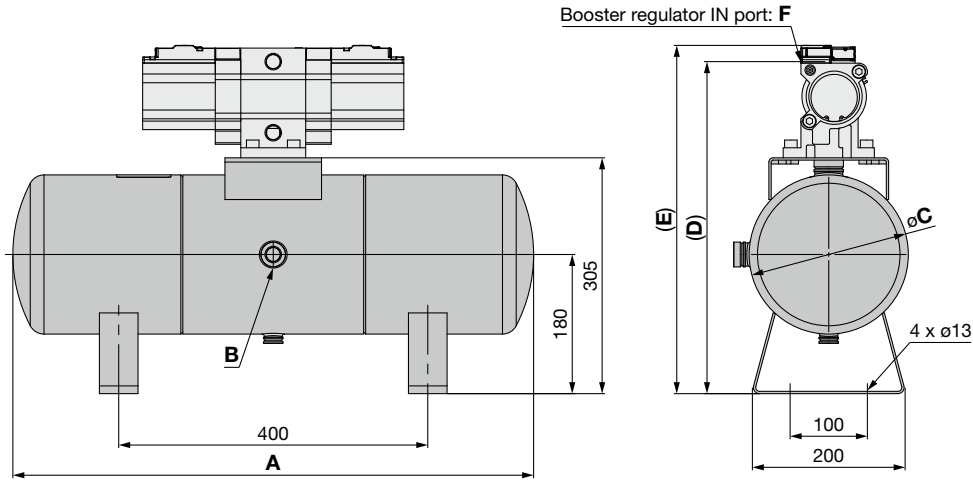

Booster regulator model	Standard products (For Japanese market)						CE/UKCA marking-conformity products			ASME certified products/CRN approved products (For the U.S. and Canada)			Chinese pressure vessel regulations compliant products						Same for all tanks		
	VBAT20A1			VBAT20S1			VBAT20A-Q			VBAT20AN1-E□-X105 VBAT20A1-E□-X105 VBAT20SN1-E□-X105 VBAT20S1-E□-X105			VBAT20A1-T-X104			VBAT20S1-T-X104					
	A	B	C	A	B	C	A	B	C	A	B	C	A	B	C	A	B	C			
VBAE20	685	Rc1/2	206	674	Rc1/2	206	696	Rc1/2 G1/2	206	700	Rc1/2 NPT1/2	216	700	Rc1/2	216	700	Rc1/2	216	429.5	450.5	1/2

For 38L

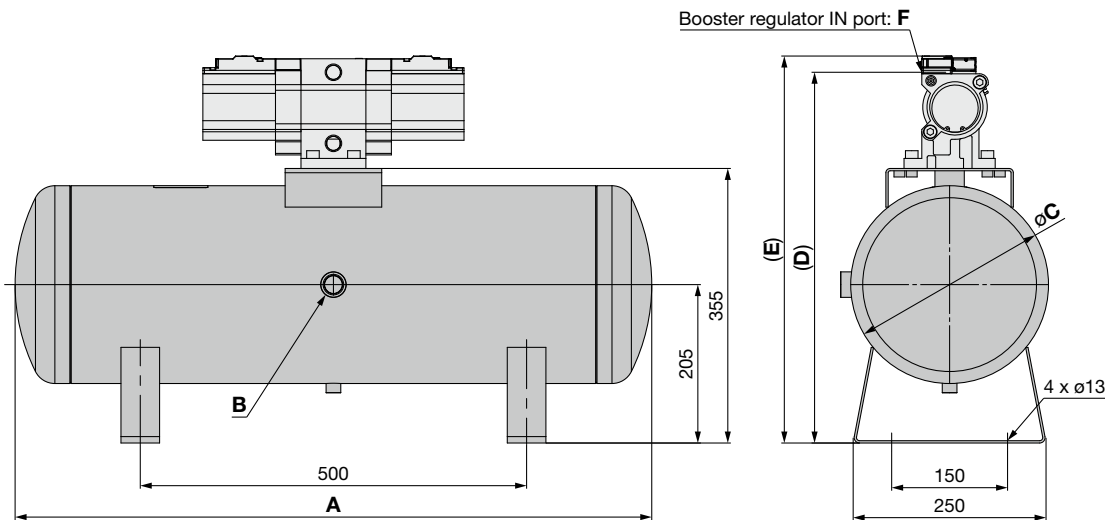

Booster regulator model	Standard products (For Japanese market)						CE/UKCA marking-conformity products			ASME certified products/CRN approved products (For the U.S. and Canada)			Chinese pressure vessel regulations compliant products						Same for all tanks		
	VBAT38A1			VBAT38S1			VBAT38A-Q			VBAT38AN1-E□-X105 VBAT38A1-E□-X105 VBAT38SN1-E□-X105 VBAT38S1-E□-X105			VBAT38A1-T-X104			VBAT38S1-T-X104					
	A	B	C	A	B	C	A	B	C	A	B	C	A	B	C	A	B	C			
VBAE20	835	Rc3/4	256	824	Rc3/4	256	846	Rc3/4 G3/4	256	873	Rc3/4 NPT3/4	250	873	Rc3/4	252	873	Rc3/4	250	479.5	500.5	1/2



Specific Product Precautions 1

Be sure to read this before handling the products. Refer to the back cover for safety instructions. For F.R.L. units and auto switch precautions, refer to the "Handling Precautions for SMC Products" and the "Operation Manual" on the SMC website: <https://www.smcworld.com>

Design

⚠ Warning

1. Warning concerning abnormal outlet pressure

- If there is a likelihood of causing an outlet pressure drop due to unforeseen circumstances such as equipment malfunction, thus leading to a major problem, take safety measures on the system side.
- Because the outlet pressure could exceed its set range if there is a large fluctuation in the inlet pressure, leading to unexpected accidents, take safety measures against abnormal pressures.
- Use within the outlet pressure range.

2. Residual pressure measures

- Connect a 3-port valve to the OUT side of the booster regulator if the residual pressure must be released quickly from the outlet pressure side for maintenance, etc. (Refer to the diagram below.) The residual outlet pressure side cannot be released even if the 3-port valve is connected to the IN side because the check valve in the booster regulator will activate.

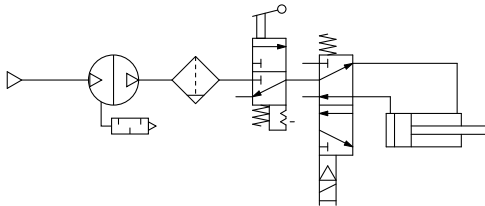

- Discharge the inlet charge pressure after the operation. It stops the operation of the booster regulator and prevents unnecessary air consumption.

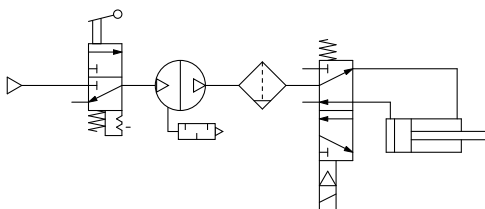

⚠ Caution

1. System configuration

- **Select an inlet piping size with a sufficient margin.**
Since the booster regulator is a compressor powered by the air, it consumes the air. The air consumption is approx. 0.72 times larger than the outlet side volume. Therefore, the booster regulator requires a supply capacity of the inlet side volume that is approx. 1.72 times larger than the outlet side volume.
- Ensure sufficient air charge capability of the min. operating pressure (0.2 MPa) or more. The switching valve may not operate when the internal operating pressure is equal to the min. operating pressure or less.
- The booster regulator has a sliding part inside, and it generates dust. Also, install an air purification device such as an air filter or a mist separator on the outlet side as necessary.
- Connect a lubricator to the outlet side, because the accumulated oil in the booster regulator may result in a malfunction.
- Pay attention to the max. operating pressure range and operate within these specifications of peripheral equipment.

2. Quality of air source

- **Install an air filter.**
Install an air filter on the inlet side of the booster regulator. Select an air filter with a filtration degree of 5 μm or finer.
- **Take measures to ensure air quality, such as by installing an aftercooler, air dryer, or water separator.**
Compressed air that contains a large amount of drainage can cause the malfunction of pneumatic equipment, such as valves. Therefore, take appropriate measures to ensure air quality, such as by providing an aftercooler, air dryer, or water separator.
- **If an excessive amount of carbon powder is present, install a mist separator on the upstream side of the valve.**
If excessive carbon dust is generated by the compressor, it may adhere to the inside of a valve and cause it to malfunction.

3. Counting the operating cycle

- When counting the operating cycles using an auto switch, use an instrument with a counting speed of 1 kHz or more.



VBAE Series

Specific Product Precautions 2

Be sure to read this before handling the products. Refer to the back cover for safety instructions. For F.R.L. units and auto switch precautions, refer to the “Handling Precautions for SMC Products” and the “Operation Manual” on the SMC website: <https://www.smcworld.com>

Selection

Caution

1. Selection

- Based on the conditions (such as pressure, flow rate, and cycle time) required for the outlet side of the booster regulator, check the selection procedures described in this catalog or model selection software for size selection of the booster regulator. Please use the Booster Regulator Model Selection software on the SMC website: <https://mssc.smcworld.com/brmss/>
- When operating the booster regulator continuously for longer periods of time, particularly confirm its service life.
- The service life of the booster regulator depends on not the operation hours but the operating cycles (piston sliding distance). The operating cycles (piston sliding distance) depend on the outlet air flow rate of the booster regulator. Thus, when more outlet air flow rate of the booster regulator is used, its service life becomes shorter. Selecting a booster regulator of a larger size will result in reduced operation frequency, thus increasing the service life of the product.
- When using 2 booster regulators for 2-stage pressure boost, be sure to provide a stable supply of pressure to the downstream booster regulator, and install a pressure vessel such as an air tank, etc., between the booster regulators. (Refer to “Circuit Example” on page 9.)

Mounting

Caution

1. Transporting

- When transporting this product, hold it lengthwise with both hands.

2. Mounting

- Tighten the mounting bolts for installation according to the table below since the piston vibration will transfer when installed.

Model	Bolt	Tightening torque
VBAE10	M5 x 0.8	3 N·m
VBAE20	M10 x 1.5	24 N·m

- If the transmission of vibration is not preferred, insert an isolating rubber material before installation.
- Mount the pressure gauge with a torque of 7 to 9 N·m.

Operating Environment

Caution

1. Installation location

- Do not install this product in an area that is exposed to rainwater or direct sunlight.
- Do not install in locations influenced by vibrations.
- If the booster regulator is frequently operated in a high-temperature, humid environment, condensation may be generated on the outside of the booster regulator.

Safety Instructions

These safety instructions are intended to prevent hazardous situations and/or equipment damage. These instructions indicate the level of potential hazard with the labels of “**Caution**,” “**Warning**” or “**Danger**.” They are all important notes for safety and must be followed in addition to International Standards (ISO/IEC)*1), and other safety regulations.

⚠ Danger : **Danger** indicates a hazard with a high level of risk which, if not avoided, will result in death or serious injury.

⚠ Warning: **Warning** indicates a hazard with a medium level of risk which, if not avoided, could result in death or serious injury.

⚠ Caution: **Caution** indicates a hazard with a low level of risk which, if not avoided, could result in minor or moderate injury.

*1) ISO 4414: Pneumatic fluid power - General rules and safety requirements for systems and their components
ISO 4413: Hydraulic fluid power - General rules and safety requirements for systems and their components
IEC 60204-1: Safety of machinery - Electrical equipment of machines - Part 1: General requirements
ISO 10218-1: Robots and robotic devices - Safety requirements for industrial robots - Part 1: Robots etc.

Warning

1. The compatibility of the product is the responsibility of the person who designs the equipment or decides its specifications.

Since the product specified here is used under various operating conditions, its compatibility with specific equipment must be decided by the person who designs the equipment or decides its specifications based on necessary analysis and test results. The expected performance and safety assurance of the equipment will be the responsibility of the person who has determined its compatibility with the product. This person should also continuously review all specifications of the product referring to its latest catalog information, with a view to giving due consideration to any possibility of equipment failure when configuring the equipment.

2. Only personnel with appropriate training should operate machinery and equipment.

The product specified here may become unsafe if handled incorrectly. The assembly, operation and maintenance of machines or equipment including our products must be performed by an operator who is appropriately trained and experienced.

3. Do not service or attempt to remove product and machinery/equipment until safety is confirmed.

1. The inspection and maintenance of machinery/equipment should only be performed after measures to prevent falling or runaway of the driven objects have been confirmed.
2. When the product is to be removed, confirm that the safety measures as mentioned above are implemented and the power from any appropriate source is cut, and read and understand the specific product precautions of all relevant products carefully.
3. Before machinery/equipment is restarted, take measures to prevent unexpected operation and malfunction.

4. Our products cannot be used beyond their specifications. Our products are not developed, designed, and manufactured to be used under the following conditions or environments. Use under such conditions or environments is not covered.

1. Conditions and environments outside of the given specifications, or use outdoors or in a place exposed to direct sunlight.
2. Use for nuclear power, railways, aviation, space equipment, ships, vehicles, military application, equipment affecting human life, body, and property, fuel equipment, entertainment equipment, emergency shut-off circuits, press clutches, brake circuits, safety equipment, etc., and use for applications that do not conform to standard specifications such as catalogs and operation manuals.
3. Use for interlock circuits, except for use with double interlock such as installing a mechanical protection function in case of failure. Please periodically inspect the product to confirm that the product is operating properly.

Caution

We develop, design, and manufacture our products to be used for automatic control equipment, and provide them for peaceful use in manufacturing industries.

Use in non-manufacturing industries is not covered.

Products we manufacture and sell cannot be used for the purpose of transactions or certification specified in the Measurement Act.

The new Measurement Act prohibits use of any unit other than SI units in Japan.

Limited warranty and Disclaimer/ Compliance Requirements

The product used is subject to the following “Limited warranty and Disclaimer” and “Compliance Requirements”.

Read and accept them before using the product.

Limited warranty and Disclaimer

1. The warranty period of the product is 1 year in service or 1.5 years after the product is delivered, whichever is first.*2)
Also, the product may have specified durability, running distance or replacement parts. Please consult your nearest sales branch.
2. For any failure or damage reported within the warranty period which is clearly our responsibility, a replacement product or necessary parts will be provided. This limited warranty applies only to our product independently, and not to any other damage incurred due to the failure of the product.
3. Prior to using SMC products, please read and understand the warranty terms and disclaimers noted in the specified catalog for the particular products.

*2) **Vacuum pads are excluded from this 1 year warranty.**

A vacuum pad is a consumable part, so it is warranted for a year after it is delivered.

Also, even within the warranty period, the wear of a product due to the use of the vacuum pad or failure due to the deterioration of rubber material are not covered by the limited warranty.

Compliance Requirements

1. The use of SMC products with production equipment for the manufacture of weapons of mass destruction (WMD) or any other weapon is strictly prohibited.
2. The exports of SMC products or technology from one country to another are governed by the relevant security laws and regulations of the countries involved in the transaction. Prior to the shipment of a SMC product to another country, assure that all local rules governing that export are known and followed.

Safety Instructions

Be sure to read the “Handling Precautions for SMC Products” (M-E03-3) and “Operation Manual” before use.

SMC Corporation

Akihabara UDX 15F,
4-14-1, Sotokanda, Chiyoda-ku, Tokyo 101-0021, JAPAN
Phone: 03-5207-8249 Fax: 03-5298-5362
<https://www.smcworld.com>
© 2024 SMC Corporation All Rights Reserved

Specifications are subject to change without prior notice and any obligation on the part of the manufacturer.

D-G