

# Electric Gripper for Collaborative Robots

New

Can be used with the collaborative robots of  
**UNIVERSAL ROBOTS, FANUC CORPORATION, and  
 OMRON/TECHMAN ROBOT**



## Plug and Play



When closed 0 mm  
 When open 50 mm



\* The attachment should be ordered separately by the customer.

■ Gripping force: 60 to 140 N

Annual CO<sub>2</sub> emissions:  
 Max. **52%** reduction (SMC comparison)

p. 1

9.8 kg-CO<sub>2</sub>e/year (20.6)

\* The numerical values vary depending on the operating conditions.

### Basic Type

Operate by simply connecting 1 electrical cable

M8 connector

56 mm

With rounded protective cover

Low load on the robot due to short distance between the mounting position and gripping point

### Longitudinal Type

63 mm

Use in narrow spaces

- With internal battery-less absolute encoder
- Compatible plug-in software **p. 1**

## LEHR Series



CAT.ES160-10A B

# Electric Gripper for Collaborative Robots *LEHR Series*

Annual CO<sub>2</sub> emissions reduced by up to **52%** through motor control optimization (SMC comparison)

<Operating conditions>

Speed: 100 mm/s      Acceleration/Deceleration: 2000 mm/s<sup>2</sup>  
 Duty ratio: 50%      Stroke: 50 mm  
 When energized 8 hours/day, 250 days/year

\* The numerical values vary depending on the operating conditions.

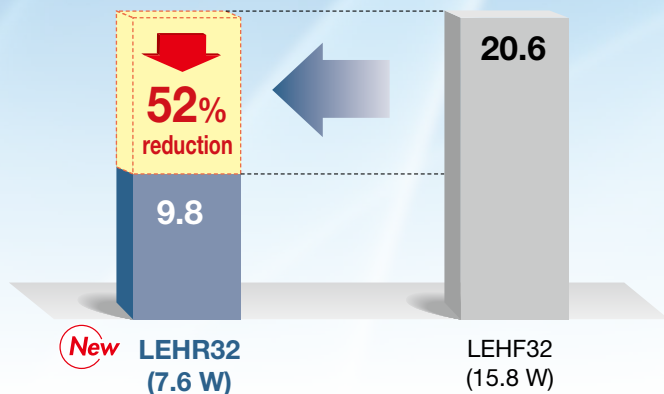

Easy tool changing (Manual changer)

- Tools can be secured by simply tightening the 2 clamber bolts.
- Reduces work-hours

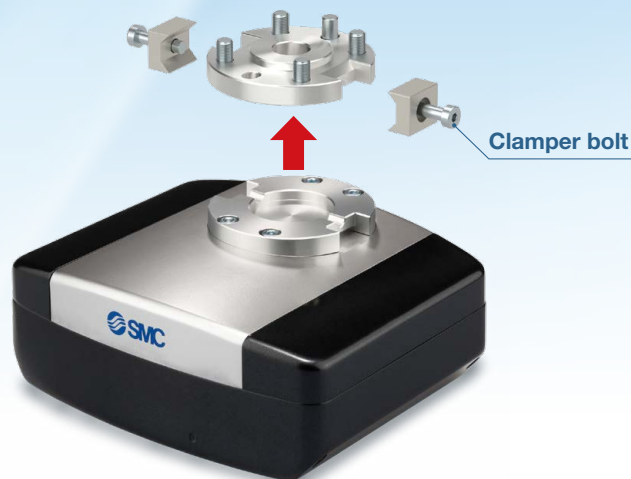

## Plug-in Software

Compatible with robots from UNIVERSAL ROBOTS, FANUC CORPORATION, and OMRON/TECHMAN ROBOT

### UNIVERSAL ROBOTS

URCap

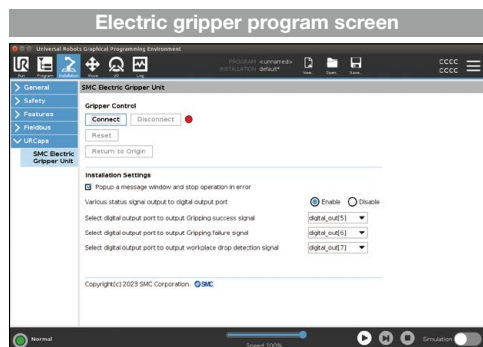

### FANUC

CRX Plug-in

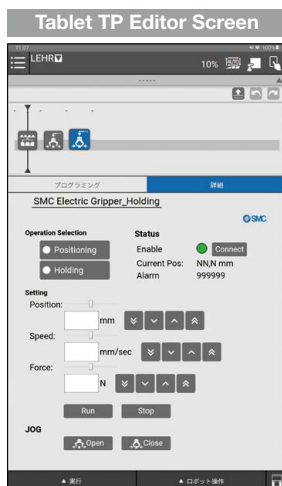

### OMRON/TECHMAN ROBOT

TMComponent

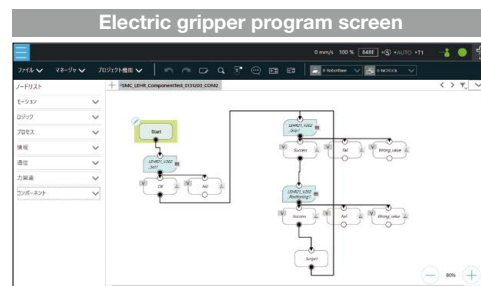

## CONTENTS

### Electric Gripper for Collaborative Robots *LEHR Series*

Model Selection .....	p. 2	Dimensions .....	p. 5
How to Order .....	p. 4	Specific Product Precautions .....	p. 7
Specifications .....	p. 4	Options .....	p. 7-1

# LEHR Series Model Selection

## Checking whether a workpiece can be transferred

### Selection Procedure

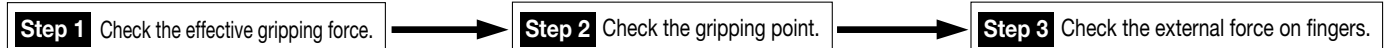

### Step 1 Check the gripping force.



### Example

Workpiece mass: 0.2 kg

Guidelines for gripping force with respect to workpiece mass

- Although conditions vary depending on the coefficient of friction between the attachment and the workpiece as well as the shape, adjust so that the gripping force is at least 5 to 10 times<sup>(\*)</sup> greater than the workpiece weight.
  - \*1 Refer to the gripping force calculation explanatory drawing for more information.
- Further allowance should be provided when great acceleration or impact is expected during workpiece transfer.
  - Example) For setting the gripping force to be at least 10 times greater than the workpiece weight:  
Required gripping force =  $0.2 \text{ kg} \times 10 \times 9.8 \text{ m/s}^2 \approx 19.6 \text{ N}$  or more

Gripping force setting value: 100 N

Gripping point: 50 mm

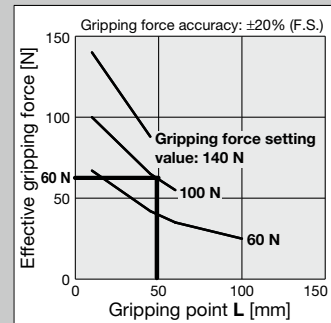

- Effective gripping force can be found to be 60 N from the intersection point of gripping point distance  $L = 50 \text{ mm}$  and gripping force setting value of 100 N.
- Since a effective gripping force of 60 N satisfies the required gripping force of 19.6 N or more, the workpiece can be transferred by the LEHR32K2-50□.

### Gripping force calculation explanatory drawing

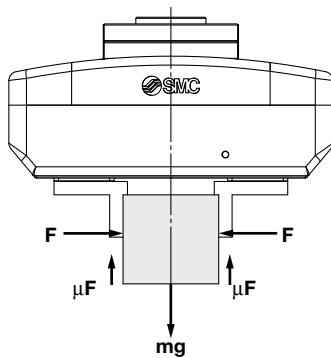

#### “Gripping force at least 5 to 10 times greater than the workpiece weight”

· The “at least 5 to 10 times greater than the workpiece weight” recommended by SMC is calculated with a margin of “a” = 2, which allows for impacts that occur during transfer by collaborative robots, etc.

When $\mu = 0.2$	When $\mu = 0.1$
$F = \frac{mg}{2 \times 0.2} \times 2$ $= 5 \times mg$	$F = \frac{mg}{2 \times 0.1} \times 2$ $= 10 \times mg$
5 x Workpiece weight	10 x Workpiece weight

- (\*) · Even in cases where the friction coefficient is greater than  $\mu = 0.2$ , for safety reasons, we recommend selecting a gripping force which is at least 5 to 10 times greater than the workpiece weight. However, to check whether a workpiece can be transferred under the actual conditions (finger shape, material, grip method, amount of acceleration, and ambient environment), the customer must conduct a workpiece transfer test.
- This product has a smaller margin than our standard grippers as it is designed for use with a collaborative robot (acceleration 1000 mm/s<sup>2</sup>, speed 250 mm/s). However, the gripping force margin should be increased in the following cases.
    - For large accelerations or impacts exceeding the above, a larger margin should be considered.
    - If the finger and workpiece contact surfaces are small, even if the gripping force is 5 to 10 times the workpiece weight, there is a risk of the workpiece falling. A material with a high coefficient of friction such as rubber is recommended for the end of the finger.
  - To check whether a workpiece can be transferred under the actual conditions (such as the finger shape, material, grip method, amount of acceleration, and ambient environment), the customer must conduct a workpiece transfer test.

When gripping a workpiece as in the figure to the left, and with the following definitions,

**F** : Gripping force [N]

$\mu$  : Coefficient of friction between the attachments and the workpiece

**m** : Workpiece mass [kg]

**g** : Gravitational acceleration (= 9.8 m/s<sup>2</sup>)

**mg** : Workpiece weight [N]

the conditions under which the workpiece will not drop are

$$2 \times \mu F > mg$$

↑  
Number of fingers

and therefore,

$$F > \frac{mg}{2 \times \mu}$$

With “a” representing the margin, “F” is determined by the following formula:

$$F = \frac{mg}{2 \times \mu} \times a$$

## Checking whether a workpiece can be transferred / LEHR

### Step 1 Check the effective gripping force.

The gripping force shown in the graphs represents the gripping force of one finger when all fingers and attachments are in contact with the workpiece.  
 F = One finger thrust

#### Gripping state

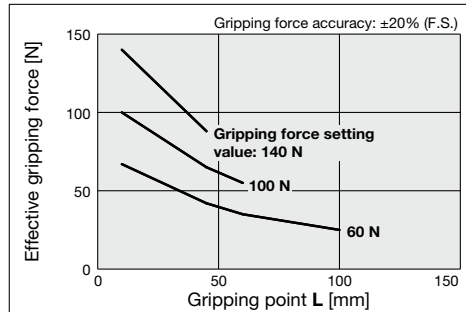
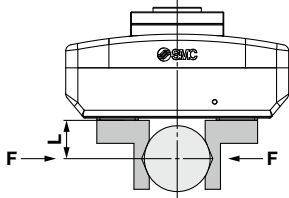

### Step 2 Check the gripping point.

- The air gripper should be operated so that the workpiece gripping point "L" and the amount of overhang "H" stay within the range shown for each operating pressure given in the graphs below.
- If the workpiece gripping point goes beyond the range limits, this will have an adverse effect on the life of the electric gripper.

#### Gripping state

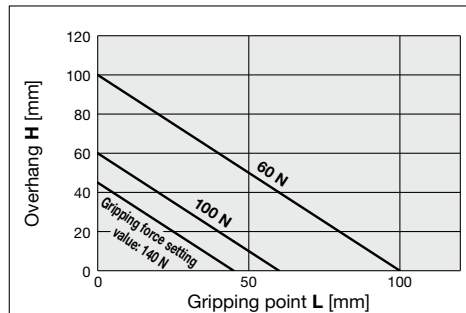
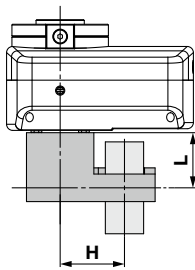

### Step 3 Check the external force on fingers.

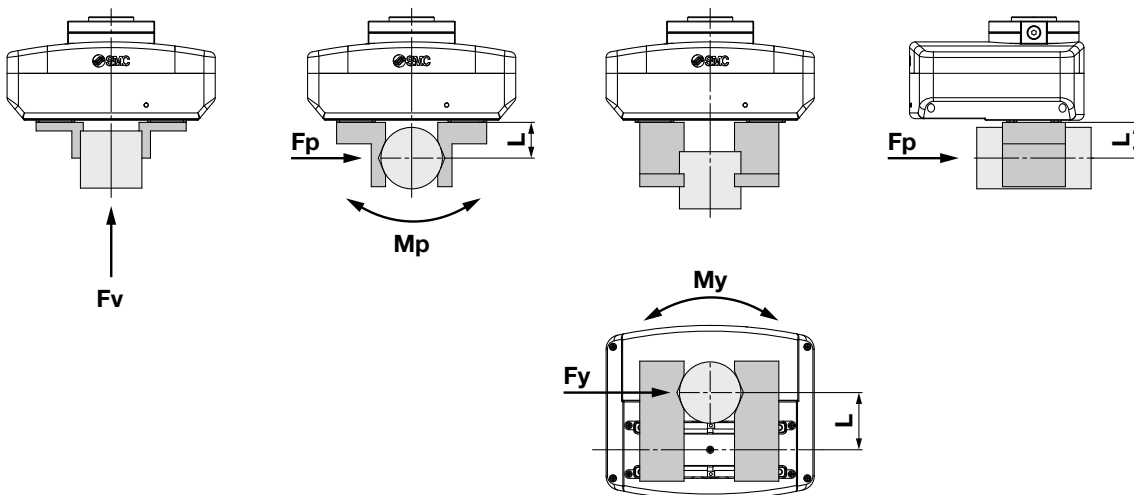

Model	Max. allowable moment/load*1, *2			
	Vertical load <b>Fvmax</b> (N)	Pitch moment <b>Mpmax</b> (N·m)	Yaw moment <b>Mymax</b> (N·m)	Roll moment <b>Mrmx</b> (N·m)
<b>LEHR32-50</b>	176	1.4	1.4	1.6

\*1 Inertial loads will be generated at the stroke end when the product is used for transportation. Consider the rate of acceleration.

\*2 Ensure moments and loads are the allowable values or less.

\* When combining a vertical load and moment, make sure the load factor is 1 or less according to the equation below.

$$F_v/F_{vmax} + M_p/M_{pmax} + M_y/M_{ymax} + M_r/M_{rmx} \leq 1 \text{ (Load factor)}$$

# Electric Gripper for Collaborative Robots

# LEHR Series



## How to Order

LEHR32K2-50 **A**-**011**-**N****E**

①      ②      ③      ④

### ① Actuator shape

<b>A</b>	Basic type
<b>B</b>	Longitudinal type

### ③ Robot connection cable

<b>Nil</b>	With connector cable (220 mm)
<b>N</b>	Without connection cable

### ② Compatible robot



Refer to the "Table 1 Compatible Robot List."

**Table 1 Compatible Robot List**

Identification symbol	Robot manufacturer	Supported model
011	UNIVERSAL ROBOTS	UR3(e)
		UR5(e)
		UR10(e)
		UR16e
021	OMRON TECHMAN ROBOT*1	TM5S
		TM7S
		TM12S
		TM14S
		TM25S
051	FANUC	CRX-5iA
		CRX-10iA(L)
		CRX-20iA
		CRX-25iA

\*1 TM S series  
(Only supports HW5.0 or higher)

### ④ Manual changer

<b>E</b>	With main plate assembly	
<b>F</b>	Without main plate assembly	

### Replacement Parts

Order no.	Description
Refer to page 7-1.	Robot connection cable
RMTM2-4M1	Manual changer Main plate assembly

The main plate assembly is required to mount the gripper to the robot. In addition, when the main plate assembly is mounted to the robot, several different tool models can be used with the robot. Customers who already have a main plate assembly can select option "F" (Without main plate assembly).

## Specifications

<b>Actuator</b>	<b>Open and close stroke [mm]</b>	50
	<b>Gripping force [N]</b>	60 to 140
	<b>Open and close speed/Gripping speed [mm/s]*1, *2</b>	5 to 100 / 5 to 30
	<b>Drive method</b>	Slide screw + Belt
	<b>Finger guide type</b>	Sliding bearing
	<b>Finger backlash/one side [mm]*3</b>	0.5 or less
	<b>Positioning repeatability/one side [mm]</b>	±0.1
	<b>Lost motion/one side [mm]*4</b>	0.5 or less
	<b>Impact/Vibration resistance [m/s<sup>2</sup>]*5</b>	150 / 5
	<b>Operating temperature range [°C]</b>	5 to 40
	<b>Operating humidity range [%RH]</b>	90 or less (No condensation)
<b>Electric specifications</b>	<b>Enclosure</b>	IP20
	<b>Weight [kg]</b>	1
	<b>Connector type</b>	M8, 8-pin (Plug)
	<b>Motor type</b>	Battery-less absolute (Step motor 24 VDC)
	<b>Encoder</b>	Battery-less absolute
<b>Power supply voltage [V]</b>	24	
<b>Power [W]*6</b>	Max. power 48	

\*1 Gripping force accuracy should be ±20% (F.S.). Gripping with heavy attachment and fast pushing speed, may not reach the product specification. In this case, decrease the weight and lower the pushing speed.

\*2 Gripping speed should be set within the range during gripping operations. Otherwise, it may cause a malfunction.

The open/close speed and gripping speed are for both fingers. The speed for one finger is half this value.

\*3 There will be no influence of backlash during gripping operations.

Make the stroke longer for the amount of backlash when opening.

\*4 A reference value for correcting errors in reciprocal operation which occur during positioning operations

\*5 Impact resistance: No malfunction occurred when the gripper was tested with a drop tester in both an axial direction and a perpendicular direction to the lead screw. (The test was performed with the gripper in the initial state.)

Vibration resistance: No malfunction occurred in a test ranging between 45 to 2000 Hz. The test was performed in both an axial direction and a perpendicular direction to the lead screw. (The test was performed with the gripper in the initial state.)

\*6 Indicates the max. power

# LEHR Series

## Dimensions

### Basic type / LEHR32K2-50A

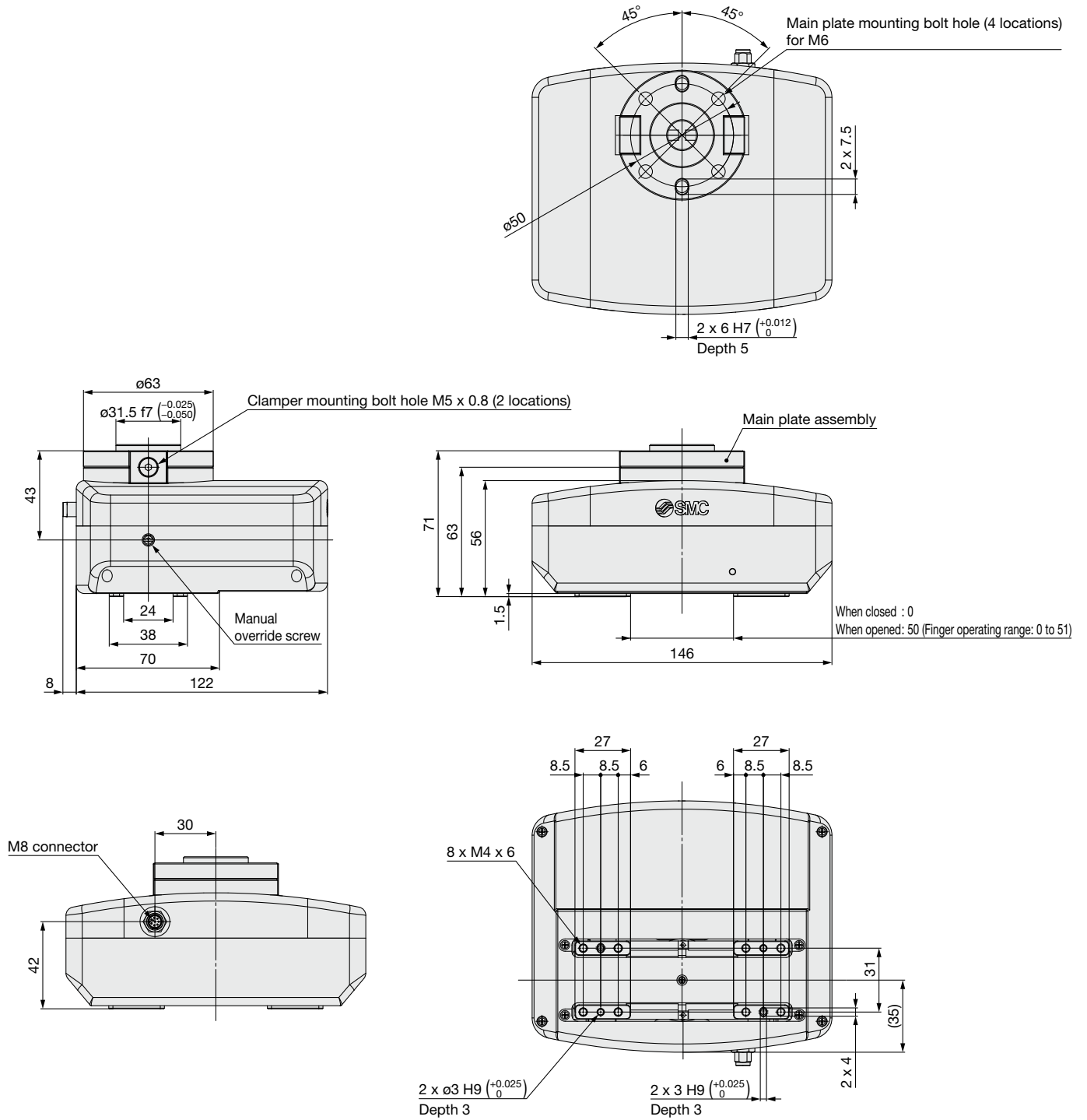

**Dimensions**

**Longitudinal type / LEHR32K2-50B**

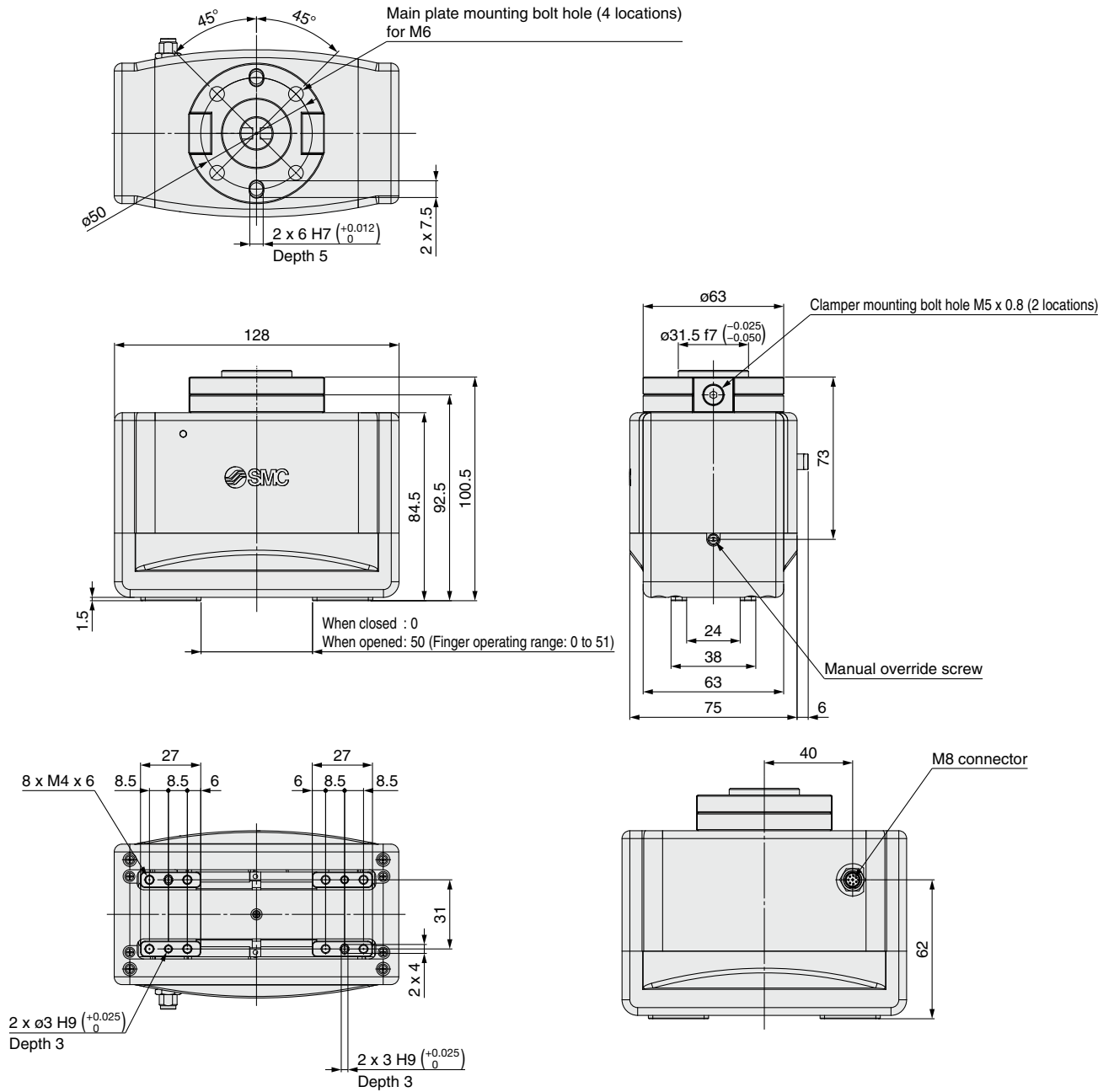



## LEHR Series

# Specific Product Precautions

Be sure to read this before handling the products. Refer to the back cover for safety instructions. For electric actuator precautions, refer to the “Handling Precautions for SMC Products” and the “Operation Manual” on the SMC website: <https://www.smcworld.com>

### Mounting

**1. Do not drop or hit the gripper to avoid scratching and denting the mounting surfaces.**

Even slight deformation may result in the deterioration of accuracy and operation failure.

**2. When mounting the attachment, tighten the mounting screws within the specified torque range.**

Tightening the screws with a higher torque than recommended may result in a malfunction, while tightening with a lower torque may result in the displacement of the mounting position or, in extreme conditions, the actuator could become detached from its mounting position.

Screw size	Tightening torque [N·m]
M4 x 0.7	1.35 to 1.65

### Handling

**1. In environments where strong magnetic fields are present, use may be limited.**

A magnetic sensor is used in the encoder. Therefore, if the actuator motor is used in an environment where strong magnetic fields are present, malfunction or failure may occur. Do not expose the actuator motor to magnetic fields with a magnetic flux density of 1 mT or more.



# LEHR Series Options

## Robot Compatible Connector Cable

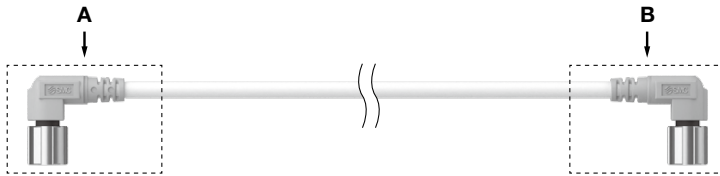

Identification symbol	Robot manufacturer	A Gripper side	B Robot side	Part no.
011	UNIVERSAL ROBOTS	M8 8-pin connector (Socket)	M8 8-pin connector (Socket)	RMH-A00-11-A
021	OMRON/TECHMAN ROBOT		M8 8-pin connector (Plug)	RMH-A00-11-B
051	FANUC		M8 8-pin connector (Socket)	RMH-A00-11-A

## How to Mount the Manual Changer

1. Insert the positioning pin into the robot arm, and tighten the main plate with the hexagon socket head cap screws.  
(Tightening torque: 4.7 to 5.7 N·m)
2. Loosen the clamber bolt, and align it with the tool plate groove on the air gripper.
3. Tighten the clamber bolts.  
(Tightening torque: 2.7 to 3.3 N·m)

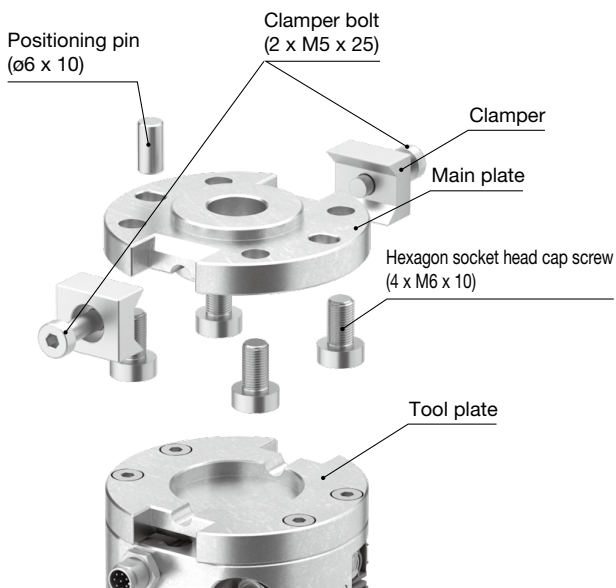

## Safety Instructions

These safety instructions are intended to prevent hazardous situations and/or equipment damage. These instructions indicate the level of potential hazard with the labels of “**Caution**,” “**Warning**” or “**Danger**.” They are all important notes for safety and must be followed in addition to International Standards (ISO/IEC)\*1), and other safety regulations.

 **Danger :** **Danger** indicates a hazard with a high level of risk which, if not avoided, will result in death or serious injury.

 **Warning:** **Warning** indicates a hazard with a medium level of risk which, if not avoided, could result in death or serious injury.

 **Caution:** **Caution** indicates a hazard with a low level of risk which, if not avoided, could result in minor or moderate injury.

\*1) ISO 4414: Pneumatic fluid power - General rules and safety requirements for systems and their components  
ISO 4413: Hydraulic fluid power - General rules and safety requirements for systems and their components  
IEC 60204-1: Safety of machinery - Electrical equipment of machines - Part 1: General requirements  
ISO 10218-1: Robots and robotic devices - Safety requirements for industrial robots - Part 1: Robots etc.

### Warning

#### 1. The compatibility of the product is the responsibility of the person who designs the equipment or decides its specifications.

Since the product specified here is used under various operating conditions, its compatibility with specific equipment must be decided by the person who designs the equipment or decides its specifications based on necessary analysis and test results. The expected performance and safety assurance of the equipment will be the responsibility of the person who has determined its compatibility with the product. This person should also continuously review all specifications of the product referring to its latest catalog information, with a view to giving due consideration to any possibility of equipment failure when configuring the equipment.

#### 2. Only personnel with appropriate training should operate machinery and equipment.

The product specified here may become unsafe if handled incorrectly. The assembly, operation and maintenance of machines or equipment including our products must be performed by an operator who is appropriately trained and experienced.

#### 3. Do not service or attempt to remove product and machinery/equipment until safety is confirmed.

1. The inspection and maintenance of machinery/equipment should only be performed after measures to prevent falling or runaway of the driven objects have been confirmed.
2. When the product is to be removed, confirm that the safety measures as mentioned above are implemented and the power from any appropriate source is cut, and read and understand the specific product precautions of all relevant products carefully.
3. Before machinery/equipment is restarted, take measures to prevent unexpected operation and malfunction.

#### 4. Our products cannot be used beyond their specifications. Our products are not developed, designed, and manufactured to be used under the following conditions or environments. Use under such conditions or environments is not covered.

1. Conditions and environments outside of the given specifications, or use outdoors or in a place exposed to direct sunlight.
2. Use for nuclear power, railways, aviation, space equipment, ships, vehicles, military application, equipment affecting human life, body, and property, fuel equipment, entertainment equipment, emergency shut-off circuits, press clutches, brake circuits, safety equipment, etc., and use for applications that do not conform to standard specifications such as catalogs and operation manuals.
3. Use for interlock circuits, except for use with double interlock such as installing a mechanical protection function in case of failure. Please periodically inspect the product to confirm that the product is operating properly.

### Caution

**We develop, design, and manufacture our products to be used for automatic control equipment, and provide them for peaceful use in manufacturing industries.**

**Use in non-manufacturing industries is not covered.**

Products we manufacture and sell cannot be used for the purpose of transactions or certification specified in the Measurement Act.

The new Measurement Act prohibits use of any unit other than SI units in Japan.

### Limited warranty and Disclaimer/ Compliance Requirements

The product used is subject to the following “Limited warranty and Disclaimer” and “Compliance Requirements”.

Read and accept them before using the product.

#### Limited warranty and Disclaimer

1. The warranty period of the product is 1 year in service or 1.5 years after the product is delivered, whichever is first.\*2)  
Also, the product may have specified durability, running distance or replacement parts. Please consult your nearest sales branch.
2. For any failure or damage reported within the warranty period which is clearly our responsibility, a replacement product or necessary parts will be provided. This limited warranty applies only to our product independently, and not to any other damage incurred due to the failure of the product.
3. Prior to using SMC products, please read and understand the warranty terms and disclaimers noted in the specified catalog for the particular products.

\*2) **Vacuum pads are excluded from this 1 year warranty.**

A vacuum pad is a consumable part, so it is warranted for a year after it is delivered.

Also, even within the warranty period, the wear of a product due to the use of the vacuum pad or failure due to the deterioration of rubber material are not covered by the limited warranty.

#### Compliance Requirements

1. The use of SMC products with production equipment for the manufacture of weapons of mass destruction (WMD) or any other weapon is strictly prohibited.
2. The exports of SMC products or technology from one country to another are governed by the relevant security laws and regulations of the countries involved in the transaction. Prior to the shipment of a SMC product to another country, assure that all local rules governing that export are known and followed.

## Safety Instructions

Be sure to read the “Handling Precautions for SMC Products” (M-E03-3) and “Operation Manual” before use.

## SMC Corporation

Akihabara UDX 15F,  
4-14-1, Sotokanda, Chiyoda-ku, Tokyo 101-0021, JAPAN  
Phone: 03-5207-8249 Fax: 03-5298-5362  
<https://www.smcworld.com>  
© 2024 SMC Corporation All Rights Reserved

Specifications are subject to change without prior notice and any obligation on the part of the manufacturer.

D-G