

Clamp Cylinder

CK□1 Series

ø40, ø50, ø63

CK1□-Z Series is to be discontinued at the end of February 2025.
Please select CK1□-Z1 Series instead. [▶ Click here for details.](#)

Total tube length reduced

RoHS

CKP1 Series
[Built-in strong magnet type]

Total tube length
reduced by

7 mm
(CKP1□40)

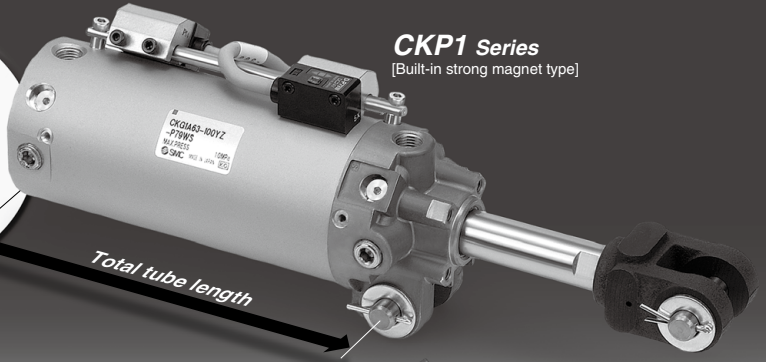

Easy speed adjustment

Speed controller valve

Easy fine speed adjustment with screw adjustment construction

Retaining construction with crimping

Hexagon
wrench

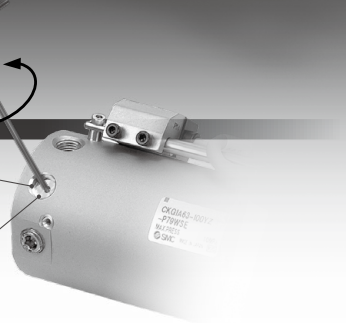

Clevis width

12.5 mm

16.5 mm/19.5 mm

Possible to select depending on the application

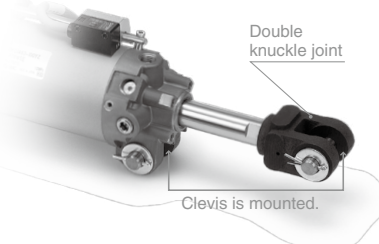

Double
knuckle joint

Clevis is mounted.

Magnetic field resistant auto switches

Mountable in 3 directions

[CKG1 series/Built-in standard magnet type]
D-P3DWA, D-P4DW

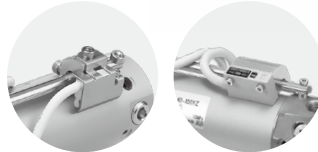

[CKP1 series/Built-in strong magnet type]
D-P79WSE, D-P74LZ

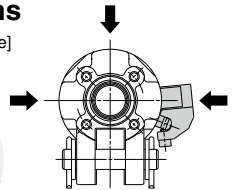
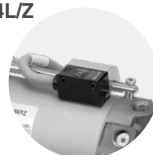

Total tube length reduced

The total length has been reduced by modifying the internal design.

CKP1 series (mm)			
Bore size (mm)	CKP1	Shortened dimensions	Current model
40	58	7	65
50	56	2	58
63	56	2	58

CKG1 series (mm)			
Bore size (mm)	CKG1	Shortened dimensions	Current model
40	53	2	55
50	56	2	58
63	56	2	58

Mounting dimensions are the same as the current product.

The dimension from the body to the work piece is the same as the current product.

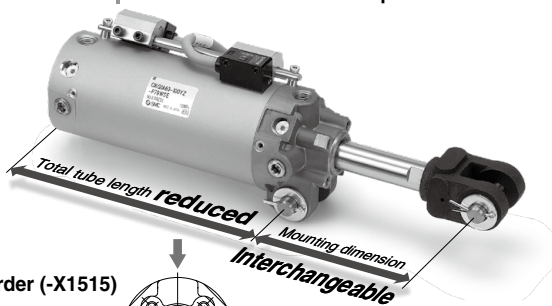

With air cushion

Unclamped side (Head end)...Standard
Air cushion on both ends.....Made to Order (-X1515)

Piping ports are located on three surfaces.

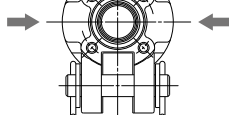

Possible to mount magnetic field resistant auto switch in 3 directions

[CKG1 series/Built-in standard magnet type]
D-P3DWASC, D-P3DWASE, D-P3DWA/LZ (AC magnetic field)
D-P4DWSC, D-P4DWSE, D-P4DWL/Z (AC magnetic field)

[CKP1 series/Built-in strong magnet type]
D-P79WSE, D-P74L/Z (DC/AC magnetic field)

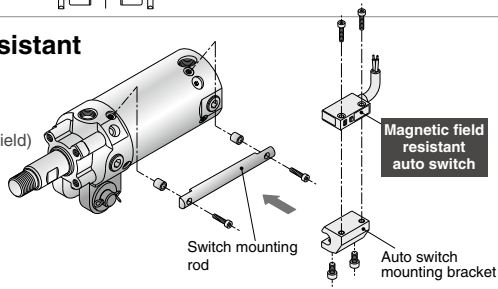

CK1 Series Variations

Series			Bore size (mm)					Stroke (mm)	Clevis width (mm)	Page
			25	32	40	50	63			
 Clamp cylinder (Rod mounting type)	Built-in standard magnet type	CKG1			●	●	50	12.5 16.5 19.5	P.437	
	Built-in strong magnet type	CKP1			●	●	75			
 Clamp cylinder (Band mounting type)	Without magnet	CK1			●	●	125			P.442
	Built-in standard magnet type	CKG1			●	●	150			
 Clamp cylinder/ Slim type (Rod mounting type)	Built-in standard magnet type	CKG□-X2095	●	●	●	●	200* *Except ø40	9, 12.5	P.491	
	Built-in strong magnet type	CKP□-X2095	●	●	●	●	50			
 Clamp cylinder with lock/Slim type (Rod mounting type)	Built-in standard magnet type	CLKG□-X2095	●	●	●	●	75			P.461
	Built-in strong magnet type	CLKP□-X2095	●	●	●	●	100			
 Clamp cylinder with lock	Built-in standard magnet type	CLK2G□		● ^{*1}	●	●	50, 75	12.5 16.5 19.5	P.461	
	Built-in strong magnet type	CLK2P□		●	●	●	100, 125			
					●	●	150			

Clamp Cylinder with Magnetic Field Resistant Auto Switch (Rod Mounting Type)

CKG1/CKP1 Series

ø40, ø50, ø63

RoHS

CK1□-Z Series is to be discontinued at the end of February 2025. Please select CK1□-Z1 Series instead. [Click here for details.](#)

How to Order

Built-in standard magnet

CKG1 A 50 □ - 100 Y □ Z - P3DWASC □ - □

Built-in strong magnet

CKP1 A 50 □ - 100 Y □ Z - P79WSE □ - □

Clevis width

A	16.5 mm
B	19.5 mm
C	12.5 mm

Bore size

40	40 mm
50	50 mm
63	63 mm

Thread type

Nil	Rc1/4
TN	NPT1/4
TF	G1/4

Cylinder stroke (mm)

40	50, 75, 100, 125, 150
50	50, 75, 100, 125, 150, 200
63	50, 75, 100, 125, 150, 200

Number of auto switches

Nil	2 pcs.
S	1 pc.
n	"n" pcs.

Made to Order
Refer to page 438 for details.

Auto switch

Nil	Without auto switch (built-in magnet) Without switch mounting rod
P	Without auto switch (built-in magnet) With switch mounting rod

* Select applicable auto switch models from the table below.

Built-in Standard (Strong) Magnet Cylinder Part No.

- 1) Built-in standard (strong) magnet without auto switch, without switch mounting rod

Symbol for the auto switch type is "Nil" as shown below.

CKG1: (Example) CKG1A50-50YZ
CKP1: (Example) CKP1A50-50YZ

- 2) Built-in standard (strong) magnet without auto switch, with switch mounting rod

Symbol for the auto switch type is "P" as shown below.

CKG1: (Example) CKG1A50-50YZ-P
CKP1: (Example) CKP1A50-50YZ-P

* The auto switch mounting bracket is not included.

End bracket

Nil	None
I	Single knuckle joint (M6 without tap)
IA	Single knuckle joint (M6 with tap)
Y	Double knuckle joint (M6 without tap)
YA	Double knuckle joint (M6 with tap)

Note) A knuckle pin, cotter pins and flat washers are provided as a standard for Y and YA.

Option

Nil	None
B	Limit switch mounting base Note 1)
D	Dog fitting Note 1)
L	Foot
K Note 2)	Pedestal (for 75, 100, 150 strokes only)

Note 1) Only IA or YA (M6 with tap) is selectable as the end bracket for the B, D, and BD types.

Note 2) Only available for clevis width A (16.5 mm)

Applicable Magnetic Field Resistant Auto Switches (Refer to pages 1341 to 1435 for detailed auto switch specifications.)

Applicable cylinder series	Type	Auto switch model	Applicable magnetic field	Electrical entry	Indicator light	Wiring (Pin no. in use)	Load voltage	Lead wire length	Applicable load
CKG1	Solid state auto switch	D-P3DWASC	AC magnetic field (Single-phase AC welding magnetic field)	Pre-wired connector	2-color indicator	2-wire (3-4)	24 VDC	0.3 m	Relay, PLC
		D-P3DWASE				2-wire (1-4)		0.5 m	
		D-P3DWA		Grommet		2-wire		3 m	
		D-P3DVAL						5 m	
		D-P3DWAZ		Pre-wired connector		2-wire (3-4)		0.3 m	
		D-P4DWSC				2-wire (1-4)		3 m	
		D-P4DWSE		Grommet		2-wire		5 m	
		D-P4DWL						5 m	
CKP1	Reed auto switch	D-P79WSE	DC/AC magnetic field	Pre-wired connector	2-color indicator	2-wire (1-4)	24 VDC	0.3 m	
		D-P74L		Grommet	1-color indicator	2-wire	24 VDC	3 m	
		D-P74Z					100 VAC	5 m	

Note 1) Refer to page 449 when ordering the auto switch mounting bracket or switch mounting rod assembly.

Note 2) For the D-P3DWA□, the auto switch and auto switch mounting bracket are packed together, (but not assembled).

CK□1 Series

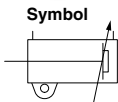
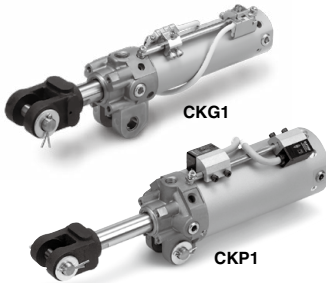

Refer to pages 448 to 451 for cylinders with auto switches.

- Minimum stroke for auto switch mounting
- Auto switch proper mounting position (detection at stroke end) and its mounting height
- Operating range
- Auto switch mounting bracket/Part no.

Made to Order
(Refer to page 452 for details.)

Symbol	Specifications
-X1515	With air cushion on both ends

Made to Order
[Click here for details](#)

Symbol	Specifications
-XC88*	Spatter resistant coil scraper, Lubretainer, Grease for welding (Rod parts: Stainless steel 304)
-XC89*	Spatter resistant coil scraper, Lubretainer, Grease for welding (Rod parts: S45C)
-XC91*	Spatter resistant coil scraper, Grease for welding (Rod parts: S45C)

* Not available for the CKP1 series.

Specifications

Bore size (mm)	40	50	63
Fluid	Air		
Proof pressure	1.5 MPa		
Maximum operating pressure	1.0 MPa		
Minimum operating pressure	0.05 MPa		
Ambient and fluid temperature	-10°C to 60°C		
Piston speed	50 to 500 mm/s		
Cushion	Unclamped side (head end): With air cushion		
Speed controller	Equipped on both ends		
Lubrication	Non-lube		
Stroke length tolerance	+1.0 0		
Mounting ^(Note)	Double clevis		

Note) A clevis pin, cotter pins, flat washers are equipped as a standard.

Clevis width	16.5 mm	CKG1A/CKP1A
	19.5 mm	CKG1B/CKP1B
	12.5 mm	CKG1C/CKP1C

Standard Stroke

Bore size (mm)	Standard stroke (mm)
40	50, 75, 100, 125, 150
50, 63	50, 75, 100, 125, 150, 200

End Bracket/Options

Symbol	Description	Part no.		
		CKG1A/CKP1A	CKG1B/CKP1B	CKG1C/CKP1C
I	Single knuckle joint	M6 without tap	CKB-I04	
IA		M6 with tap	CKB-IA04	
Y	Double knuckle joint (A knuckle pin, cotter pins, flat washers are equipped as a standard.)	M6 without tap	CKA-Y04	CKC-Y04
YA		M6 with tap	CKA-YA04	CKC-YA04

* For details about dimensions, refer to pages 446 and 447.

Weight (Basic weight includes the switch mounting rod. At 0 stroke)

Bore size (mm)		40	50	63	Unit: kg
CKG1□ cylinder	Basic weight	0.70	0.92	1.12	
	Additional weight per 25 mm of stroke	0.11	0.12	0.14	
CKP1□ cylinder	Basic weight	0.72	0.98	1.28	
	Additional weight per 25 mm of stroke	0.11	0.12	0.14	
Single knuckle joint					0.20
Double knuckle joint (A knuckle pin, cotter pins, flat washers are equipped as a standard.)					0.34

Calculation
Example) **CKG1□50-100YZ-P**

- Basic weight 0.92 (ø50)
- Additional weight 0.12/25 mm
- Cylinder stroke 100 mm
- Double knuckle joint 0.34 (Y)

0.92 + 0.12 x 100/25 + 0.34 = 1.74 kg

Theoretical Output

Bore size (mm)	Rod size (mm)	Operating direction	Piston area (mm ²)	Operating pressure (MPa)			
				0.3	0.4	0.5	0.6
40	20	OUT	1260	378	504	630	756
		IN	943	283	377	472	566
50	20	OUT	1960	588	784	980	1180
		IN	1650	495	660	825	990
63	20	OUT	3120	934	1250	1560	1870
		IN	2800	840	1120	1400	1680

Construction

CKG1□40, 50, 63 Rod mounting type

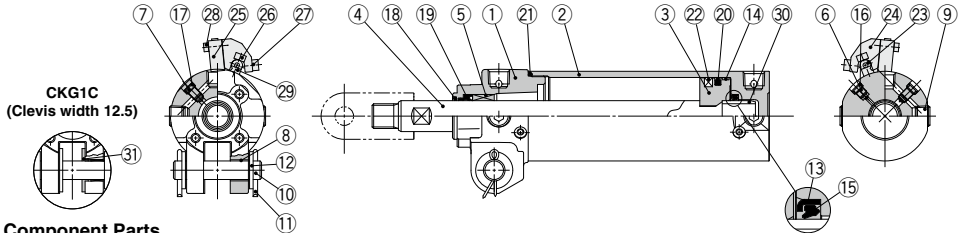

Component Parts

No.	Description	Material	Q'ty	Note
1	Rod cover	Aluminum alloy	1	Chromated
2	Tube cover	Aluminum alloy	1	Hard anodized
3	Piston	Aluminum alloy	1	Chromated
4	Piston rod	Carbon steel	1	Hard chrome plating
5	Bushing	Bearing alloy	1	
6	Cushion valve	Steel wire	1	Black zinc chromated
7	Speed controller valve	Steel wire	2	Nickel plating
8	Clevis bushing	Oil-impregnated sintered alloy	2	
9	Hexagon socket head plug	Carbon steel	4	Rc1/4
10	Pin	Carbon steel	1	
11	Cotter pin	Low carbon steel wire rod	2	
12	Flat washer	Rolled steel	2	
13	Cushion seal retainer	Rolled steel	1	Zinc chromated
14	Wear ring	Resin	1	
15	Cushion seal	Urethane	1	
16	Cushion valve seal	NBR	1	
17	Speed controller valve seal	NBR	2	

No.	Description	Material	Q'ty	Note
18	Coil scraper	Phosphor bronze	1	
19	Rod seal	NBR	1	
20	Piston seal	NBR	1	
21	Tube gasket	NBR	1	
22	Magnet	—	1	
23	Switch mounting rod	Carbon steel	1	Zinc chromated
24	Auto switch mounting bracket	Aluminum alloy	—	
25	Magnetic field resistant auto switch	—	—	
26	Hexagon socket head cap screw	Steel wire	2	M4 x 0.7 x 14 L
27	Hexagon socket head cap screw	Steel wire	2 pcs. per switch	M4 x 0.7 x 8 L
28	Hexagon socket head cap screw	Steel wire	2 pcs. per switch	M3 x 0.5 x 14 L
29	Switch mounting spacer	Aluminum alloy	2	
30	Cushion ring	Aluminum alloy	1	Anodized
31	Spacer	Bearing alloy	2	CKG1C only

CKP1□40, 50, 63 Rod mounting type

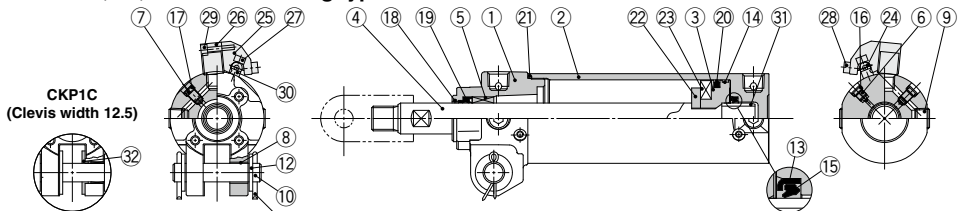

Replacement Parts/Seal Kit

Bore size (mm)	Order no.	Contents
40	CK1A40-PS	Set of nos. above (19, 20, 21).

Note 1) Seal kits are the same as those of the CKG□/CKP□.

Note 2) Seal kit does not come with a grease pack, so please order it separately.

Grease pack part number: GR-S-010
(compatible with all sizes)

Note 3) Cylinders with ø50 or larger bore sizes are tightened with a large tightening torque and cannot be disassembled. Please contact SMC when disassembly is required.

Component Parts

No.	Description	Material	Q'ty	Note
1	Rod cover	Aluminum alloy	1	Chromated
2	Tube cover	Aluminum alloy	1	Hard anodized
3	Piston	Aluminum alloy	1	Chromated
4	Piston rod	Carbon steel	1	Hard chrome plating
5	Bushing	Bearing alloy	1	
6	Cushion valve	Steel wire	1	Black zinc chromated
7	Speed controller valve	Steel wire	2	Nickel plating
8	Clevis bushing	Oil-impregnated sintered alloy	2	
9	Hexagon socket head plug	Carbon steel	4	Rc1/4
10	Pin	Carbon steel	1	
11	Cotter pin	Low carbon steel wire rod	2	
12	Flat washer	Rolled steel	2	
13	Cushion seal retainer	Rolled steel	1	Zinc chromated
14	Wear ring	Resin	1	
15	Cushion seal	Urethane	1	
16	Cushion valve seal	NBR	1	
17	Speed controller valve seal	NBR	2	

No.	Description	Material	Q'ty	Note
18	Coil scraper	Phosphor bronze	1	
19	Rod seal	NBR	1	
20	Piston seal	NBR	1	
21	Tube gasket	NBR	1	
22	Magnet holder	Aluminum alloy	1	
23	Magnet	—	1	
24	Switch mounting rod	Carbon steel	1	Zinc chromated
25	Auto switch mounting bracket	Aluminum alloy	—	
26	Magnetic field resistant auto switch	—	—	
27	Hexagon socket head cap screw	Steel wire	2	M4 x 0.7 x 14 L
28	Hexagon socket head cap screw	Steel wire	2 pcs. per switch	M4 x 0.7 x 8 L
29	Hexagon socket head cap screw	Steel wire	2 pcs. per switch	M3 x 0.5 x 16 L
30	Switch mounting spacer	Aluminum alloy	2	
31	Cushion ring	Aluminum alloy	1	Anodized
32	Spacer	Bearing alloy	2	CKP1C only

CK□1 Series

Dimensions

CKG1□40, 50, 63 Rod mounting type

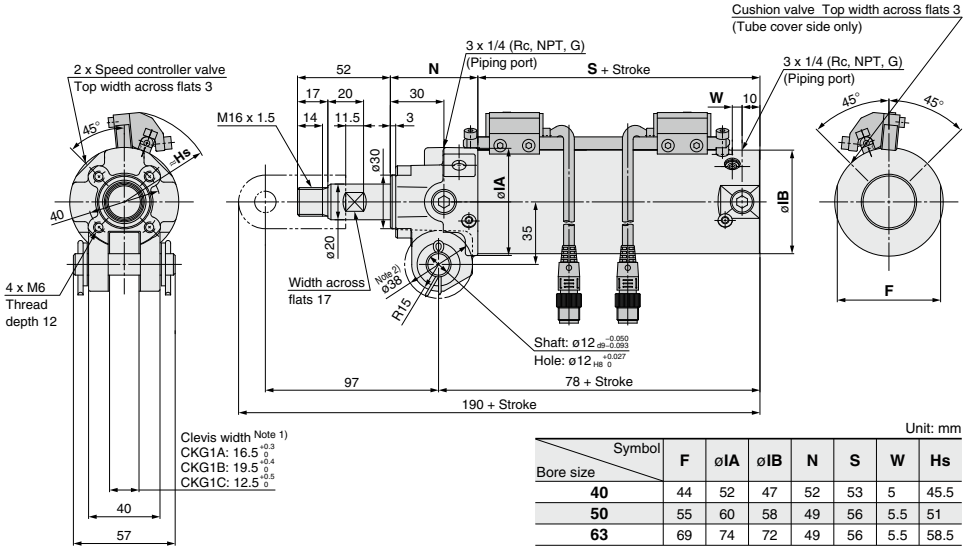

CKP1□40, 50, 63 Rod mounting type

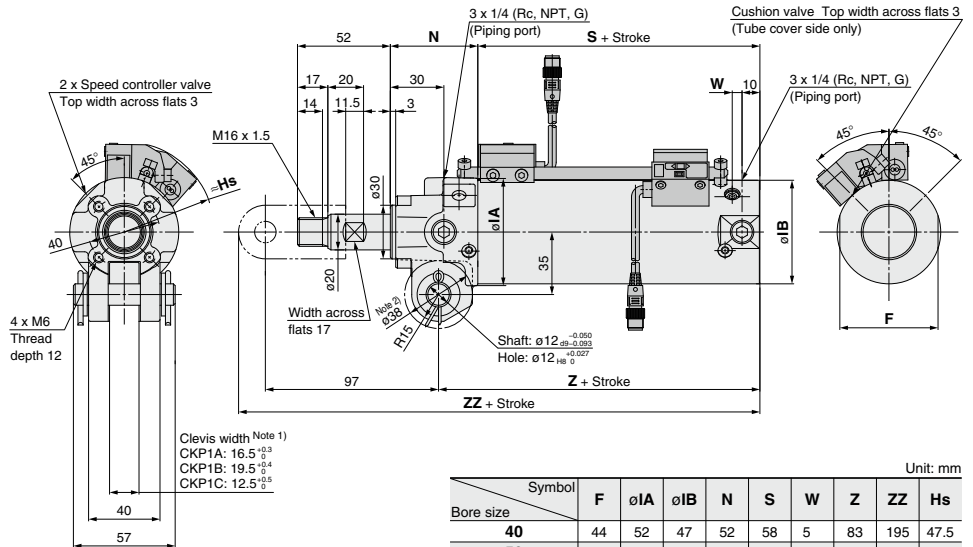

Clamp Cylinder with Magnetic Field Resistant Auto Switch (Band Mounting Type)

CK1/CKG1 Series

ø40, ø50, ø63

RoHS

How to Order

CK1 A 50 □ - 100 Y □ Z - □
 CKG1 A 50 □ - 100 Y □ Z - □

Built-in magnet for auto switch

Clevis width

A	16.5 mm
B	19.5 mm
C	12.5 mm

Bore size

40	40 mm
50	50 mm
63	63 mm

Thread type

NII	Rc1/4
TN	NPT1/4
TF	G1/4

Cylinder stroke (mm)

40	50, 75, 100, 125, 150
50	50, 75, 100, 125, 150, 200
63	50, 75, 100, 125, 150, 200

Option

NII	None
B	Limit switch mounting base <small>Note 1)</small>
D	Dog fitting <small>Note 1)</small>
L	Foot
K <small>Note 2)</small>	Pedestal (for 75, 100, 150 strokes only)

Note 1) Only IA or YA (M6 with tap) is selectable as the end bracket for the B, D, and BD types.
 Note 2) Only available for clevis width A (16.5 mm)

End bracket

NII	None
I	Single knuckle joint (M6 without tap)
IA	Single knuckle joint (M6 with tap)
Y	Double knuckle joint (M6 without tap)
YA	Double knuckle joint (M6 with tap)

Note) A knuckle pin, cotter pins and flat washers are provided as a standard for Y and YA.

Made to Order
 Refer to page 444 for details.

For how to order auto switch/switch mounting bracket, refer to the below.

Magnetic Field Resistant Auto Switch D-P4DW□/Band Mounting Compliant

Band mounting of the magnetic field resistant auto switch (D-P4DW□) to the CKG1□ series is possible by ordering the switch mounting bracket and the auto switch individually.



How to Order

Please order the switch mounting bracket, auto switch and clamp cylinder individually. Refer to the table below for auto switch mounting bracket part numbers.

Part no.	Applicable auto switch model	Applicable clamp cylinder
BA8-040	D-P4DWSC	CKG1□40
BA8-050	D-P4DWSE	CKG1□50
BA8-063	D-P4DWLZ	CKG1□63

Ordering Example

- Example case ① Cylinder: CKG1A50-50YZ 1
 Example case ② Magnetic field resistant auto switch:
 D-P4DWSC 2
 Example case ③ Switch mounting bracket: BA8-050 2

- Note 1) Please order the same quantity for the switch mounting bracket and the magnetic field resistant auto switch respectively.
 Note 2) Band mounting for the magnetic field resistant auto switches D-P79WS□, D-P74□ is not applicable.

Applicable Magnetic Field Resistant Auto Switches (Refer to pages 1341 to 1435 for detailed auto switch specifications.)

Applicable cylinder series	Type	Auto switch model	Applicable magnetic field	Electrical entry	Indicator light	Wiring (Pin no. in use)	Load voltage	Lead wire length	Applicable load
CKG1	Solid state auto switch	P4DWSC	AC magnetic field (Single-phase AC welding magnetic field)	Pre-wired connector	2-color indicator	2-wire (3-4)	24 VDC	0.3 m	Relay, PLC
		P4DWSE				2-wire (1-4)		3 m	
		P4DWL		2-wire	5 m				
		P4DWZ							

Clamp Cylinder with Standard Auto Switch (Band Mounting/Rod Mounting Type)

CKG1 Series

ø40, ø50, ø63

RoHS

How to Order

CKG1 **A** **50** - **100** **Y** **Z** - **M9BW** - - -

Built-in magnet for auto switch

Clevis width

A	16.5 mm
B	19.5 mm
C	12.5 mm

Bore size

40	40 mm
50	50 mm
63	63 mm

Thread type

Nil	Rc1/4
TN	NPT1/4
TF	G1/4

Cylinder stroke (mm)

40	50, 75, 100, 125, 150
50	50, 75, 100, 125, 150, 200
63	50, 75, 100, 125, 150, 200

End bracket

Nil	None
I	Single knuckle joint (M6 without tap)
IA	Single knuckle joint (M6 with tap)
Y	Double knuckle joint (M6 without tap)
YA	Double knuckle joint (M6 with tap)

(Note) A knuckle pin, cotter pins and flat washers are provided as a standard for Y and YA.

Auto switch mounting type

Nil	Band mounting
P	Rod mounting

Made to Order
Refer to page 444 for details.

Number of auto switches

Nil	2 pcs.
S	1 pc.

Auto switch

Nil	Without auto switch (Built-in magnet)
-----	---------------------------------------

* For applicable auto switches, refer to the table below.
* Auto switches are shipped together, (but not assembled).

Option

Nil	None
B	Limit switch mounting base (Note 1)
D	Dog fitting (Note 1)
L	Foot
K (Note 2)	Pedestal (for 75, 100, 150 strokes only)

Note 1) Only IA or YA (M6 with tap) is selectable as the end bracket for the B, D, and BD types.
Note 2) Only available for clevis width A (16.5 mm)



Standard Auto Switches Standard auto switches cannot be used under a strong magnetic field.

Type	Special function	Electrical entry	Indicator/light	Wiring (Output)	Load voltage		Auto switch model	Lead wire length [m]				Pre-wired connector	Applicable load			
					DC	AC		0.5 (Nil)	1 (M)	3 (L)	5 (Z)		IC circuit	Relay, PLC		
Solid state auto switch	—	Grommet	Yes	3-wire (NPN)	5 V, 12 V	—	M9N	●	●	●	○	○	IC circuit	Relay, PLC		
				3-wire (PNP)			M9P	●	●	●	○	○				
				2-wire	M9B		●	●	●	○	○					
	Diagnostic indication (2-color indicator)			Grommet	Yes		3-wire (NPN)	5 V, 12 V	M9NW	●	●	●	○		○	IC circuit
							3-wire (PNP)		M9PW	●	●	●	○		○	
							2-wire	M9BW	●	●	●	○	○			
	Water resistant (2-color indicator)	Grommet	Yes	3-wire (NPN)	5 V, 12 V	M9NA	○	○	●	○	○	IC circuit				
				3-wire (PNP)		M9PA	○	○	●	○	○					
				2-wire	M9BA	○	○	●	○	○						
Reed auto switch	—	Grommet	Yes	3-wire (NPN equivalent)	—	5 V	A96	●	—	●	—	—	IC circuit	—		
				2-wire	24 V	12 V	A93	●	●	●	●	—	—	Relay, PLC		
					5 V, 12 V	100 V or less	A90	●	—	●	—	—	—			

* Solid state auto switches marked with "O" are produced upon receipt of order.

* Auto switches and mounting brackets are shipped together, (but not assembled).

* Lead wire length symbols: 0.5 m.....Nil (Example) M9NWV
1 m.....M (Example) M9NWV
3 m.....L (Example) M9NWV
5 m.....Z (Example) M9NWV



Refer to pages 448 to 451 for cylinders with auto switches.

- Minimum stroke for auto switch mounting
- Auto switch proper mounting position (detection at stroke end) and its mounting height
- Operating range
- Auto switch mounting bracket/Part no.



Made to Order
(Refer to page 452 for details.)

Symbol	Specifications
-X1515	With air cushion on both ends

Made to Order

[Click here for details](#)

Symbol	Specifications
-XC88*	Spatter resistant coil scraper, Lubretainer, Grease for welding (Rod parts: Stainless steel 304)
-XC89*	Spatter resistant coil scraper, Lubretainer, Grease for welding (Rod parts: S45C)
-XC91*	Spatter resistant coil scraper, Grease for welding (Rod parts: S45C)

* Not available for the CK1 and CKG1 with the magnetic field resistant auto switch.

Specifications

Bore size (mm)	40	50	63
Fluid	Air		
Proof pressure	1.5 MPa		
Maximum operating pressure	1.0 MPa		
Minimum operating pressure	0.05 MPa		
Ambient and fluid temperature	Without auto switch: -10°C to 70°C With auto switch: -10°C to 60°C		
Piston speed	50 to 500 mm/s		
Cushion	Unclamped side (head end): With air cushion		
Speed controller	Equipped on both ends		
Lubrication	Non-lube		
Stroke length tolerance	+1.0 0		
Mounting ^(Note)	Double clevis		

Note) A clevis pin, cotter pins, flat washers are equipped as a standard.

Clevis width	16.5 mm	CK1A/CKG1A
	19.5 mm	CK1B/CKG1B
	12.5 mm	CK1C/CKG1C

Standard Stroke

Bore size (mm)	Standard stroke (mm)
40	50, 75, 100, 125, 150
50, 63	50, 75, 100, 125, 150, 200

End Bracket/Options

Symbol	Description	Part no.		
		CK1A/CKG1A	CK1B/CKG1B	CK1C/CKG1C
I	Single knuckle joint	M6 without tap	CKB-I04	
IA		M6 with tap	CKB-IA04	
Y	Double knuckle joint (A knuckle pin, cotter pins, flat washers are equipped as a standard.)	M6 without tap	CKA-Y04	CKC-Y04
YA		M6 with tap	CKA-YA04	CKC-YA04

* For details about dimensions, refer to pages 446 and 447.

Weight

		Unit: kg		
Bore size (mm)		40	50	63
Cylinder	Basic weight	0.68	0.90	1.10
	Additional weight per 25 mm of stroke	0.10	0.11	0.13
Single knuckle joint		0.20		
Double knuckle joint (A knuckle pin, cotter pins, flat washers are equipped as a standard.)		0.34		

Calculation

Example) **CKG1□50-100YZ**

- Basic weight 0.90 (ø50)
- Additional weight 0.11/25 mm
- Cylinder stroke 100 mm
- Double knuckle joint 0.34 (Y)

$$0.90 + 0.11 \times 100/25 + 0.34 = 1.68 \text{ kg}$$

Theoretical Output

		Unit: N					
Bore size (mm)	Rod size (mm)	Operating direction	Piston area (mm ²)	Operating pressure (MPa)			
				0.3	0.4	0.5	0.6
40	20	OUT	1260	378	504	630	756
		IN	943	283	377	472	566
50	20	OUT	1960	588	784	980	1180
		IN	1650	495	660	825	990
63	20	OUT	3120	934	1250	1560	1870
		IN	2800	840	1120	1400	1680

Construction

CK□1□40, 50, 63 Band mounting type

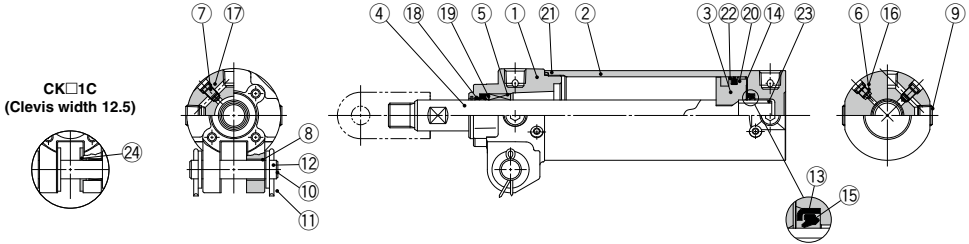

Component Parts

No.	Description	Material	Qty	Note
1	Rod cover	Aluminum alloy	1	Chromated
2	Tube cover	Aluminum alloy	1	Hard anodized
3	Piston	Aluminum alloy	1	Chromated
4	Piston rod	Carbon steel	1	Hard chrome plating
5	Bushing	Bearing alloy	1	
6	Cushion valve	Steel wire	1	Black zinc chromated
7	Speed controller valve	Steel wire	2	Nickel plating
8	Clevis bushing	Oil-impregnated sintered alloy	2	
9	Hexagon socket head plug	Carbon steel	4	Rc1/4
10	Pin	Carbon steel	1	
11	Cotter pin	Low carbon steel wire rod	2	
12	Flat washer	Rolled steel	2	
13	Cushion seal retainer	Rolled steel	1	Zinc chromated
14	Wear ring	Resin	1	
15	Cushion seal	Urethane	1	
16	Cushion valve seal	NBR	1	
17	Speed controller valve seal	NBR	2	
18	Coil scraper	Phosphor bronze	1	
19	Rod seal	NBR	1	
20	Piston seal	NBR	1	
21	Tube gasket	NBR	1	
22	Magnet	—	—	For the CKG1
23	Cushion ring	Aluminum alloy	1	Anodized
24	Spacer	Bearing alloy	2	CK□1C only

Replacement Parts/Seal Kit

Bore size (mm)	Order no.	Contents
40	CK1A40-PS	Set of nos. above (19, 20, 21).

Note 1) Seal kit does not come with a grease pack, so please order it separately.

Grease pack part number: GR-S-010 (compatible with all sizes)

Note 2) Cylinders with ø50 or larger bore sizes are tightened with a large tightening torque and cannot be disassembled. Please contact SMC when disassemble is required.

CK□1 Series

Dimensions

CK□1□40, 50, 63 Band mounting type

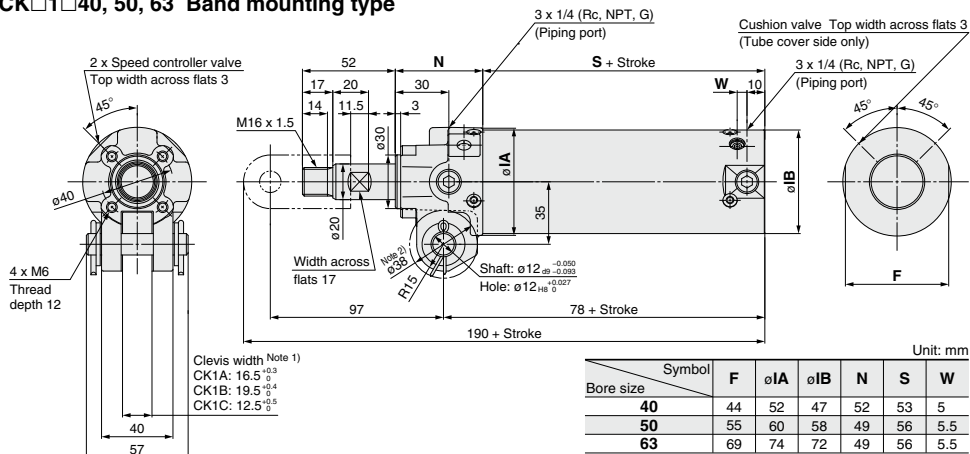

		Unit: mm					
Symbol		F	ø1A	ø1B	N	S	W
40	Bore size	44	52	47	52	53	5
50	Bore size	55	60	58	49	56	5.5
63	Bore size	69	74	72	49	56	5.5

Note 1) Indicates the point where the clevis is narrowest (on the tube side)
Note 2) Indicates the range applicable to the clevis width

End Bracket

Single Knuckle Joint

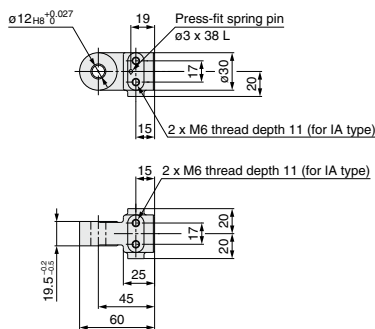

Material: Cast iron

Part no.	End bracket symbol	Applicable clamp cylinder
CKB-I04	I (M6 without tap)	CK□1A series
CKB-IA04	IA (M6 with tap)	CK□1B series

Note A) A spring pin is attached to the single knuckle joint as a standard.

Double Knuckle Joint

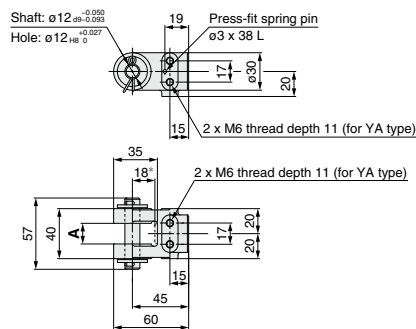

Material: Cast iron

Unit: mm

Part no.	End bracket symbol	A	Applicable clamp cylinder
CKA-Y04	Y (M6 without tap)	16.5 ₀ ^{+0.3}	CK□1A series
CKA-YA04	YA (M6 with tap)		
CKB-Y04	Y (M6 without tap)	19.5 ₀ ^{+0.4}	CK□1B series
CKB-YA04	YA (M6 with tap)		
CKC-Y04	Y (M6 without tap)	12.5 ₀ ^{+0.3}	CK□1C series
CKC-YA04	YA (M6 with tap)		

Note 1) A knuckle pin, cotter pins, flat washers and a spring pin are attached to the double knuckle joint as a standard.

Note 2) The dimension with * shows the value when mounted on the piston rod.

Pin

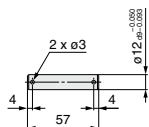

Material: Carbon steel

Part no.	Usage
CK-P04	Knuckle pin Clevis pin

Note) Cotter pins and flat washers are attached to the pin as a standard.

CK□1 Series

Auto Switch Mounting (Rod Mounting Type)

Auto Switch Proper Mounting Position (Detection at Stroke End) and Its Mounting Height

Rod mounting

D-P3DWA□

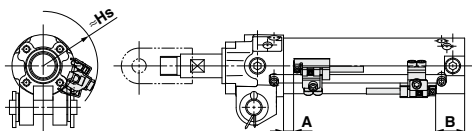

D-P4DW□

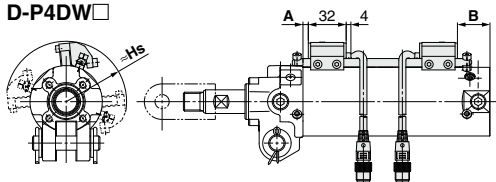

Note) The above drawing is the switch rod mounting example for the D-P4DWS□.

D-P79WSE

D-P74□

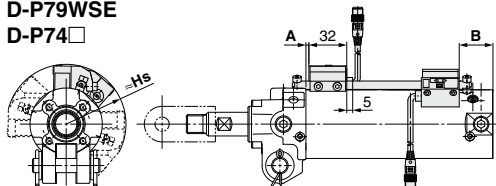

Note) The above drawing is the switch rod mounting example for the D-P79WSE.

D-M9□/M9□W

D-M9□A/A9□

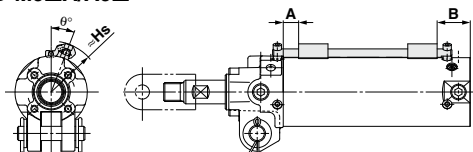

Note) The above drawing is the mounting example for the D-M9□ and D-A9□.

Auto Switch Mounting Position and Its Height:

Rod Mounting Type

Unit: mm

Auto switch model	Symbol	Auto switch set value and its height		
		ø40	ø50	ø63
D-P3DWA□	A	8.5	6	6
	B	23.5	29	29
	Hs	46.5	52	59
D-P4DW□	A	6	3.5	3.5
	B	21	26.5	26.5
	Hs	45.5	51	58.5
D-P79WSE	A	3	0.5	0.5
	B	18	23.5	23.5
D-P74□	Hs	47.5	51	57.5
	A	13	10.5	10.5
D-M9□	B	28	33.5	33.5
	Hs	39	44.5	51.5
D-M9□A	A	9	6.5	6.5
	B	24	29.5	29.5
	Hs	39	44.5	51.5

Note 1) The mounting position should be referred for reference only for the auto switch mounting position at the stroke end detection.

Adjust the auto switch after confirming the operation to set actually.

Note 2) The auto switch mounting position is temporarily set at the time of shipping from our factory. Change it to the desired position in accordance to your facility.

Note 3) For 2-color indication, mount the switch in the middle of the green indication.

Note 4) Adjust the auto switch after confirming the operating conditions in the actual setting.

Minimum Stroke for Auto Switch Mounting

Unit: mm

Auto switch model	With 1 pc.	With 2 pcs.	
		Different surfaces	Same surface
D-P3DWA□	50	50	50
D-P4DW□			
D-P79WSE			
D-P74□			

Note1) When two D-P3DWA□ are mounted to the cylinder with stroke 50 mm, mount them on different surfaces.

Note2) The standard strokes of CKG1 are 50, 75, 100, 125 and 150 mm. The values in the table above are not based on the minimum detection interval when setting the D-P3DWA auto switch, but on the standard minimum stroke of the cylinder.

Operating Range

Unit: mm

Auto switch model	Bore size		
	40	50	63
D-P3DWA□	5.5	5.5	5.5
D-P4DW□	4	4	4.5
D-P79WSE	8	9	9.5
D-P74□			
D-M9□	4	4.5	5
D-M9□W			
D-M9□A			
D-A9□	8	8	9

* Values which include hysteresis are for guideline purpose only, they are not a guarantee (assuming approximately ±30% dispersion) and may change substantially depending on the ambient environment.

Auto Switch Mounting Bracket/Part No.

Switch mounting rod assembly/Auto switch mounting bracket

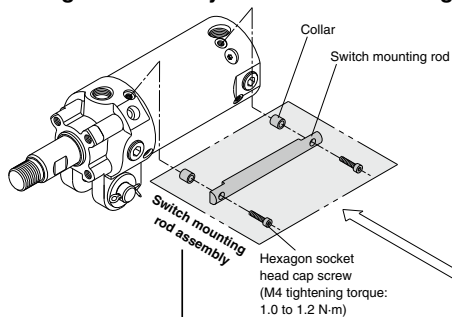

D-P3DWA□
D-P4DW□
D-P79W□*1
D-P74

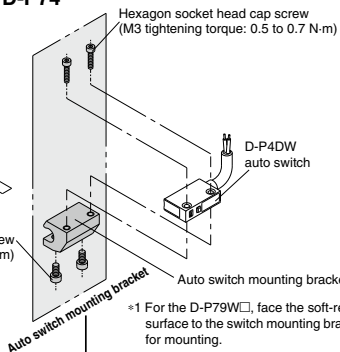

Switch Mounting Rod Assembly/Part No.

Applicable series	Applicable clamp cylinder	Part no.
Dedicated to CKP1□40	CKP1□40-50Z	CKP40-RZ050
	CKP1□40-75Z	CKP40-RZ075
	CKP1□40-100Z	CKP40-RZ100
	CKP1□40-125Z	CKP40-RZ125
	CKP1□40-150Z	CKP40-RZ150
CKG1□40/50/63	CKG1□40-50Z	CKG40-RZ050
	CKG1□50-50Z/CKP1□50-50Z	
	CKG1□63-50Z/CKP1□63-50Z	CKG40-RZ075
	CKG1□40-75Z	
	CKG1□50-75Z/CKP1□50-75Z	
CKG1□63-75Z/CKP1□63-75Z	CKG40-RZ100	
CKG1□40-100Z		
CKG1□50-100Z/CKP1□50-100Z		
CKG1□63-100Z/CKP1□63-100Z		
Common	CKG1□40-125Z	CKG40-RZ125
	CKG1□50-125Z/CKP1□50-125Z	
	CKG1□63-125Z/CKP1□63-125Z	
	CKG1□40-150Z	CKG40-RZ150
	CKG1□50-150Z/CKP1□50-150Z	
	CKG1□63-150Z/CKP1□63-150Z	
	CKG1□50-200Z/CKP1□50-200Z	CKG40-RZ200
	CKG1□63-200Z/CKP1□63-200Z	

D-M9□/M9□W
D-M9□A/A9□

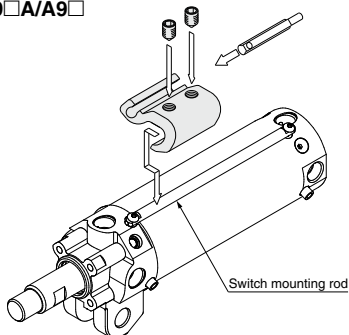

*1 For the D-P79W□, face the soft-resin mold surface to the switch mounting bracket side for mounting.

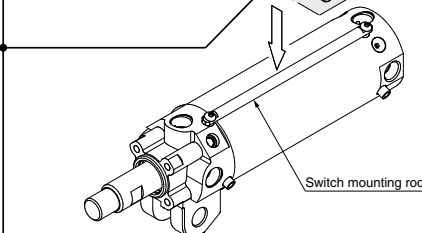
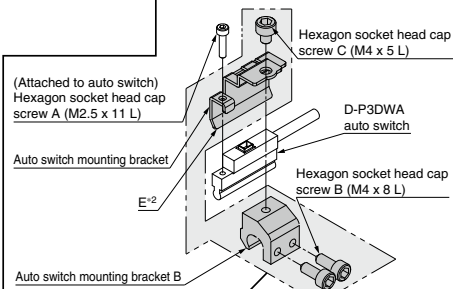

*2 Mount the part E of the auto switch mounting bracket so that it is in contact with the cylinder tube.
 Note 1) The tightening torque for a hexagon socket head cap screw (M2.5) is 0.2 to 0.3 N·m. Hold the shorter side of a hexagon wrench, and turn it to tighten. (Too much tightening may break the switch)
 Note 2) Tighten the hexagon socket head cap screws B and C (M4) with a tightening torque of 1 to 1.2 N·m.

Auto Switch Mounting Bracket/Part No.

Applicable cylinder series	Applicable auto switch model	Part no.		
		40	50	63
CKG1	D-P3DWA□	BK7-040S		
	D-P4DW□	BK1T-040		
	D-M9□	BA7-040		
	D-A9□	BA7-040		
CKP1	D-P79WSE	BAP1T-040		
	D-P74LZ	BAP1T-040		

Auto Switch Mounting (Band Mounting Type)

Auto Switch Mounting Position (Detection at Stroke End) and Its Mounting Height

Band mounting style

D-P4DW□

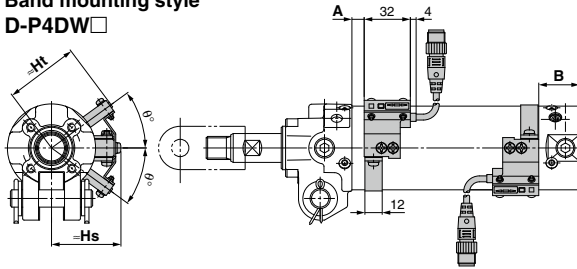

Note) The above drawing is the switch band mounting example for the D-P4DWS□.

D-M9□/M9□W

D-M9□A/A9□

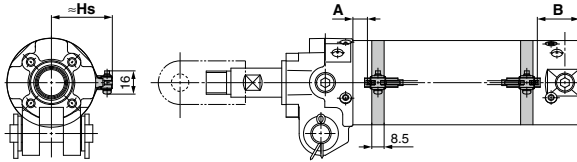

D-B54

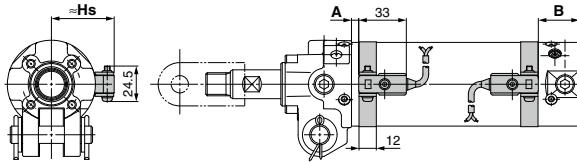

⚠ Caution

As for the precautions on the auto switches, product specifications, refer to pages 454 to 456.

Operating Range

Auto switch model	Bore size		
	40	50	63
D-P4DW□	5	5	5.5
D-M9□ D-M9□W D-M9□A	5.5	6.5	7
D-A9□	8	8	9
D-B54	10	10	11

Unit: mm

* Values which include hysteresis are for guideline purpose only, they are not a guarantee (assuming approximately ±30% dispersion) and may change substantially depending on the ambient environment.

Auto Switch Mounting Position and Its Height Unit: mm

Auto switch model	Symbol	Auto switch set value and its height		
		ø40	ø50	ø63
D-P4DW□	A	6	3.5	3.5
	B	21	26.5	26.5
	Hs	43	48	55
	Ht	46	51.5	58.5
	θ	40°	36°	33°
D-M9□ D-M9□W D-M9□A	A	13	10.5	10.5
	B	28	33.5	33.5
	Hs	35	40.5	47.5
D-A9□	A	9	6.5	6.5
	B	24	29.5	29.5
	Hs	35	40.5	47.5
D-B54	A	3.5	1	1
	B	18.5	24	24
	Hs	38	43.5	50.5

Note 1) The mounting position should be referred for reference only for the auto switch mounting position at the stroke end detection. Adjust the auto switch after confirming the operation to set actually.

Note 2) The auto switch mounting position is temporarily set at the time of shipping from our factory. Change it to the desired position in accordance to your facility.

Note 3) For the D-M9□/M9□W/M9□A/A9□, A and B are the dimensions from the end of the head cover/rod cover to the end of the auto switch.

Note 4) As for the D-P4DW□ type, band mounting type, the auto switch mounting bracket and the auto switch have to be ordered separately. For details, refer to page 442.

Note 5) For 2-color indication, mount the switch in the middle of the green indication.

Minimum Stroke for Auto Switch Mounting Unit: mm

Auto switch model	With 1 pc.	With 2 pcs.	
		Different surfaces	Same surface
D-P3DWA□	50	50	50
D-P4DW□			
D-P79WSE			
D-P74□			
D-M9□ D-M9□W D-M9□A			
D-A9□	50	50	75
D-B54	50	50	75

Note 1) When two D-P3DWA□ are mounted to the cylinder with stroke 50 mm, mount them on different surfaces.

Note 2) The standard strokes of CKG1 are 50, 75, 100, 125 and 150 mm. The values in the table above are not based on the minimum detection interval when setting the D-P3DWA auto switch, but on the standard minimum stroke of the cylinder.

Auto Switch Mounting Brackets/Part No.

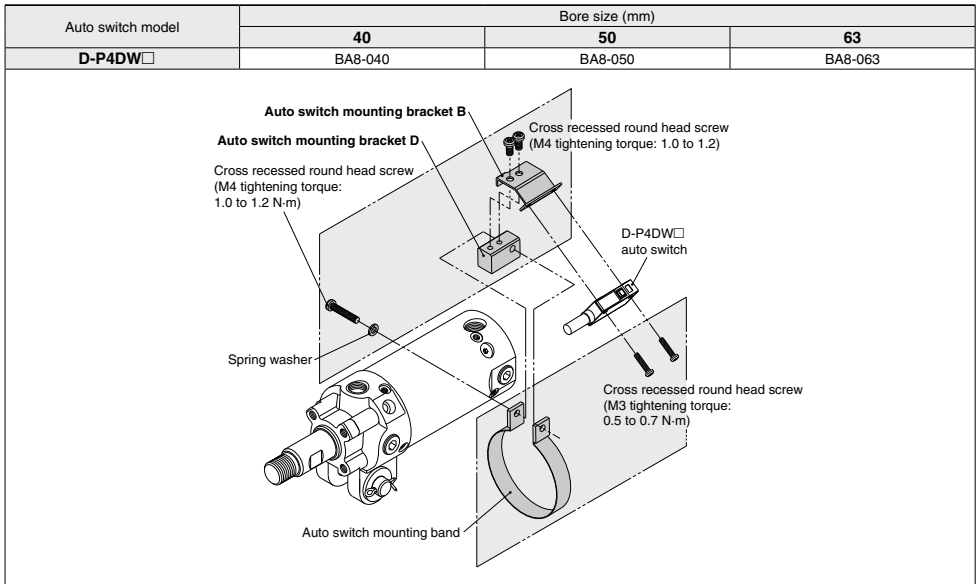

Auto switch model	Bore size (mm)		
	40	50	63
D-M9□ D-M9□W D-A9□	BMA3-040 <small>Note 1)</small> (A set of a, b, c, d)	BMA3-050 <small>Note 1)</small> (A set of a, b, c, d)	BMA3-063 <small>Note 1)</small> (A set of a, b, c, d)
D-M9□A <small>Note 2)</small>	BMA3-040S (A set of b, c, e, f)	BMA3-050S (A set of b, c, e, f)	BMA3-063S (A set of b, c, e, f)

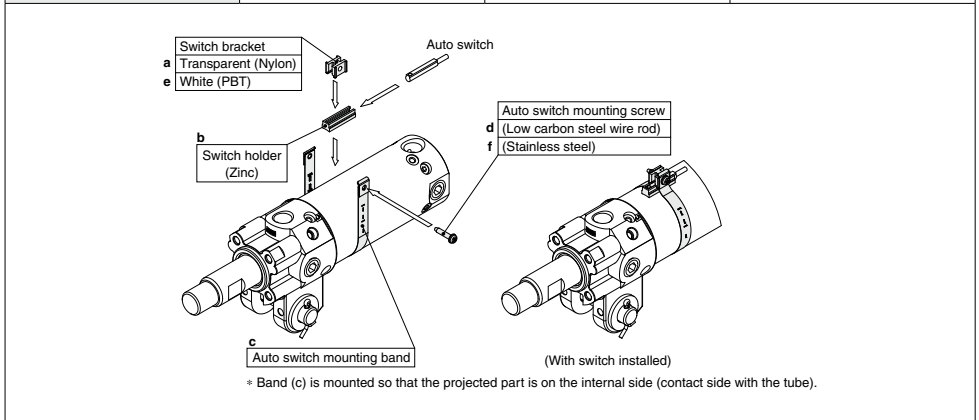

D-B54	BA-04 (A set of band and screw)	BA-05 (A set of band and screw)	BA-06 (A set of band and screw)
--------------	------------------------------------	------------------------------------	------------------------------------

Note 1) Since the switch bracket (made from nylon) are affected in an environment where alcohol, chloroform, methylamines, hydrochloric acid or sulfuric acid is splashed over, so it cannot be used. Please contact SMC regarding other chemicals.

Note 2) When mounting a D-M9□A(V) type auto switch, if the switch bracket is mounted on the indicator light, it may damage the auto switch. Therefore, be sure to avoid mounting the switch bracket on the indicator light.

CK□1 Series

Made to Order

Please contact SMC for detailed dimensions, specifications and lead times.



1 CK□1□40, 50, 63/With Air Cushion on Both Ends

Symbol

-X1515

Clamp cylinder with air cushion on both ends (with cushion in the clamped/unclamped side)

⚠ Caution

The air cushion is integrated in the unclamped side (head end) only for the standard type CK1/CKG1/CKP1 series, bore size 40, 50 and 63. When an air cushion is required on both ends, it is available as a made-to-order -X1515.

Basic type	CK1	Enter the standard model no.	-	X1515
Built-in standard magnet type with magnetic field resistant auto switch	CKG1	Enter the standard model no.	-	X1515
Built-in strong magnet type with magnetic field resistant auto switch	CKP1	Enter the standard model no.	-	X1515

With air cushion on both ends •

Dimensions: Same as standard type

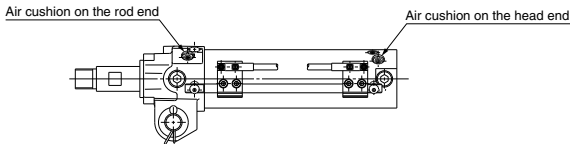

Specifications: Same as standard type

Specifications

Thread type	Rc1/4 only
Specifications other than above	Same as standard type



CK□1 Series

Specific Product Precautions 1

Be sure to read this before handling the products. Refer to page 9 for safety instructions and pages 10 to 19 for actuator and auto switch precautions.

Cushion/Speed Controller Adjustment

⚠ Danger

1. Retaining construction with crimping is integrated in the speed controller valve and cushion valve. However, do not rotate the cushion valve exceeding two turns, and do not rotate the speed controller valve exceeding four and half turns ($\phi 40$: maximum two turns). If 0.6 N·m or more of torque is applied, the valve may become loose and may jump out depending on the amount of air pressure.

Cushion Adjustment

The air cushion is built in on the head end for the CK1 series. The cushion is pre-adjusted at the time of shipping. However, re-adjust the cushion valve on the tube cover depending on the operating speed and load before use. When rotating the cushion valve clockwise, the orifice becomes smaller, resulting in stronger cushion reaction.

Speed Controller Adjustment

The speed controller (exhaust restrictor) is built in on the rod and head end for the CK1 series. The cushion is pre-adjusted at the time of shipping. However, re-adjust the speed controller valve ("S" marking on the rod cover) on each cover depending on the operating speed and load before use.

When rotating the speed controller valve clockwise, the orifice becomes smaller, which reduces the speed.

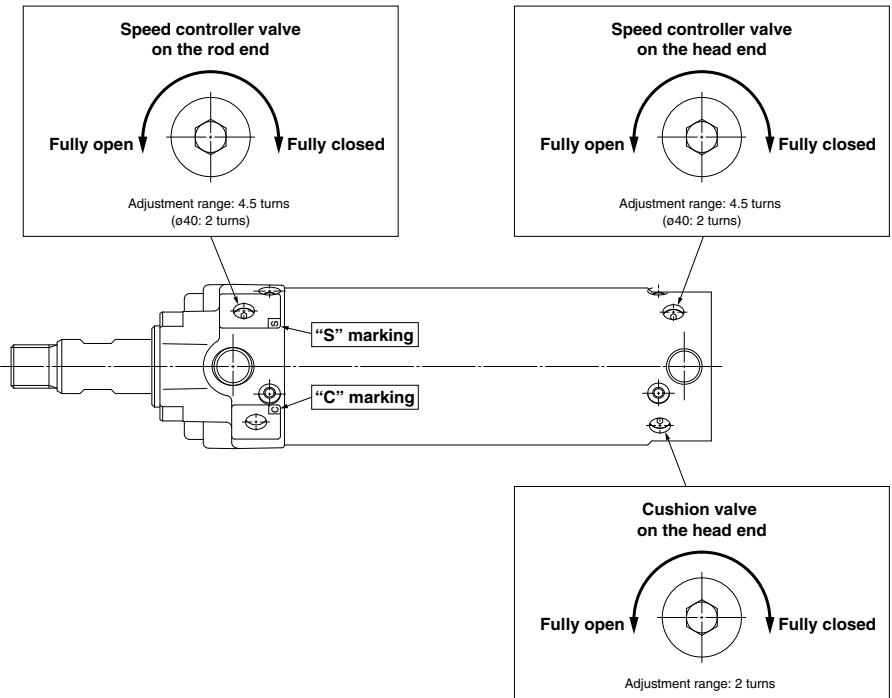



CK□1 Series

Specific Product Precautions 2

Be sure to read this before handling the products. Refer to page 9 for safety instructions and pages 10 to 19 for actuator and auto switch precautions.

Piping Port/Switch Mounting Rod Location Change

Piping Port Location Change

Piping is possible from 3 directions. When the piping port location is changed, carefully follow the instructions as detailed below.

⚠ Warning

1. Do not leave out the component parts when the piping port location is changed.

Even if one of the component parts is kept away, malfunction may occur, resulting in dangerous operation.

2. To prevent air leakage, re-wind the pipe tape and fit into the changed location when the piping port location is changed.

Switch Mounting Rod Location Change

The switch mounting rod is mountable from 3 directions. When the switch mounting rod is changed, carefully follow the instruction as detailed below.

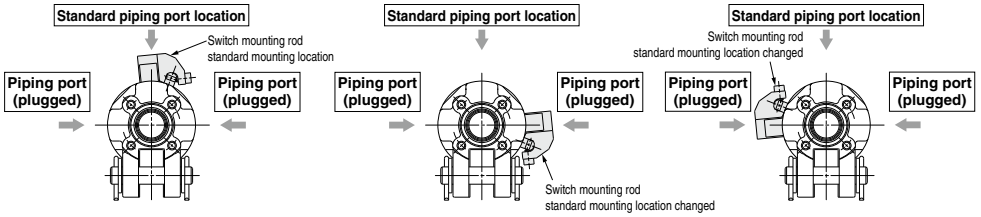

⚠ Warning

1. Mount all the component parts to the changed location.

Even if one of the component parts is kept away, the switch detection error etc. may occur. (Switch mounting rod, switch mounting spacer, hexagon socket head cap screw)

2. After the switch mounting rod location is changed, confirm that there is no interference with other parts before use.

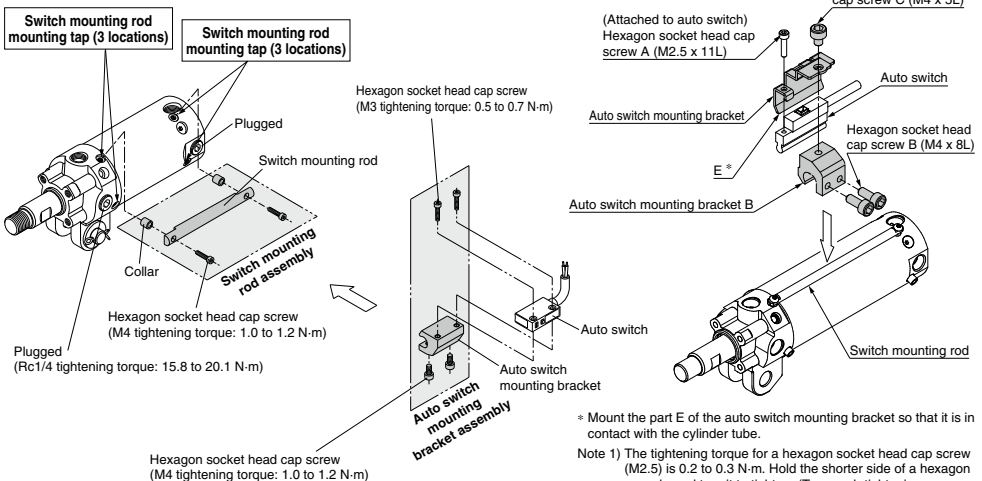

* Mount the part E of the auto switch mounting bracket so that it is in contact with the cylinder tube.

Note 1) The tightening torque for a hexagon socket head cap screw (M2.5) is 0.2 to 0.3 N·m. Hold the shorter side of a hexagon wrench, and turn it to tighten. (Too much tightening may break the switch)

Note 2) Tighten the hexagon socket head cap screws B and C (M4) with a tightening torque of 1 to 1.2 N·m.



CK□1 Series

Specific Product Precautions 3

Be sure to read this before handling the products. Refer to page 9 for safety instructions and pages 10 to 19 for actuator and auto switch precautions.

Handling

Magnetic field resistant auto switches D-P79WSE/D-P74□ are specifically for use with built-in strong magnet type cylinders and are not compatible with general auto switches or cylinders. Built-in strong magnet type cylinders are labeled as follows.

Magnetic field resistant cylinder with built-in magnet
(For use with auto switch D-P7)

Mounting

1. The minimum stroke for mounting magnetic field resistant auto switches is 50 mm.
2. In order to fully use the capacity of magnetic field resistant auto switches, strictly observe the following precautions.
 - 1) Do not allow the magnetic field to occur when the cylinder piston is moving.
 - 2) When a welding cable or welding gun electrodes are near the cylinder, change the auto switch position to fall within the operational ranges shown in the graphs on page 456, or move the welding cable away from the cylinder.
 - 3) Cannot be used in an environment where welding cables surround the cylinder.
 - 4) Please consult with SMC when a welding cable and welding gun electrodes (something energized with secondary current) are near multiple auto switches.
3. In an environment where spatter directly hits the lead wire, cover the lead wire with protective tubing.
Use protective tubing with inside diameter of $\phi 8$ or more that has excellent heat resistance and flexibility.
4. Be careful not to drop objects, make dents, or apply excessive impact force when handling.
5. When operating two or more cylinders with magnetic field resistant auto switches in parallel and proximity, separate the auto switches from other cylinder tubes by an additional 30 mm or more.
6. Avoid wiring in a manner in which repeated bending stress or tension is applied to lead wires.
7. Please consult with SMC regarding use in an environment with constant water and coolant splashing.
8. Be careful of the mounting direction of the magnetic field resistant auto switch D-P79WSE.
Be sure to face the soft-resin mold surface to the switch mounting bracket side for mounting.

(Refer to page 448 for mounting example and page 1430 for soft-resin mold surface.)

Wiring/Current and Voltage

1. Always connect the auto switch to the power supply after the load has been connected.
2. Series connection
When auto switches are connected in series as shown below:

Note that the voltage drop due to the internal resistance of the LED increases.





CK□1 Series

Specific Product Precautions 4

Be sure to read this before handling the products. Refer to page 9 for safety instructions and pages 10 to 19 for actuator and auto switch precautions.

Data: Magnetic Field Resistant Reed Auto Switches (D-P79WSE, D-P74□) Safety Distance

Safety Distance from Side of Auto Switch

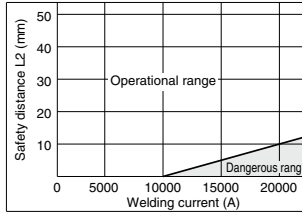
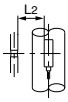
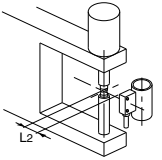
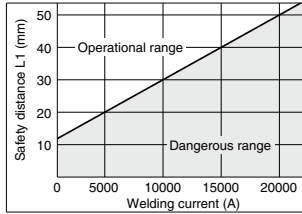
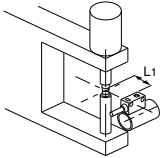

Safety Distance from Top of Auto Switch

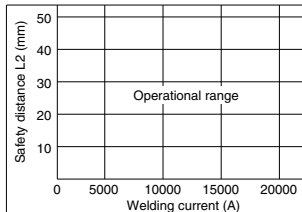
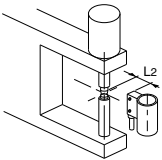
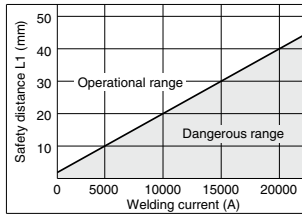
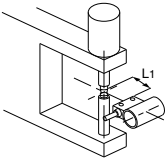

CK□1 Series

Related Products

Please contact SMC for detailed dimensions, specifications and lead times.

1 CKGA80, 100/CKPA80, 100/With Magnetic Field Resistant Auto Switch (Rod Mounting Type)

Built-in standard magnet type with magnetic field resistant auto switch

Built-in strong magnet type with magnetic field resistant auto switch

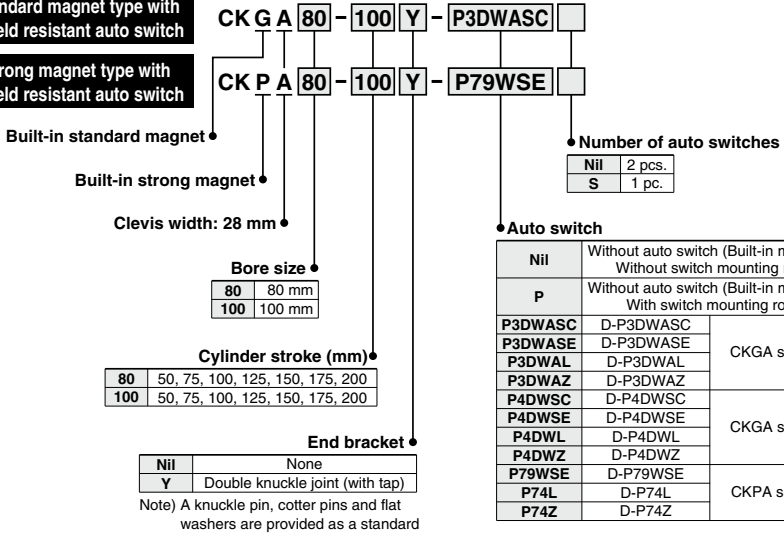

Specifications

Clevis width	28 mm	CKGA/CKPA series
Fluid	Air	
Proof pressure	1.5 MPa	
Maximum operating pressure	1.0 MPa	
Minimum operating pressure	0.05 MPa	
Ambient and fluid temperature	-10°C to 60°C	
Piston speed	50 to 500 mm/s	
Cushion	With air cushion on both ends	
Speed controller	Equipped on both ends	
Lubrication	Non-lube	
Stroke length tolerance	+ ₀ ^{1.0}	
Mounting <small>(Note)</small>	Double clevis	

Note) A clevis pin, cotter pins and flat washers are provided as a standard.

Auto Switch Mounting Bracket Assembly/Part No.

Applicable auto switch model	Auto switch mounting bracket part no.	
	80	100
D-P3DWASC	BK7-080S	
D-P3DWASE		
D-P3DWAL		
D-P3DWAZ		
D-P4DWSC	BK9-080	
D-P4DWSE		
D-P4DWL		
D-P4DWZ		
D-P79WSE	BK10-080	
D-P74L		
D-P74Z		

Built-in Standard (Strong) Magnet Cylinder Part No.

- 1) Built-in standard (strong) magnet type without auto switch, without switch mounting rod
Symbol for the auto switch type is "Nil" as shown below.
CKGA: (Example) CKGA80-50Y
CKPA: (Example) CKPA80-50Y
- 2) Built-in standard (strong) magnet type without auto switch, with switch mounting rod
Symbol for the auto switch type is "P" as shown below.
CKGA: (Example) CKGA80-50Y-P
CKPA: (Example) CKPA80-50Y-P

1 CKGA80, 100/CKPA80, 100/With Magnetic Field Resistant Auto Switch (Rod Mounting Type)

Dimensions

CKGA80 Built-in standard magnet type/with magnetic field resistant auto switch (D-P4DWS□)

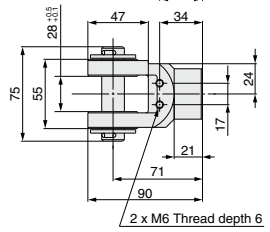
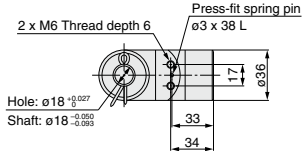
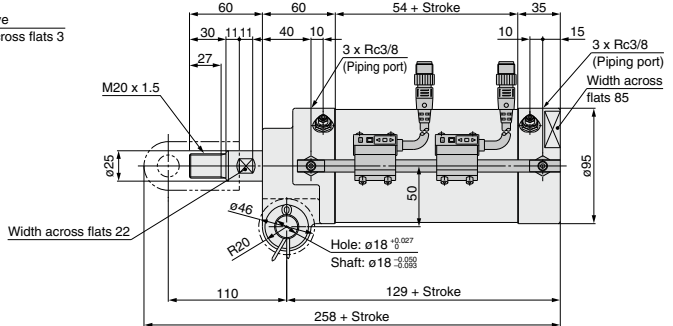
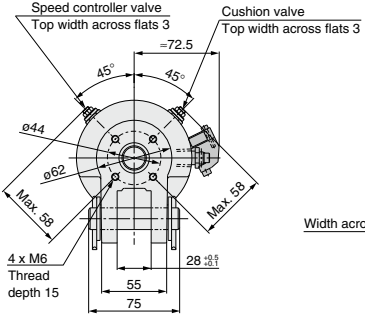

Double knuckle joint

CKPA80 Built-in strong magnet type/with magnetic field resistant auto switch (D-P79WSE)

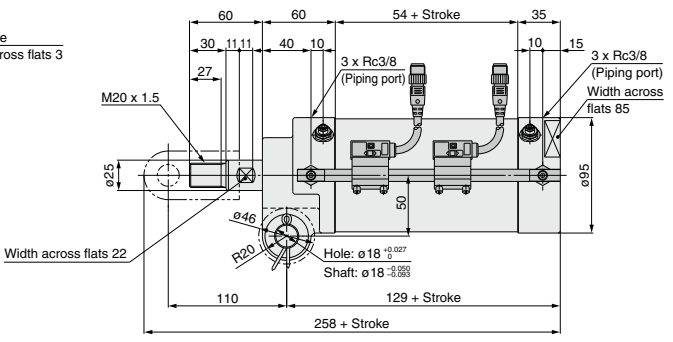
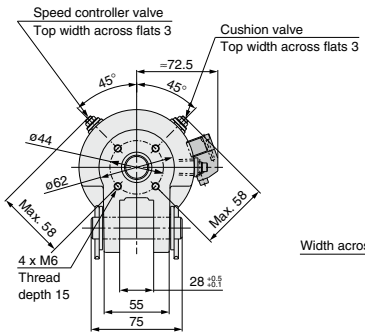

1 CKGA80, 100/CKPA80, 100/With Magnetic Field Resistant Auto Switch (Rod Mounting Type)

Dimensions

CKGA100 Built-in standard magnet type/with magnetic field resistant auto switch (D-P4DWS□)

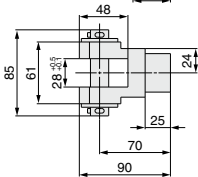
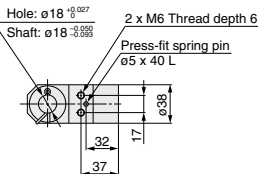
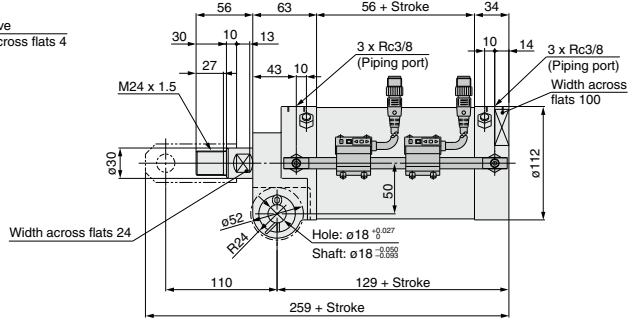
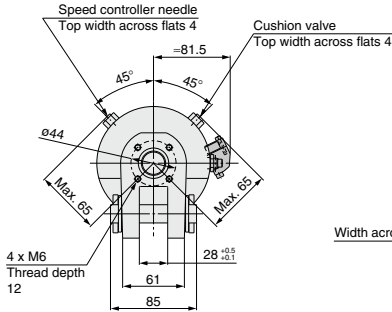

Double knuckle joint

CKPA100 Built-in strong magnet type/with magnetic field resistant auto switch (D-P79WSE)

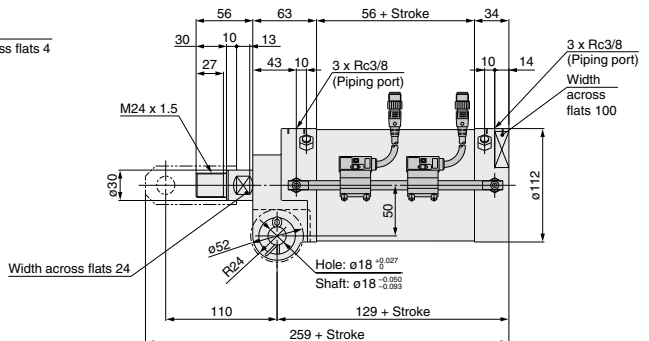
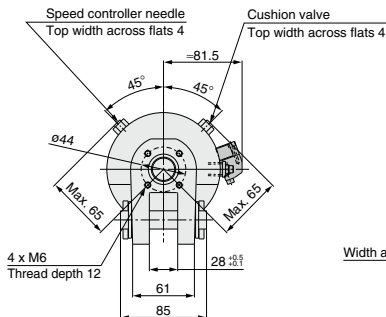

* Please contact SMC for details of the CKGA□/CKPA□ series.

2 CKGA32/With Magnetic Field Resistant Auto Switch D-P4DW□□ (Band Mounting Type)

Band mounting of the magnetic field resistant auto switch (D-P4DW□□) to the built-in standard magnet clamp cylinder (CKGA32 series) is possible by ordering the auto switch mounting bracket and the auto switch separately.

Built-in standard magnet type with magnetic field resistant auto switch

CKGA32 - 100 Y

- Built-in standard magnet
- Clevis width: 12 mm
- Bore size: 32 mm
- Cylinder stroke (mm)

50, 75, 100, 125, 150

- End bracket

Nil	None
I	Single knuckle joint (without tap)
Y	Double knuckle joint (without tap)

Note) A knuckle pin, cotter pins and flat washers are provided as a standard for Y.

Specifications

Clevis width	12 mm	CKGA32 series
Fluid	Air	
Proof pressure	1.5 MPa	
Maximum operating pressure	1.0 MPa	
Minimum operating pressure	0.05 MPa	
Ambient and fluid temperature	-10°C to 60°C	
Piston speed	50 to 500 mm/s	
Cushion	With air cushion on both ends	
Lubrication	Non-lube	
Stroke length tolerance	+1.0 0	
Mounting ^{Note)}	Double clevis	

Note) A clevis pin, cotter pins and flat washers are provided as a standard.

Applicable auto switch model	Auto switch mounting bracket part no.
D-P4DWSC	BA8-032
D-P4DWSE	
D-P4DWL	
D-P4DWZ	

Dimensions

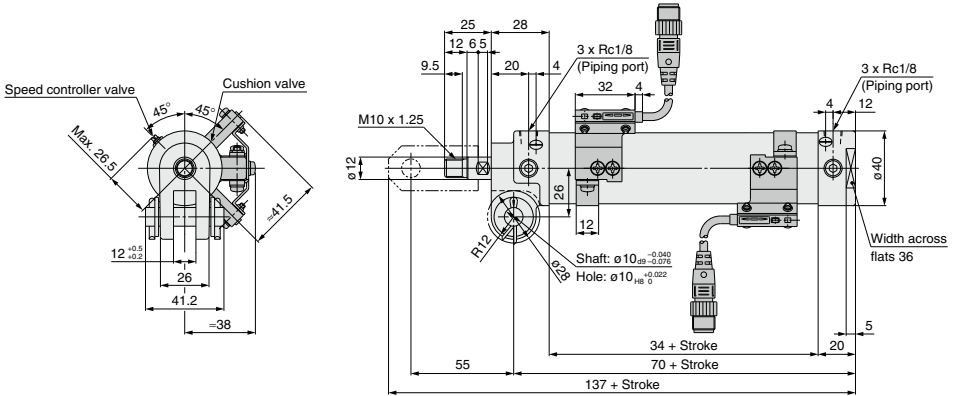

Single knuckle joint

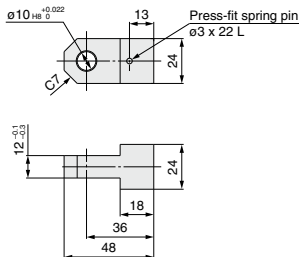

Double knuckle joint

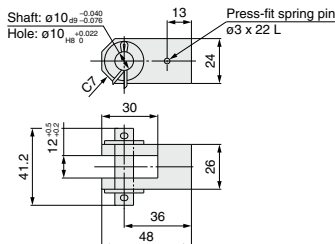

* Please contact SMC for details of the CKGA32 series.