

Stopper Cylinder

RSQ Series (Fixed mounting height)

RSG Series (Adjustable mounting height)

Ø12, Ø16, Ø20, Ø32, Ø40, Ø50 Ø40, Ø50

Realize labor saving and automation of conveyor line

A through-hole type and a both ends tapped type are available.
RSQ series (Fixed mounting height type)
 Ø12, Ø16, Ø20, Ø32, Ø40, Ø50

Mounting position can be adjusted arbitrarily by changing the attached flange height.
RSG series (Adjustable mounting height type)
 Ø40, Ø50

Numerous variations

It is possible to select option for many applications.
 Type: Fixed mounting height (RSQ), Adjustable mounting height (RSG)
 Action: Double acting, Single acting (Spring extend), Double acting with spring
 Rod end configuration: Round bar type, Chamfered type, Roller type, Lever type
 Mounting: Through-hole, Both ends tapped (RSQ)
 Flange: (RSG)

Equipped with an easy-to-maintain shock absorber.

The shock absorber incorporated in the lever type is adjustment-free and easy-to-maintain. (Ø32, Ø40, Ø50)

Auto switch option available

Compact auto switch mounting to enable miniaturization of machines and designs.

Lever type selected according to applications

- Prevention of repulsion by light pallets...Locking mechanism
- Partial passing of work.....With cancel



Lock Mechanism

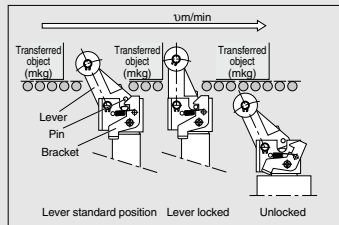

Cancel Cap (Mechanism to hold lever horizontally)

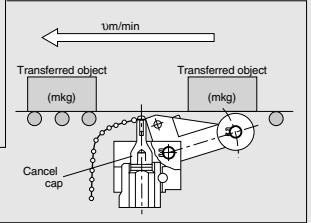

RSQ

RSG

RS2H

RSH

MIW

MIS

Series Variations

Series	Mounting	Action	Rod end configuration	Standard variations				Bore size (mm)	Standard stroke (mm)							
				Built-in magnet	With lock mechanism	With cancel	Built-in One-touch fittings		10	15	20	25	30			
RSQ	Through-hole	Double acting	Round bar type	•	•	•	•	12	•							
			Roller type	•	•	•	•									
	Both ends tapped type	Double acting with spring loaded	Chamfered type	•	•	•	•		16	•	•					
			Lever type	Fixed	•	•	•			•						
				Adjustable	•	•	•			•						
Flange type	Double acting	Double acting with spring loaded	Round bar type	•	•	•	•	20		•	•	•				
			Roller type	•	•	•	•									
RSG	Flange type	Single acting	Chamfered type	•	•	•	•		32	•	•	•				
			Lever type	Fixed	•	•	•			•	40	•	•	•	•	
				Adjustable	•	•	•			•						
			Spring extend	Spring extend	Round bar type	•	•	•		•		40	•	•	•	•
					Roller type	•	•	•		•						
Flange type	Roller type	•	•	•	•	50	•	•	•	•						
Spring extend	Spring extend	Chamfered type	•	•	•		•	50	•	•	•		•			
		Lever type	Fixed	•	•		•		•							
Adjustable	Adjustable	•	•	•	•											

D-□

-X□

Stopper Cylinder/Fixed Mounting Height

RSQ Series

ø12, ø16, ø20, ø32, ø40, ø50

The RSQ series (standard type, ø16 to ø50) has been remodeled. When selecting a product, please consider using the new RSQ series.

How to Order

Standard RSQ **B** 20 - 15 **D** -

With auto switch RSDQ **B** 20 - 15 **D** - **M9BW** -

Mounting bracket

- B** Through-hole (Standard)
- A** Both ends tapped type

Note 1) Since ø12 uses a common tube for both A and B, only B is used for part no. denotation.

With auto switch
(Built-in magnet)

Port thread type

Nil	M thread	ø12, ø16
	Rc	
	TN	ø20 to ø50
	NPT	
TF	G	
F	Built-in One-touch fittings (2)	

Note 2) Bore sizes available w/ One-touch fittings are ø20 to ø50.
Note 3) TF for ø20 indicates M5.

Auto switch

- Nil Without auto switch

* For the applicable auto switch model, refer to the table below.

Made to Order Specifications
For details, refer to page 561.

Number of auto switches

Nil	2 pcs.
S	1 pc.

Rod end configuration

Symbol	Configuration	Application
Nil	Rounded bar type	—
K	Chamfered type	—
R	Roller type	—
L	Lever type (Non-adjustable) (4)	Basic type
B	Lever type (4) (Energy absorbing Adjustable deformation)	—
C		With cancel cap
D		With lock mechanism
E		With lock & cancel

Note 4) The lever types are applicable only to bore sizes ø32, ø40 and ø50.

Cylinder stroke (mm)

12	10
16	10, 15
20	10, 15, 20
32	10, 15, 20
40	20, 25, 30
50	20, 25, 30

Built-in Magnet Cylinder Model

If a built-in magnet cylinder without an auto switch is required, there is no need to enter the symbol for the auto switch.
(Example) RSDQB32-15D

Action

D	Double acting
B	Double acting with spring loaded
T	Single acting (Spring extend)

Applicable Auto Switches

Refer to pages 941 to 1067 for further information on auto switches.

Type	Special function	Electrical entry	Incision/light	Wiring (Output)	Load voltage		Auto switch model				Lead wire length (m)					Pre-wired connector	Applicable load					
					DC	AC	Perpendicular ø12 ø16, ø20, ø32 to ø50	In-line ø12 ø16, ø20, ø32 to ø50	0.5 (Nil)	1 (M)	3 (L)	5 (Z)	None (N)									
														24 V	5 V, 12 V			5 V, 12 V	5 V, 12 V	5 V, 12 V	5 V, 12 V	5 V, 12 V
Solid state auto switch	—	Grommet	Incision	3-wire (NPN)	5 V,	—	—	M9NV	M9N	●	●	○	—	—	IC circuit	Relay, PLC						
				3-wire (PNP)	12 V					●	●	○	—	○								
		Connector	2-wire	12 V	—					—	●	●	●	●			—	—				
			3-wire (NPN)	5 V,	24 V					—	M9NWV	M9NW	●	●			○	—	○			
		3-wire (PNP)	12 V	●									●	○			—	○				
		Grommet	2-wire	12 V									—	—			●	●	○	—	○	
	3-wire (NPN)		5 V,	24 V		—	M9PWV	M9PW	●				●	○	—		○					
	3-wire (PNP)	12 V	●						●				○	—	○							
	Water resistant (2-color indicator)	2-wire	12 V						—				—	●	●		○	—	○			
		3-wire (NPN)	5 V,		24 V				—	M9BWW	M9BW	●	●	○	—		○					
	3-wire (PNP)	12 V	●									●	○	—	○							
	With diagnostic output (2-color indicator)	2-wire	12 V									—	—	○	○		○	○	—	○		
4-wire		5 V, 12 V	—	—		○	○	○				○	—	○								
Magnetic field resistant (2-color display)	2-wire (Non-polar)	—	—	—		—	—	—				—	—	—	○							
	—	—	—	—		—	—	—				—	—	—	○							
Reed auto switch	—	Grommet	Yes	3-wire (NPN equivalent)	5V	—	—	A96V	A96	●	—	●	—	—	IC circuit	Relay, PLC						
				—	200 V					—	A72	—	A72H	●			—	●	—			
		Connector	No/Yes/No	2-wire	12 V					100 V	A93V ^{*2}	A93	●	●			●	●	—	—		
				5 V, 12 V	100 V or less					A90V	A90	●	●	●			●	—	—			
		Grommet	Yes	2-wire	12 V					—	A73C	—	—	—			—	●	●	●	●	—
				5 V, 12 V	24 V or less					A80C	—	—	—	—			—	—	●	●	●	●
	Diagnostic indication (2-color indicator)	No/Yes/No	2-wire	—	—	A79W	—	—	—	—	●	—	●	—	—							
			—	—	—	—	—	—	—	—	—	●	—	●	—							

*1 Water resistant type auto switches can be mounted on the above models, but in such case SMC cannot guarantee water resistance. Consult with SMC regarding water resistant types with the above model numbers.

*2 1 m type lead wire is only applicable to D-A93.

* Lead wire length symbols: 0.5 m Nil (Example) M9NW
1 m M (Example) M9NWW
3 m L (Example) M9NWL
5 m Z (Example) M9NWZ
None N (Example) J79CN

** Solid state auto switches marked with "○" are produced upon receipt of order.
** The D-P3DWA□ is mountable on bore size ø32 to ø50.

* Since there are other applicable auto switches than listed, refer to page 574 for details.
* For details about auto switches with pre-wired connector, refer to pages 1014 and 1015.
* When D-AS□(V)/M9□(V)/M9□W(V)/M9□A(V) types with ø32 to ø50 are mounted on a side other than the port side, order auto switch mounting brackets separately. Refer to page 574 for details.

Stopper Cylinder/Fixed Mounting Height **RSQ Series**

Model



Lever type with built-in shock absorber

Roller type

Round bar



Made to Order Specifications
[Click here for details](#)

Symbol	Specifications
-XA□	Change of rod end shape
-XC3	Special port location

Spring Force (Single acting)

Bore size (mm)	(N)	
	Extended	Compressed
12	3.9	9.6
16	4.9	14.9
20	3.4	14.9
32	8.8	18.6
40, 50	13.7	27.5

* Applicable only to round bar type, chamfered type and roller type end configurations.

Bore size (mm)		12	16	20	32	40	50
Mounting	Through-hole	● ^{Note1)}	●	●	●	●	●
	Both ends tapped type		●	●	●	●	●
Built-in magnet		●	●	●	●	●	●
Piping	Screw-in type	M5 x 0.8		1/8 ^{Note2)}			
	Built-in One-touch fittings	—		ø6/4		ø8/6	
Action		Double acting, Single acting (Spring extend), Double acting with spring loaded					
Rod end configuration	Round bar	●		●			
	Chamfered	●		●			
	Roller type	●		●			
	Lever type	—		●			

Note 1) ø12 tubes can have both through-hole and tap mountings in the same tube.

Note 2) TF (G thread) for ø20 indicates M5 x 0.8.

Specifications

Action	Double acting, Double acting with spring loaded, Single acting (Spring extend)
Fluid	Air
Proof pressure	1.5 MPa
Maximum operating pressure	1.0 MPa
Ambient and fluid temperature	Without auto switch: -10 to 70°C * With auto switch: -10 to 60°C (No freezing)
Lubrication	Not required (Non-lube)
Cushion	Rubber bumper
Stroke length tolerance	+1.4 ^{Note 1)} 0
Piston speed	50 to 500 mm/s
Mounting	Through-hole/Both ends tapped
Auto switch	Mountable

Note 1) Stroke length tolerance does not include the amount of bumper change.

Bore Size/Standard Stroke

Bore size (mm)	Rod end configuration (mm)	
	Round bar, Chamfered type, Roller type	Lever type with shock absorber
12	10	—
16	10, 15	—
20	10, 15, 20	—
32		10, 15, 20
40	20, 25, 30	20, 25, 30
50		20, 25, 30

Weight

Action	Bore size (mm)	Rod end configuration	Cylinder stroke (mm)				
			10	15	20	25	30
Double acting	12	Round bar, Chamfered, Roller	0.07	—	—	—	—
	16	Round bar, Chamfered, Roller	0.14	0.15	—	—	—
	20	Round bar, Chamfered, Roller	0.23	0.24	0.25	—	—
Single acting, Spring extend	32	Round bar, Chamfered, Roller	0.42	0.44	0.46	—	—
		Lever with built-in shock absorber	0.51	0.53	0.55	—	—
Double acting with spring loaded	40	Round bar, Chamfered, Roller	—	—	0.74	0.80	0.86
		Lever with built-in shock absorber	—	—	0.97	1.01	1.05
	50	Round bar, Chamfered, Roller	—	—	1.03	1.07	1.11
		Lever with built-in shock absorber	—	—	1.26	1.30	1.34

RSQ

RSQ

RS2H

RSH

MIW

MIS

D-□

-X□

RSQ Series

Mounting Bolt for RSQB

Mounting method: Mounting bolt for through-hole mounting type of RSQB is available as an option.
Refer to the following for ordering procedures.
Order the actual number of bolts that will be used.

Example) CQ-M3x45L 2 pcs.

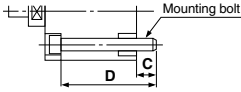

Cylinder model	C	D	Mounting bolt part no.
RSQB12-10□ ^(Note)	5	45	CQ-M3 x 45L
RSQB16-10□	7.5	60	CQ-M3 x 55L
-15□		x 60L	
RSQB20-10□	7	55	CQ-M5 x 55L
-15□		60	x 60L
-20□		65	x 65L
RSQB32-10□	9	60	CQ-M5 x 60L
-15□		65	x 65L
-20□		70	x 70L

(mm)			
Cylinder model	C	D	Mounting bolt part no.
RSQB40-20□	9.5	75	CQ-M5 x 75L
-25□		80	CQ-M5 x 80L
-30□		85	x 85L
RSQB50-20□	9	75	CQ-M6 x 75L
-25□		80	x 80L
-30□		85	x 85L

(Note) Be sure to use the attached flat washers when mounting $\phi 12$ cylinders with through-holes.

Operating Ranges by Rod End Configuration

(Example 1) For roller type with transfer speed of 15 m/min. and the weight of transferred object of 30 kg.

(Example 2) Transfer speed of 15 m/min., Weight of transferred object of 60 kg, Friction coefficient $\mu = 0.1$, Lever type (Lever type with lock mechanism)

<How to read the graphs>

To select a cylinder based on the specifications above, find the intersection of the speed of 15 m/min. on the horizontal axis and the weight of 30 kg on the vertical axis in graph (1) below, and select RSQ□40-□□R that falls in the cylinder operating range.

<How to read the graphs>

To select a cylinder based on the specifications above, find the intersection of the speed of 15 m/min. on the horizontal axis and the weight of 60 kg on the vertical axis in graph (3) below, and select RSQ□40-□□D that falls in the cylinder operating range.

Roller Type/Round Bar Type/Chamfered Type

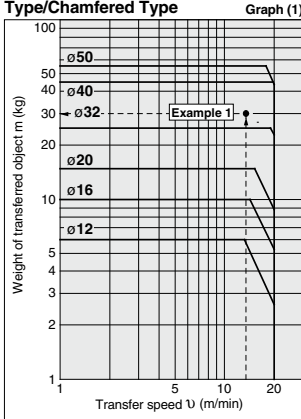

Lever Type (With shock absorber)

Friction coefficient $\mu = 0$

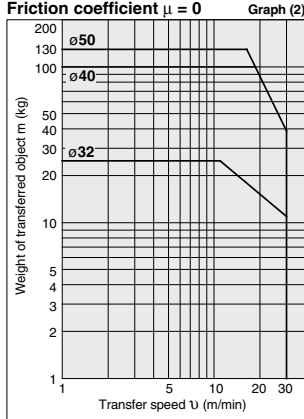

Lever Type (With shock absorber)

Friction coefficient $\mu = 0.1$

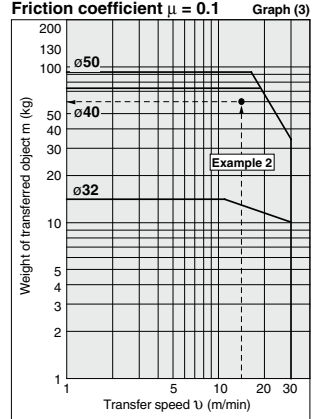

* Lever-type weight of transferred object and transfer speed graphs (graphs (2) and (3)) show the values at room temperature (20 to 25°C).

* When selecting cylinders, confirm the Specific Product Precautions as well.

Lateral Load and Operating Pressure

The larger the lateral load, the higher the operating pressure required for the stopper cylinder. Set the operating pressure using the graphs shown on the right as a guide. (Applicable for round bar, roller and chamfered type rod end configurations.)

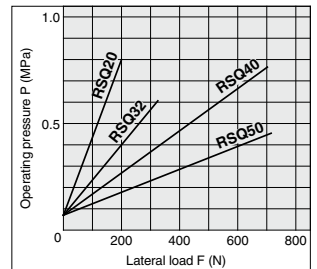
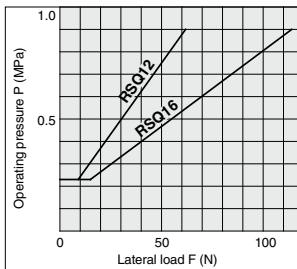

RSQ
RSG
RS2H
RSH
MIW
MIS

D-□
-X□

RSQ Series

Construction

Double acting

Roller rod end

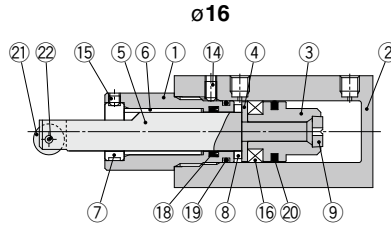
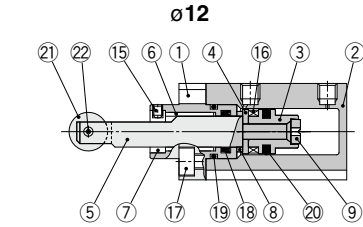

Round bar rod end type (D)

Chamfered rod end type (K)

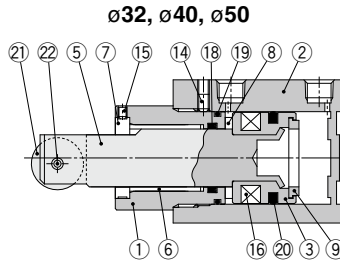
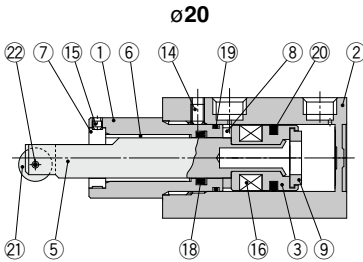

Double acting with spring loaded ø12, ø16

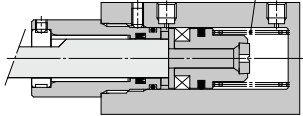

Single acting ø12, ø16

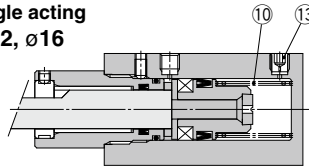

ø32, ø40, ø50

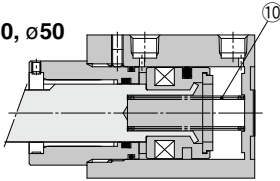

ø32, ø40, ø50

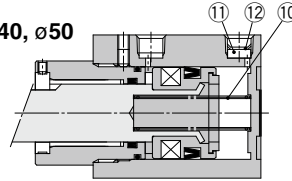

Component Parts

No.	Description	Material	Note
1	Rod cover	Aluminum alloy	Anodized
2	Cylinder tube	Aluminum alloy	Hard anodized
3	Piston	Aluminum alloy	
4	Spacer for switch	Aluminum alloy	ø12, ø16 only
5	Piston rod	ø12, ø16, ø20: Stainless steel ø32, ø40, ø50: Carbon steel	Hard chrome plated
6	Bushing	Bearing alloy	
7	Non-rotating guide	Rolled steel	Non-rotating type only
8	Bumper A	Urethane	
9	Bumper B	Urethane	
10	Return spring	Steel wire	Zinc chromated (Except double acting)
11	Element	Sintered metallic BC	ø20 to ø50 (Single acting only)

No.	Description	Material	Note
12	Retaining ring	Carbon tool steel	ø20 to ø50 (Single acting only)
13	Plug with fixed orifice	Alloy steel	ø12, ø16 only (Single acting only)
14	Hexagon socket head set screw	Chromium molybdenum steel	Except ø12
15	Hexagon socket head set screw	Chromium molybdenum steel	Non-rotating type only
16	Magnet	—	
17	Hexagon socket head cap screw	Alloy steel	ø12 only
18	Rod seal	NBR	
19	Gasket	NBR	
20	Piston seal	NBR	
21	Roller A	Resin	
22	Spring pin	Carbon tool steel	

Built-in shock absorber Lever rod end type (Fixed) ($\phi 32$, $\phi 40$, $\phi 50$ only)

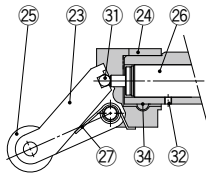
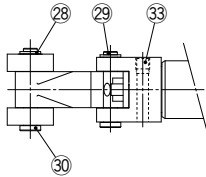

Only one roller is provided
for $\phi 32$.

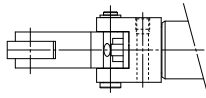

Lever rod end type (With lock mechanism and cancel cap) ($\phi 32$, $\phi 40$, $\phi 50$ only)

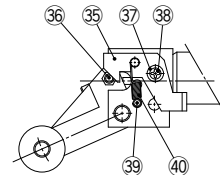
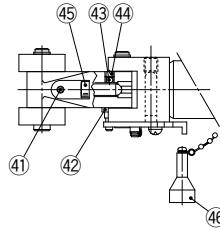

Component Parts

No.	Description	Material	Note
23	Lever	Cast iron	
24	Lever holder	Rolled steel	
25	Roller B	Resin	
26	Shock absorber	—	$\phi 32$ -RB1007-X225 $\phi 40, 50$ -RB1407-X552
27	Lever spring	Stainless steel wire	
28	Type C retaining ring for axis	Carbon tool steel	
29	Lever pin	Carbon steel	
30	Roller pin	Carbon steel	
31	Steel balls	High carbon chrome bearing steel	
32	Hexagon socket head set screw	Chromium molybdenum steel	
33	Hexagon socket head set screw	Chromium molybdenum steel	
34	One-side tapered pin	Carbon steel	

No.	Description	Material	Note
35	Bracket	Carbon steel	
36	Pin B	Carbon steel	
37	Spacer	Carbon steel	
38	Round head Phillips screw	Rolled steel	
39	Pin A	Rolled steel	
40	Bracket spring	Steel wire	
41	Hexagon socket head set screw	Chromium molybdenum steel	
42	Spring washer	Steel wire	
43	Urethane ball	Urethane	
44	Hexagon socket head set screw	Chromium molybdenum steel	
45	Adjustment bolt	Bearing steel	
46	Cancel cap	Aluminum alloy	

Replacement Parts/Seal Kit

Bore size (mm)	Kit no.			Contents
	Double acting	Double acting with spring loaded	Single acting	
12	RSQ12D-PS	RSQ12T-PS	RSQ12T-PS	Set of above nos. $\textcircled{18}$, $\textcircled{19}$, $\textcircled{20}$
16	RSQ16D-PS	RSQ16B-PS	RSQ16T-PS	
20	RSQ20D-PS	RSQ20B-PS	RSQ20T-PS	
32	RSQ32D-PS	RSQ32B-PS	RSQ32T-PS	
40	RSQ40D-PS	RSQ40B-PS	RSQ40T-PS	
50	RSQ50D-PS	RSQ50B-PS	RSQ50T-PS	

* Seal kit includes $\textcircled{18}$, $\textcircled{19}$, $\textcircled{20}$. Order the seal kit, based on each bore size.

* Since the seal kit does not include a grease pack, order it separately.

Grease pack part no.: GR-S-010 (10 g)

Replacement Parts: Shock Absorber

Bore size (mm)	Kit no.
32	RB1007-X225
40, 50	RB1407-X552

RSQ

RSQ

RSQH

RSH

MIW
MIS

D-□

-X□

RSQ Series

Rod End Configuration: Round Bar Type

Basic type: Through-hole mounting, Screw mounting

These 5 figures show the piston rod extended.

Bore size: $\phi 12$ RS□QB12-10□

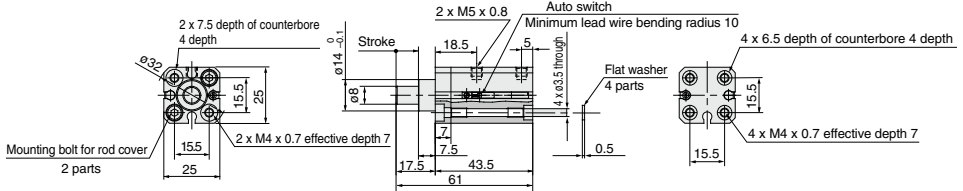

Bore size: $\phi 16, \phi 20$ RS□QB¹⁶₂₀-□□

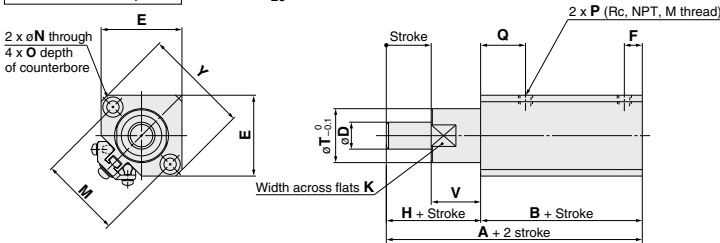

Bore size: $\phi 32, \phi 40, \phi 50$ RS□QB³²₄₀₅₀-□□

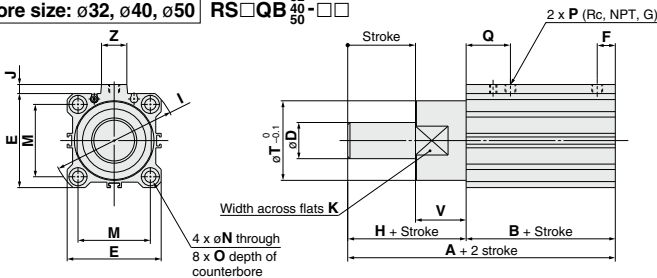

Built-in One-touch fittings ($\phi 20$ to $\phi 50$)

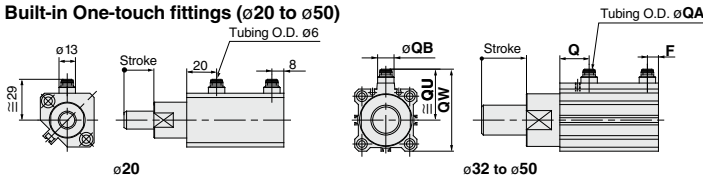

Built-in One-touch Fittings (mm)

Bore size (mm)	Applicable tubing O.D. QA	F	Q	QB	QU	QW
32	6	7.5	20	13	38	60.5
40	6	8	24.5	13	42	68
50	8	9.5	26	16	50	82

Bore size (mm)	A	B	D	E	F	H	I	J	K	M	N	O	P	Q	T	V	Y	Z
16	59.5	41.5	10	29	6	18	—	—	18	28	3.5	6.5 depth 4	M5 x 0.8	17	20	18	38	—
20	67	45	12	36	8	22	—	—	22	36	5.5	9 depth 7	1/8	20	24	22	47	—
32	68	48	20	45	7.5	20	60	4.5	32	34	5.5	9 depth 7	1/8	20	36	20	—	14
40	80.5	52.5	25	52	8	28	69	5	41	40	5.5	9 depth 7	1/8	24.5	44	28	—	14
50	82	54	25	64	8	28	86	7	50	50	6.6	11 depth 8	1/8	24.5	56	28	—	19

Note 1) M thread (M5 x 0.8) is applicable for $\phi 12$ and $\phi 16$ piping types.

TF (G thread) for $\phi 20$ also indicates M5 x 0.8.

Note 2) For the auto switch mounting position and its mounting height, refer to page 572.

Note 3) These figures show the piston rod extended.

Note 4) In the case of single acting type, a One-touch fitting is on the rod side only.

Note 5) The position of the width across flats K is arbitrary and is not specified.

Rod End Configuration: Chamfered (Non-rotating piston rod)

Basic type: Through-hole mounting, Screw mounting

These 5 figures show the piston rod extended.

Bore size: $\phi 12$ RS□QB12-10□K

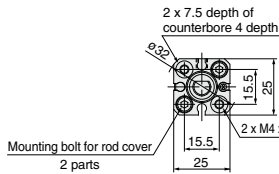

Bore size: $\phi 16, \phi 20$ RS□QB¹⁶/₂₀-□□K

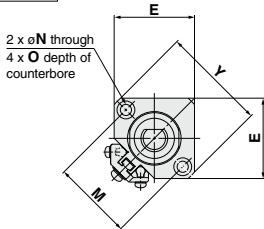

Bore size: $\phi 32, \phi 40, \phi 50$ RS□QB³²/₄₀/₅₀-□□K

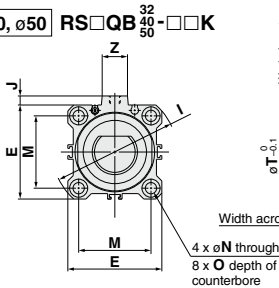

Built-in One-touch fittings ($\phi 20$ to $\phi 50$)

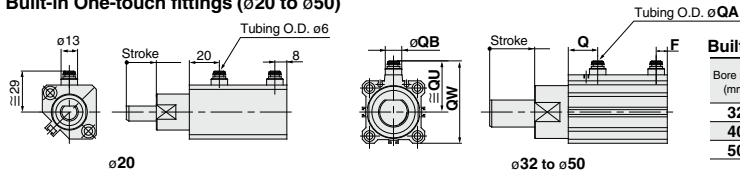

Built-in One-touch Fittings (mm)

Bore size (mm)	Applicable tubing O.D. QA	F	Q	QB	QU	QW
32	6	7.5	20	13	38	60.5
40	6	8	24.5	13	42	68
50	8	9.5	26	16	50	82

Bore size (mm)	A	B	D	E	F	G	H	I	J	K	M	N	O	P	Q	T	V	Y	Z
16	59.5	41.5	10	29	6	3	18	—	—	18	28	3.5	6.5 depth 4	M5 x 0.8	17	20	18	38	—
20	67	45	12	36	8	4	22	—	—	22	36	5.5	9 depth 7	1/8	20	24	22	47	—
32	68	48	20	45	7.5	8	20	60	4.5	32	34	5.5	9 depth 7	1/8	20	36	20	—	14
40	80.5	52.5	25	52	8	10	28	69	5	41	40	5.5	9 depth 7	1/8	24.5	44	28	—	14
50	82	54	25	64	8	10	28	86	7	50	50	6.6	11 depth 8	1/8	24.5	56	28	—	19

Note 1) M thread (M5 x 0.8) is applicable for $\phi 12$ and $\phi 16$ piping ports.
TF (G thread) for $\phi 20$ also indicates M5 x 0.8.

Note 2) For the auto switch mounting position and its mounting height, refer to page 572.

Screw mounting type: Both ends tapped type
RS□QA

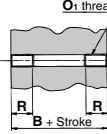

Model	B	O ₁	R
RS□QA16	41.5	M4 x 0.7	7
RS□QA20	45	M6 x 1	10
RS□QA32	48	M6 x 1	10
RS□QA40	52.5	M6 x 1	10
RS□QA50	54	M8 x 1.25	14

* Dimensions other than above are the same as below drawings.

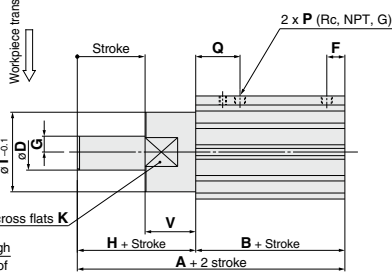
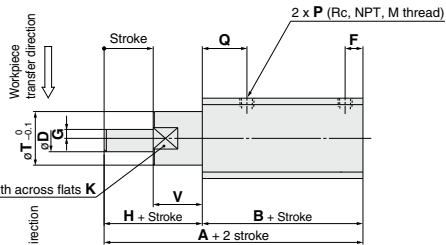
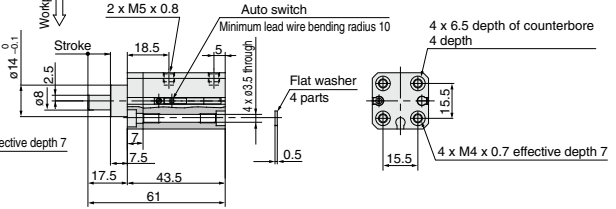

RSQ

RSQ

RS2H

RSH

MIW
MIS

D-□

-X□

RSQ Series

Rod End Configuration: Roller Type

Basic type: Through-hole mounting, Screw mounting

These 5 figures show the piston rod extended.

Bore size: $\phi 12$ RS□QB12-10□R

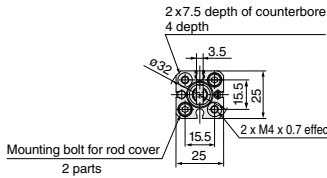

Bore size: $\phi 16, \phi 20$ RS□QB¹⁶/₂₀□□R

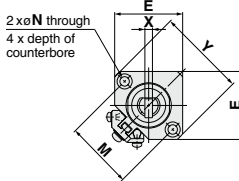

Bore size: $\phi 32, \phi 40, \phi 50$ RS□QB³²/₄₀/₅₀□□R

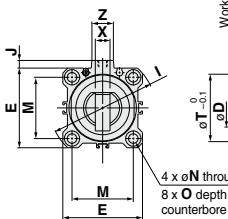

Screw mounting type: Both ends tapped type

RS□QA

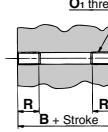

Model	B	O ₁	R
RS□QA16	41.5	M4 x 0.7	7
RS□QA20	45	M6 x 1	10
RS□QA32	48	M6 x 1	10
RS□QA40	52.5	M6 x 1	10
RS□QA50	54	M8 x 1.25	14

* Dimensions other than above are the same as below drawings.

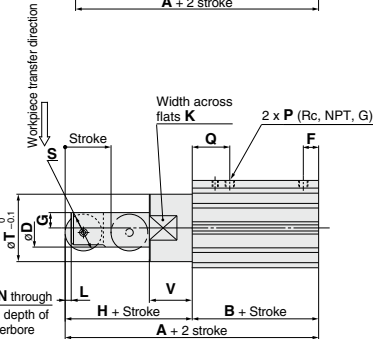
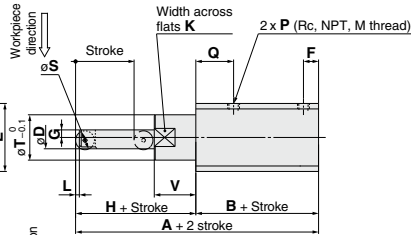
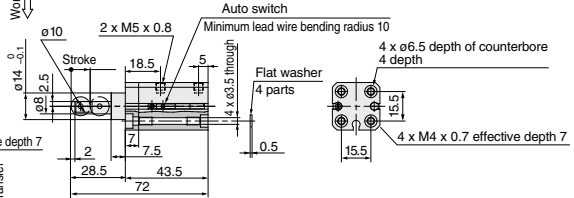

Built-in One-touch fittings ($\phi 20$ to $\phi 50$)

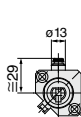

$\phi 20$

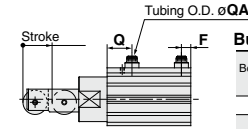
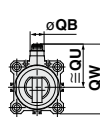
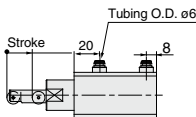

$\phi 32$ to $\phi 50$

Built-in One-touch Fittings (mm)

Bore size (mm)	Applicable tubing O.D. QA	F	Q	QB	QU	QW
32	6	7.5	20	13	38	60.5
40	6	8	24.5	13	42	68
50	8	9.5	26	16	50	82

Bore size (mm)	A	B	D	E	F	G	H	I	J	K	L	M	N	O	P	Q	S	T	V	X	Y	Z
16	68	41.5	10	29	6	3	26.5	—	—	18	2	28	3.5	6.5 depth 4	M5 x 0.8	17	8	20	18	3.5	38	—
20	78	45	12	36	8	4	33	—	—	22	2	36	5.5	9 depth 7	1/8	20	10	24	22	4	47	—
32	87	48	20	45	7.5	8	39	60	4.5	32	3	34	5.5	9 depth 7	1/8	20	18	36	20	8	—	14
40	105.5	52.5	25	52	8	10	53	69	5	41	4	40	5.5	9 depth 7	1/8	24.5	24	44	28	9	—	14
50	107	54	25	64	8	10	53	86	7	50	4	50	6.6	11 depth 8	1/8	24.5	24	56	28	9	—	19

Note 1) M thread (M5 x 0.8) is applicable for $\phi 12$ and $\phi 16$ piping ports.

TF (G thread) for $\phi 20$ also indicates M5 x 0.8.

Note 2) For the auto switch mounting position and its mounting height, refer to page 572.

Note 3) These figures show the piston rod extended.

Note 4) In the case of single acting type, a One-touch fitting is on the rod side only.

Note 5) The position of the width across flats K is arbitrary and is not specified.

Rod End Configuration: Lever Type with Shock Absorber

Basic type: Through-hole mounting, Screw mounting

These 3 figures show the piston rod extended.

Bore size: $\phi 32$ RS□QB32-□□L

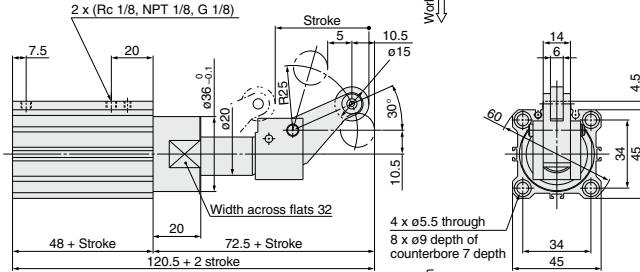

Screw mounting type: Both ends tapped type (mm)

RS□QA

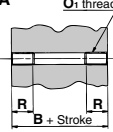

Model	B	O ₁	R
RS□QA32	48	M6 x 1	10
RS□QA40	52.5	M6 x 1	10
RS□QA50	54	M8 x 1.25	14

* Dimensions other than above are the same as below drawings.

Bore size: $\phi 40, \phi 50$ RS□QB⁴⁰/₅₀-□□L

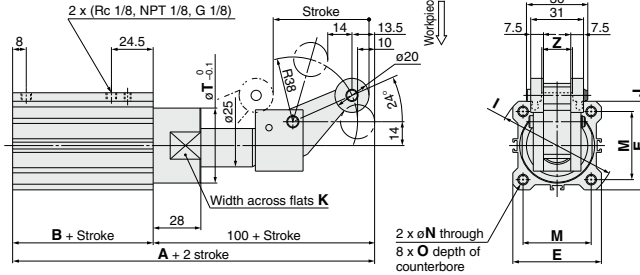

Built-in One-touch fittings

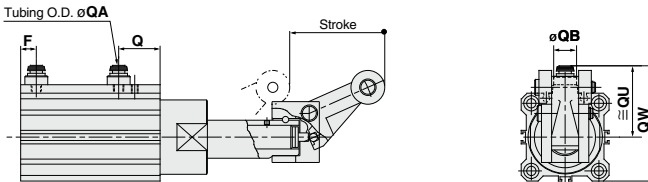

Built-in One-touch Fittings (mm)

Bore size (mm)	Applicable tubing O.D. 6QA	F	Q	QB	QU	QW
32	6	7.5	20	13	38	60.5
40	6	8	24.5	13	42	68
50	8	9.5	26	16	50	82

Bore size (mm)	A	B	E	I	J	K	M	N	O	T	Z
40	152.5	52.5	52	69	5	41	40	5.5	9 depth 7	44	14
50	154	54	64	86	7	50	50	6.6	11 depth 8	56	19

- Note 1) For the auto switch mounting position and its mounting height, refer to page 572.
 Note 2) These figures show the piston rod extended.
 Note 3) In the case of single acting type, a One-touch fitting is on the rod side only.
 Note 4) The position of the width across flats (K) is arbitrary and is not specified.

RSQ

RSQ

RS2H

RSH

MIW
MIS

D-□

-X□

Rod End Configuration: Lever Type with Shock Absorber

Variable energy absorbing type/ Through-hole mounting, Screw mounting type With lock mechanism

These 3 figures show the piston rod extended.

Bore size: $\phi 32$ RS□QB32-□□D

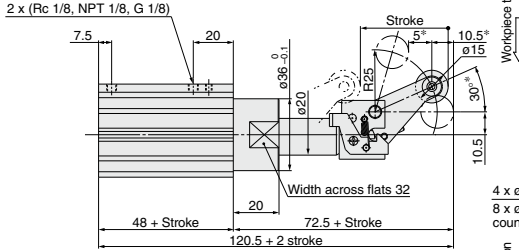

Screw mounting type: Both ends tapped type

RS□QA

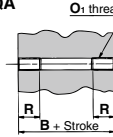

Model	B	O ₁	R
RS□QA32	48	M6 x 1	10
RS□QA40	52.5	M6 x 1	10
RS□QA50	54	M8 x 1.25	14

* Dimensions other than above are the same as below drawings.

Workpiece transfer direction

4 x $\phi 5.5$ through
8 x $\phi 9$ depth of counterbore 7 depth

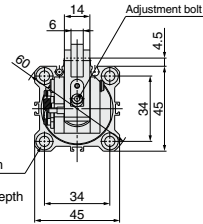

Bore size: $\phi 40, \phi 50$ RS□QB⁴⁰/₅₀-□□D

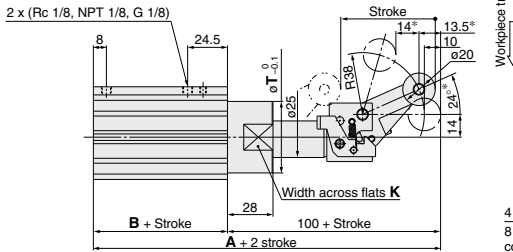

Workpiece transfer direction

4 x ϕN through
8 x ϕ depth of counterbore

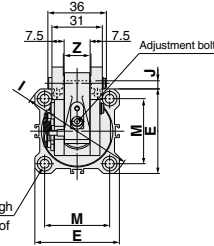

With lock mechanism + Cancel cap RS□QB□□-□□E

* Dimensions when equipped with lock and cancel cap are the same as the figure drawing.

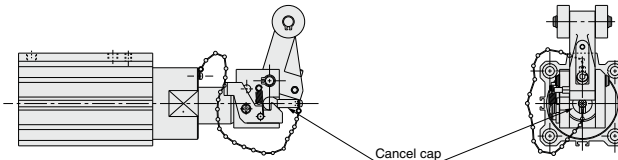

* These figures show dimensions when set for maximum energy absorbing capacity. (mm)

Bore size (mm)	A	B	E	I	J	K	M	N	O	T	Z
40	152.5	52.5	52	69	5	41	40	5.5	9 depth 7	44	14
50	154	54	64	86	7	50	50	6.6	11 depth 8	56	19

Note 1) For the auto switch mounting position and its mounting height, refer to page 572.

Note 2) These figures show the piston rod extended.

Note 3) In the case of single acting type, a One-touch fitting is on the rod side only.

Note 4) The figures shows the dimensions when the adjustment bolt is lowered (when energy absorption is at its maximum).

However, these dimensions change within the ranges shown below as the adjustment bolt is raised (energy absorption is reduced).

$\phi 32$.. $30^\circ \rightarrow 20^\circ$, $10.5^\circ \rightarrow 9^\circ$, $5^\circ \rightarrow 6^\circ$

$\phi 40, 50$.. $24^\circ \rightarrow 16^\circ$, $13.5^\circ \rightarrow 11.5^\circ$, $14^\circ \rightarrow 16^\circ$

Note 5) The position of the width across flats (K) is arbitrary and is not specified.

RSQ

RSG

RS2H

RSH

MIW

MIS

D-□

-X□

RSQ Series

Auto Switch Mounting 1

Auto Switch Proper Mounting Position (Detection at Stroke End) and Its Mounting Height

D-M9□
D-M9□W
D-M9□A
D-A9□

D-M9□V
D-M9□WV
D-M9□AV
D-A9□V

ø12

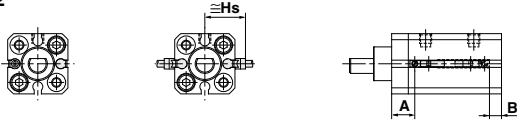

D-M9□
D-M9□W
D-A9□V
D-M9□V
D-M9□WV
D-M9□A
D-M9□AV
D-A9□

ø16, 20

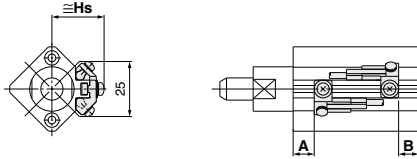

D-A7□
D-A80
D-A7□H
D-A80H
D-F7□
D-J79
D-F7□W
D-J79W
D-F79F
D-F7NT
D-F7BA
D-A73C
D-A80C
D-J79C
D-A79W
D-F7□WV
D-F7□V
D-F7BAV

ø16, ø20

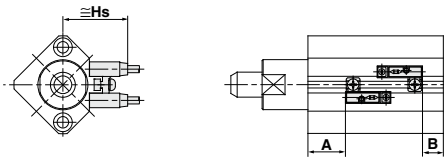

ø32 to ø50

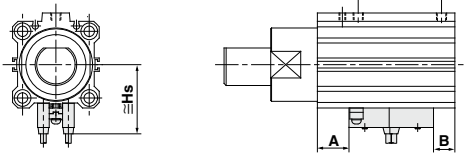

D-M9□
D-M9□W
D-M9□A
D-A9□

D-M9□V
D-M9□WV
D-M9□AV
D-A9□V

ø32 to ø50

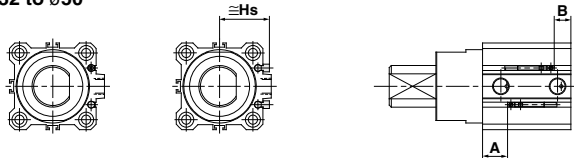

D-P3DWA

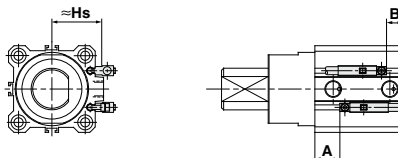

Auto Switch Proper Mounting Position (Detection at Stroke End) and Its Mounting Height

Auto Switch Proper Mounting Position

Auto switch model	D-M9□ D-M9□V D-M9□W D-M9□WV D-M9□A D-M9□AV		D-A9□ D-A9□V		D-A73 D-A80		D-A72/A7□H/A80H D-A73C/A80C D-F7□/J79 D-F7□V/J79C D-F7BAV/F7BA D-F7□W/J79W D-F7□WV/F79F		D-F7NT		D-A79W		D-P3DWA ^{Note 2)}	
	A	B	A	B	A	B	A	B	A	B	A	B	A	B
12	13	11	9	7	—	—	—	—	—	—	—	—	—	—
16	13	13	9	9	11.5	11.5	12	12	17	17	9	9	—	—
20	19	11	15	7	17.5	9.5	18	10	23	15	15	7	—	—
32	21	15	17	11	18	12	18.5	12.5	23.5	17.5	15.5	9.5	16.5	10.5
40	25.5	15	21.5	11	22.5	12	23	12.5	28	17.5	20	9.5	21	10.5
50	33.5	8.5	29.5	4.5	30.5	5.5	31	6	36	11	28	3	29	4

Note 1) Adjust the auto switch after confirming the operating conditions in the actual setting.
 Note 2) The D-P3DWA is mountable only on the port side.

Auto Switch Mounting Height

Auto switch model	D-M9□V D-M9□WV D-M9□AV		D-A9□V	D-A7□ D-A80	D-A7□H D-A80H/F7□ D-J79/F7□W D-F7BA D-J79W D-F79F D-F7NT	D-A73C D-A80C	D-F7□V D-F7□WV D-F7BAV	D-J79C	D-A79W	D-P3DWA
	Hs	Hs	Hs	Hs	Hs	Hs	Hs	Hs	Hs	Hs
12	19.5	17	—	—	—	—	—	—	—	—
16	23.5	23.5	22.5	23.5	29.5	26	29	25	—	—
20	25.5	25.5	24.5	25.5	31.5	28	31	27	—	—
32	29	27	31.5	32.5	38.5	35	38	34	35.5	—
40	32.5	30.5	35	36	42	38.5	41.5	37.5	39	—
50	38.5	36.5	41	42	48	44.5	47.5	43.5	45	—

Operating Range

Auto switch model	Bore size (mm)					
	12	16	20	32	40	50
D-M9□/M9□V D-M9□W/M9□WV D-M9□A/M9□AV	3	5	5.5	6	6	7
D-A9□/A9□V	6	9.5	9	9.5	9.5	9.5
D-A7□/A80 D-A7H/A80H D-A73C/A80C	—	12	12	12	11	10
D-A79W	—	13	13	13	14	14
D-F7□/J79 D-F7□V/J79C D-F7□W/J7□WV D-F7BAV/F7BAV D-F79F/F7NT	—	6	5.5	6	6	6
D-P3DWA	—	—	—	5.5	5	6

* Since this is a guideline including hysteresis, not meant to be guaranteed. (Assuming approximately ±30% dispersion) There may be the case to change substantially depending on an ambient environment.

* The values above for a bore size ø12 and over ø32 of D-A9□(V)/M9□(V)/M9□(V)/M9□(A)(V) types are measured when the current switch installation groove is attached without using the auto switch mounting bracket BQ2-012.

RSQ

RSQ

RS2H

RSH

**MIW
MIS**

D-□

-X□

Auto Switch Mounting 2

Auto Switch Mounting Bracket: Part No.

Auto switch mounting surface	Bore size (mm)		
	ø12	ø16, ø20	ø32, ø40, ø50
Auto switch model	Auto switch mounting surface A, B, C side	Auto switch mounting surface Only auto switch mounting rail surface	Auto switch mounting surface Port side A, B, C side
D-M9□ D-M9□V D-M9□W D-M9□VW D-M9□A D-M9□AV D-A9□ D-A9□V	Auto switch mounting brackets are not required.	① BQ-1 ② BQ2-012 Two kinds of auto switch mounting brackets are used as a set. 	Auto switch mounting brackets are not required.
D-P3DWA	—	—	—

Note 1) For each cylinder series, when a compact auto switch is mounted on the three sides (A, B and C above) other than the port side of bore sizes ø32 to ø50, the auto switch mounting brackets above are required. Order them separately from cylinders.

Ordering example:
RSDQB32-20-M9BW.....1 unit
BQ-2.....2 pcs.
BQ2-012.....2 pcs.

Note 2) Auto switch mounting brackets and auto switches are shipped together with cylinders.

[Mounting screw set made of stainless steel]

The following set of mounting screws made of stainless steel (including nuts) is available. Use it in accordance with the operating environment. (Please order BQ-2 separately, since auto switch spacers (for BQ-2) are not included).

BBA2: For D-A7/A8/F7/J7 types

D-F7BA/F7BAV auto switches are set on the cylinder with the stainless steel screws above when shipped. When an auto switch is shipped independently, BBA2 is attached.

Note 4) When D-M9□A(V) type is mounted on a side other than the ø32, ø40 or ø50 port side, order auto switch mounting brackets BQ2-012S or BQ-2, or a stainless steel screw set BBA2 separately.

Note 5) Refer to page 1051 for the details of BBA2.

Auto Switch Mounting Bracket Weight

Auto switch mounting bracket part no.	Weight (g)
BQ-1	1.5
BQ-2	1.5
BQ2-012	5

Note 3) Auto switch mounting brackets and auto switches are shipped together with cylinders.

Besides the models listed in How to Order, the following auto switches are applicable.

Other Applicable Auto Switches

Refer to pages 941 to 1067 for detailed auto switch specifications.

Auto switch type	Model	Electrical entry (Fetching direction)	Features
Reed	D-A73	Grommet (Perpendicular)	—
	D-A80		Without indicator light
	D-A73H, A76H	Grommet (In-line)	—
	D-A80H		Without indicator light
Solid state	D-F7NV, F7PV, F7BV	Grommet (Perpendicular)	—
	D-F7NWV, F7BWV		Diagnostic indication (2-color indicator)
	D-F7BAV		Water resistant (2-color indicator)
	D-F79, F7P, J79	Grommet (In-line)	—
	D-F79W, F7PW, J79W		Diagnostic indication (2-color indicator)
	D-F7BA		Water resistant (2-color indicator)
	D-F7NT		With timer

- * For solid state auto switches, auto switches with a pre-wired connector are also available. Refer to pages 1014 and 1015 for details.
- * Normally closed (NC = b contact), solid state switch (D-F9G/F9H types) are also available. Refer to page 959 for details.
- * D-A7/A8/F7/J7 cannot be mounted on ø12.

RSG Series



Spring Force (Single acting)

Bore size (mm)	(N)	
	Extended	Compressed
40, 50	13.7	27.5

* For Round bar type, Chamfered type and Roller type.



Made to Order Specifications

[Click here for details](#)

Symbol	Specifications
-XA□	Change of rod end shape
-XC3	Special port position

Model

Bore size (mm)		40	50
Mounting	Flange	●	●
Built-in magnet		●	●
Piping	Screw-in type	Rc 1/8	
	Built-in One-touch fittings	ø6/4	ø8/6
Action		Double acting, Single acting (Spring extended), Double acting with spring loaded	
Rod end configuration	Round bar type	●	●
	Chamfered type	●	●
	Roller type	●	●
	Lever type	●	●

Specifications

Action	Double acting, Double acting with spring loaded, Single acting (Spring extended)
Fluid	Air
Proof pressure	1.5 MPa
Maximum operating pressure	1.0 MPa
Ambient and fluid temperature	Without auto switch: -10 to 70°C * With auto switch: -10 to 60°C
Lubrication	Not required (Non-lube)
Cushion	Rubber bumper
Stroke length tolerance	$^{+1.4}$ ₀
Mounting	Flange type

* No freezing (for cylinders with or without an auto switch)

Bore Size/Standard Stroke

Bore size (mm)	(mm)	
	Rod end configuration	
40	Round bar type, Chamfered type, Roller type, Lever type with shock absorber	
50	20, 25, 30	

Weight

Action	Bore size (mm)	Rod end configuration	Cylinder stroke (mm)		
			20	25	30
Double acting Single acting, Spring extend	40	Round bar type, Chamfered type, Roller type	1.14	1.17	1.2
		Lever type with built-in shock absorber	1.38	1.41	1.44
Double acting with spring loaded	50	Round bar type, Chamfered type, Roller type	1.34	1.37	1.4
		Lever type with built-in shock absorber	1.56	1.59	1.62

Operating Ranges by Rod End Configuration

(Example 1) For roller type with transfer speed of 15 m/min. and the weight of transferred object of 30 kg.

(Example 2) Transfer speed of 15 m/min., Weight of transferred object of 60 kg, Friction coefficient $\mu = 0.1$, Lever type (Lever type with lock mechanism)

<How to read the graphs>

To select a cylinder based on the specifications above, find the intersection of the speed of 15 m/min. on the horizontal axis and the weight of 30 kg on the vertical axis in graph (1) below, and select **RSG□40-□□R** that falls in the cylinder operating range.

<How to read the graphs>

To select a cylinder based on the specifications above, find the intersection of the speed of 15 m/min. on the horizontal axis and the weight of 60 kg on the vertical axis in graph (3) below, and select **RSG□40-□□D** that falls in the cylinder operating range.

Roller Type/Round Bar Type/ Chamfered Type

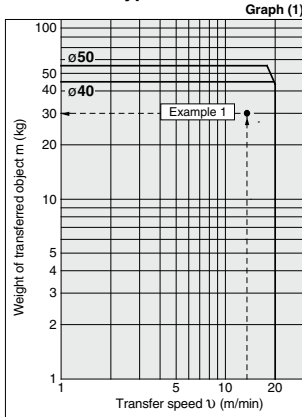

Lever Type (With shock absorber) Friction coefficient $\mu = 0$

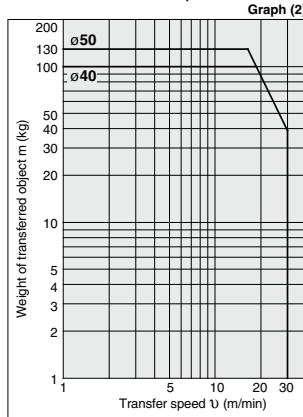

Lever Type (With shock absorber) Friction coefficient $\mu = 0.1$

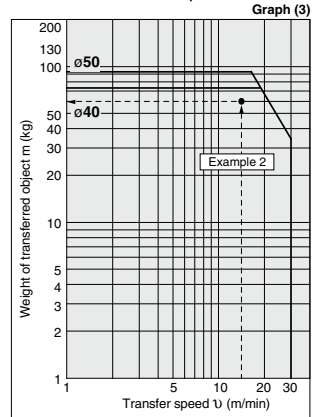

- * Lever-type weight of transferred object and transfer speed graphs (graphs (2) and (3)) show the values at room temperature (20 to 25°C).
- * When selecting cylinders, confirm the Specific Product Precautions as well.

Lateral Load and Operating Pressure

The larger the lateral load, the higher the operating pressure required for the stopper cylinder. Set the operating pressure using the graphs as a guide.

(Applicable for round bar, roller and chamfered type rod end configurations.)

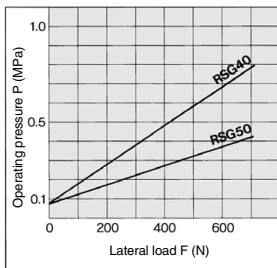

RSQ

RSG

RS2H

RSH

MIW

MIS

D-□

-X□

RSG Series

Construction

Roller rod end

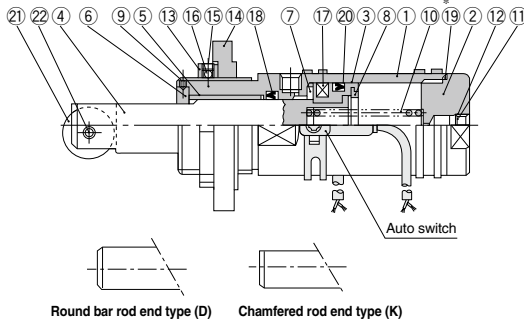

Lever rod end with shock absorber type (Fixed)

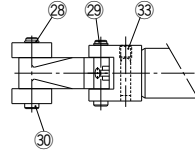

Lever rod end type (With lock mechanism and cancel cap)

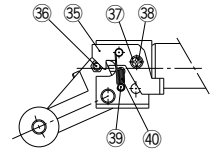
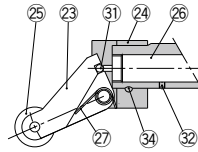
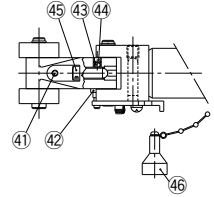

Component Parts

No.	Description	Material	Note
1	Tube cover	Aluminum alloy	Hard anodized
2	Head cover	Aluminum alloy	Anodized
3	Piston	Aluminum alloy	Chromated
4	Piston rod	Carbon steel	Hard chrome plated
5	Bushing	Bearing alloy	
6	Non-rotating guide	Rolled steel	Use collar for round bar type.
7	Bumper A	Urethane	
8	Bumper B	Urethane	
9	Hexagon socket head set screw	Chromium molybdenum steel	
10	Return spring	Steel wire	Zinc chromated (Except double acting)
11	Retaining ring	Carbon tool steel	(Single acting only)
12	Element	Sintered metallic BC	(Single acting only)
13	Lock nut	Carbon steel	
14	Flange	Cast iron	
15	Hexagon socket head set screw	Chromium molybdenum steel	
16	Ball	Resin	
17	Magnet	—	
18	Rod seal	NBR	
19	Gasket	NBR	Used Only for double acting and double acting with spring loaded.
20	Piston seal	NBR	

Replacement Parts/Seal Kit

Bore size (mm)	Kit no.			Contents
	Double acting	Double acting with spring loaded	Single acting	
40	RSG40D-PS	RSG40B-PS	RSG40T-PS	Set of above nos.
50	RSG50D-PS	RSG50B-PS	RSG50T-PS	⑬, ⑰, ⑳

* Seal kit includes ⑬, ⑰, ⑳. Order the seal kit, based on each bore size.

* Since the seal kit does not include a grease pack, order it separately.

Grease pack part no.: GR-S-010 (10 g)

Component Parts

No.	Description	Material	Note
Roller type			
21	Roller A	Resin	
22	Spring pin	Carbon tool steel	
Lever type			
23	Lever	Cast iron	
24	Lever holder	Rolled steel	
25	Roller B	Resin	
26	Shock absorber	—	RB1407-X552
27	Lever spring	Stainless steel wire	
28	Type C retaining ring for shaft	Carbon tool steel	
29	Lever pin	Carbon steel	
30	Roller pin	Carbon steel	
31	Steel balls	High carbon chrome bearing steel	
32	Hexagon socket head set screw	Chromium molybdenum steel	
33	Hexagon socket head set screw	Chromium molybdenum steel	
34	One-side tapered pin	Carbon steel	
With lock mechanism			
35	Bracket	Carbon steel	
36	Pin B	Carbon steel	
37	Spacer	Carbon steel	
38	Round head Phillips screw	Rolled steel	
39	Pin A	Rolled steel	
40	Bracket spring	Steel wire	
41	Hexagon socket head cap set screw	Chromium molybdenum steel	
42	Spring washer	Steel wire	
43	Urethane ball	Urethane	
44	Hexagon socket head cap set screw	Chromium molybdenum steel	
45	Adjustment bolt	Bearing steel	
With cancel cap			
46	Cancel cap	Aluminum alloy	

Replacement Parts: Shock Absorber

Bore size (mm)	Kit no.
40, 50	RB1407-X552

RSG Series

Rod End Configuration: Chamfered Type (Non-rotating piston rod)

Basic type: Flange mounting

These 2 figures show the piston rod extended.

Bore size: $\varnothing 40, \varnothing 50$ RS□G□-□□K

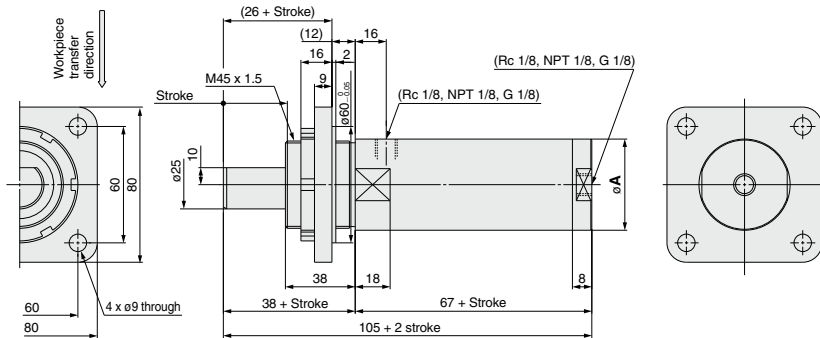

Built-in One-touch fittings

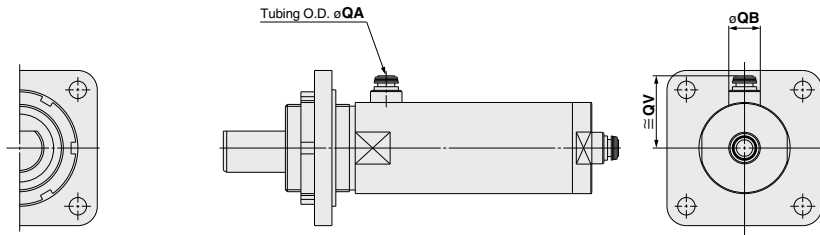

(mm)				
Bore size (mm)	A	QA	QB	QV
40	47	6	13	33
50	58	8	16	38.5

Note 1) In the case of single acting type, a One-touch fitting is on the rod side only.

Note 2) These figures show the piston rod extended.

Note 3) For the auto switch mounting position and its mounting height, refer to page 585.

Rod End Configuration: Roller Type

Basic type: Flange mounting

These 2 figures show the piston rod extended.

Bore size: $\varnothing 40, \varnothing 50$ RS□G□-□□R

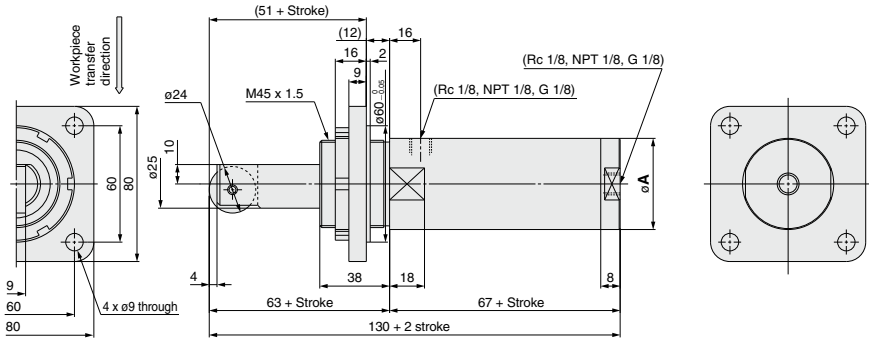

Built-in One-touch fittings

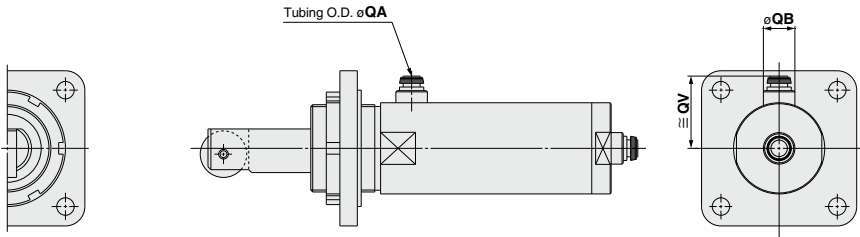

(mm)				
Bore size (mm)	A	QA	QB	QV
40	47	6	13	33
50	58	8	16	38.5

Note 1) In the case of single acting type, a One-touch fitting is on the rod side only.

Note 2) These figures show the piston rod extended.

Note 3) For the auto switch mounting position and its mounting height, refer to page 585.

RSQ

RSG

RS2H

RSH

MIW

MIS

D-□

-X□

RSG Series

Rod End Configuration: Lever Type with Shock Absorber

Basic type: Flange mounting

These 2 figures show the piston rod extended.

Bore size: $\phi 40, \phi 50$ RS□G□-□□L

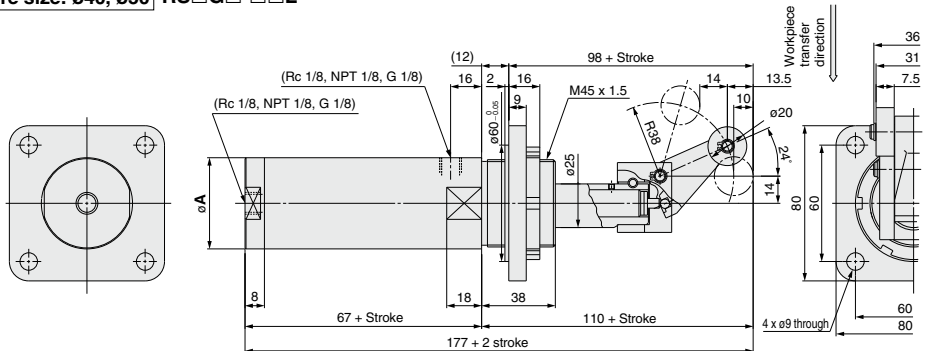

Built-in One-touch fittings

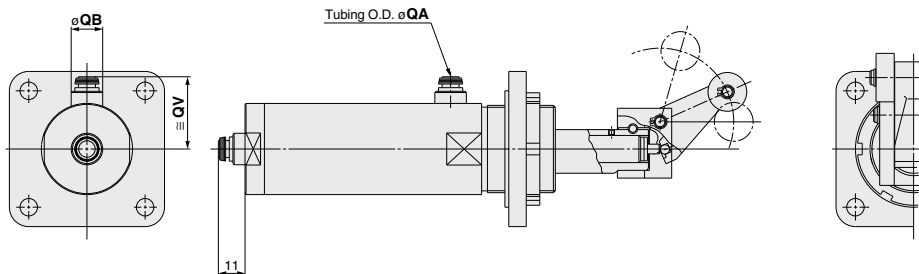

(mm)				
Bore size (mm)	A	QA	QB	QV
40	47	6	13	33
50	58	8	16	38.5

Note 1) In the case of single acting type, a One-touch fitting is on the rod side only.

Note 2) These figures show the piston rod extended.

Note 3) For the auto switch mounting position and its mounting height, refer to page 585.

Rod End Configuration: Lever Type with Shock Absorber

Variable energy absorbing type/Flange mounting type

These 2 figures show the piston rod extended.

Adjustable shock absorber stroke RS□G□-□□B

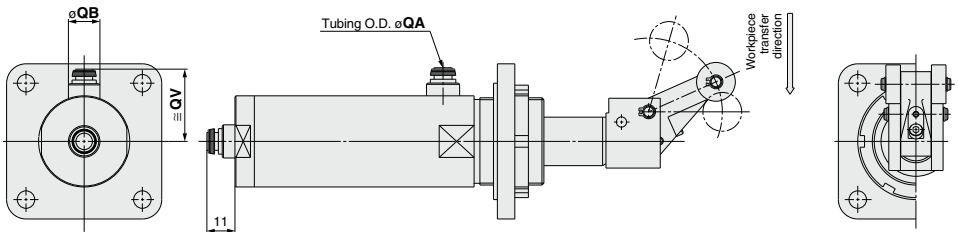
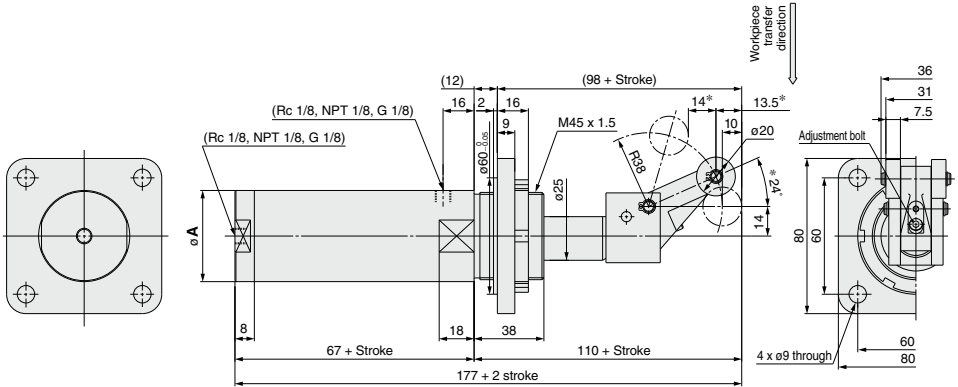

With cancel cap RS□G□-□□C

* Dimensions when equipped with cancel cap are the same as the drawing above.

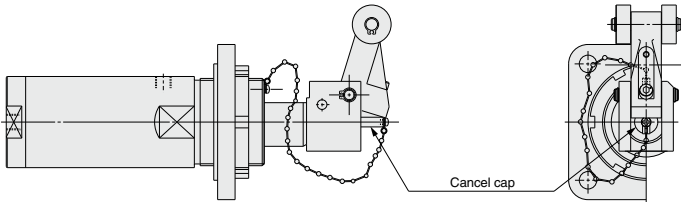

(mm)				
Bore size (mm)	A	QA	QB	QV
40	47	6	13	33
50	58	8	16	38.5

Note 1) In the case of single acting type, a One-touch fitting is on the rod side only.

Note 2) These figures show the piston rod extended.

Note 3) For the auto switch mounting position and its mounting height, refer to page 585.

Note 4) The figure shows these dimensions when the adjustment bolt is lowered (when energy absorption is at its maximum).

However, these dimensions change within the ranges shown below as the adjusting bolt is raised (energy absorption is reduced).

24° → 16°, 13.5° → 11.5°, 14° → 16°

RSQ

RSG

RS2H

RSH

MIW

MIS

D-□

-X□

Auto Switch Mounting 1

Auto Switch Proper Mounting Position (Detection at Stroke End) and Its Mounting Height

Reed Auto Switch

D-A9□

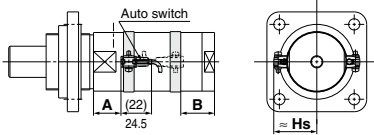

(): For D-A96 type

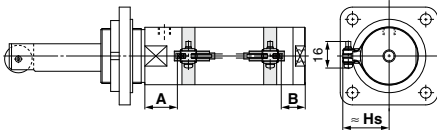

D-C7
D-C8
D-C73C
D-C80C

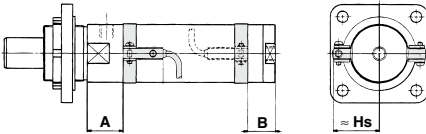

Solid State Auto Switch

D-M9□
D-M9□W
D-M9□A

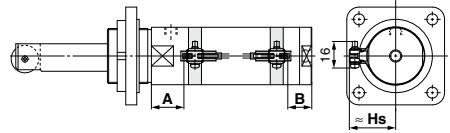
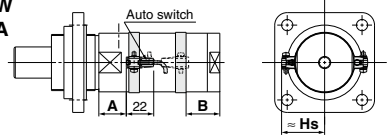

D-H7
D-H7□W
D-H7NF
D-H7BA
D-H7C

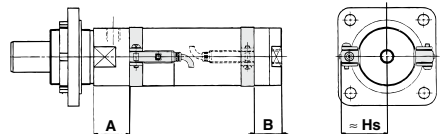

Auto Switch Proper Mounting Position (mm)

Auto switch model	(mm)							
	D-A9□ (Note 2)		D-M9□(V) (Note 2)		D-C7□		D-H7BA	
Bore size (mm)	A	B	A	B	A	B	A	B
	40	21.5	25.5	25.5	29.5	22.0	26.0	21.0
50	29.5	17.5	33.5	21.5	30.0	18	29.0	17.0

Auto Switch Mounting Height (mm)

Auto switch model	(mm)				
	D-M9□V	D-M9□W	D-M9□AV	D-M9□A	D-A9□
Bore size (mm)	Hs	Hs	Hs	Hs	Hs
40	36.0	35.0	38.0	37.5	37.5
50	41.5	40.5	43.5	43.0	43.0

Note 1) Adjust the auto switch after confirming the operating conditions in the actual setting.
Note 2) Auto switch mounting (The adjustment as shown in the figures below is required)

Auto switch model	With 2 auto switches	
	Different surfaces	Same surface
	<p>The proper auto switch mounting position is 6 mm inward from the switch holder edge.</p>	<p>The auto switch is mounted by slightly displacing it in a direction (cylinder tube circumferential exterior) so that the auto switch and lead wire do not interfere with each other.</p>

RSQ

RSG

RS2H

RSH

MIW

MIS

D-□

-X□

Auto Switch Mounting 2

Operating Range

Auto switch model	Bore size (mm)	
	40	50
D-A9□(V)	8	8
D-M9□(V) D-M9□W(V) D-M9□A(V)	4.5	5
D-C7□/C80 D-C73C/C80C	10	10
D-H7□/H7□W D-H7BA/H7NF	5	6
D-H7C	10	9.5

* Since this is a guideline including hysteresis, not meant to be guaranteed. (Assuming approximately ±30% dispersion) There may be the case to change substantially depending on an ambient environment.

Auto Switch Mounting Bracket: Part No.

Auto switch model	Bore size (mm)	
	ø40	ø50
D-A9□(V) D-M9□(V) D-M9□W(V)	Note 1) BMA3-040	Note 1) BMA3-050
D-M9□A(V)	Note 2) BMA3-040S	Note 2) BMA3-050S
D-C7□/C80 D-C73C/C80C D-H7□ D-H7□W D-H7BA D-H7NF	BMA2-040A	BMA2-050A

Note 1) Set part number which includes the auto switch mounting band (BMA2-□□□A) and the holder kit (BJ5-1/Switch bracket: Transparent). Since the switch bracket (made from nylon) are affected in an environment where alcohol, chloroform, methylamines, hydrochloric acid or sulfuric acid is splashed over, so it cannot be used. Please consult SMC regarding other chemicals.

Note 2) Set part number which includes the auto switch mounting band (BMA2-□□□AS/Stainless steel screw) and the holder kit (BJ4-1/Switch bracket: White).

Note 3) For the D-M9 A(V) type auto switch, do not install the switch bracket on the indicator light.

[Mounting screw set made of stainless steel]

The following set of mounting screws made of stainless steel is available. Use it in accordance with the operating environment. (Please order the auto switch mounting bracket separately, since it is not included.)

D-H7BA auto switch is set on the cylinder with the stainless steel screws above when shipped. When an auto switch is shipped independently, BBA4 is attached.

Note 4) Refer to page 1048 for the details of BBA4.

- (1) BJ□-1 is a set of "a" and "b".
BJ4-1 (Switch bracket: White)
BJ5-1 (Switch bracket: Transparent)
(2) BMA2-□□□A(S) is a set of "c" and "d".
Band (c) is mounted so that the projected part is on the internal side (contact side with the tube).

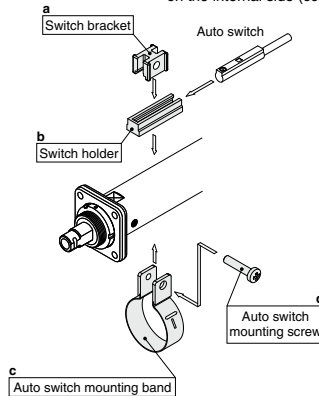

Besides the models listed in How to Order, the following auto switches are applicable. Refer to pages 941 to 1067 for detailed specifications.

Auto switch type	Part no.	Electrical entry (Direction)	Features
Reed	D-C73, C76	Grommet (In-line)	—
	D-C80		Without indicator light
Solid state	D-H7A1, H7A2, H7B		—
	D-H7NW, H7PW, H7BW D-H7BA		Diagnostic indication (2-color)

* For solid state auto switches, auto switches with a pre-wired connector are also available. Refer to pages 1014 and 1015 for details.

* Normally closed (NC = b contact) solid state auto switches (D-F9G/F9H types) are also available. Refer to page 957 for details.



RSQ/RSG Series

Specific Product Precautions 1

Be sure to read this before handling the products.

Refer to back page 50 for Safety Instructions and pages 3 to 12 for Actuator and Auto Switch Precautions.

Selection

Danger

1. Use within the range of specifications.

If using beyond the specifications, excessive impacts or vibrations could be applied to the stopper cylinder and might cause breakage.

Danger

1. Do not allow a pallet to collide with the cylinder when the lever is upright.

In the case of the lever type with built-in shock absorber, if the next pallet runs into the lever when it is in the upright position (after the shock absorber has assimilated energy), the cylinder body will receive the full energy of the impact, and this should not be permitted.

2. Do not apply pressure from the head side of a single acting type cylinder.

If air is supplied from the head side of a single acting cylinder, blow-by of the air will occur.

3. Do not scratch or gouge the sliding portion of a piston.

Quenching of the piston rod has not been performed. If there is a danger of scratching or nicking the piston rod due to sharp edges, etc. on the contact area of a pallet, the pallet should not be used, as this can cause a malfunction.

4. When using a stopper cylinder for intermediate stopping of a load connected directly to a cylinder, etc.

The operating ranges shown in this catalog apply only for stopping of a pallet on a conveyor. When using a stopper cylinder to stop a load connected directly to a cylinder, etc., the cylinder thrust will become a lateral load. In this case, refer to the operation manual and select a cylinder remaining within the allowable energy and allowable lateral load ranges.

5. For the lever type with a built-in shock absorber (without a lock mechanism), the lever may be pushed back in the opposite direction to the transfer direction due to the return force of the shock absorber, if 10N of thrust or more in the transfer direction is not applied to the lever after the pallet collides with the lever.

If the lever must be continuously upright, select a lever with a lock mechanism.

6. The operating range for the lever type with a built-in shock absorber indicates the range in which the lever is not damaged due to the shock absorber's performance and cylinder rigidity. It is not the same as the range in which the lever can stop softly and fully.

Near the upper limit, collision may occur at the end. If a soft stop is required, sufficient clearance is necessary. Consult with SMC when a reliable soft stop is required near the upper limit.

Mounting

Caution

1. Do not apply rotational torque to the cylinder rod.

In order to prevent rotational torque from acting upon the cylinder rod, mount it so that the contacting surfaces of the pallet and cylinder are parallel to one another.

When mounting a cylinder, tighten the body lock nut, and then tighten the set screws (2 locations) which are included with the lock nut. (Except RSQ)

2. When the lever type with a built-in shock absorber is installed from the direction of the lever side, mounting holes must be machined in accordance with recommend hole diameters in the table below.

When it is installed from the direction of the lever side of the stopper cylinder as shown below, note that the lever's outer diameter is larger than the rod cover boss diameter.

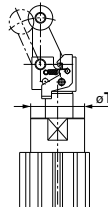
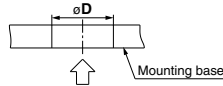

Figure 1

Lever type models

RS (D) □32/40/50-□□L
RS (D) □32/40/50-□□B
RS (D) □32/40/50-□□C
RS (D) □32/40/50-□□D
RS (D) □32/40/50-□□E

Table 1 Recommended hole diameter

Model	Rod cover boss O.D.		Recommended hole diameter for mounting base
	ϕT	ϕD	
RS (D) □32	36	38	
RS (D) □40	44	48	
RS (D) □50	56	57	

Operation

Caution

1. For models having the rod end configuration with the lever type with lock mechanism, do not apply any external force from the opposite side when the lever is locked. Doing so may cause the lock mechanism to break.

When moving pallets during conveyor adjustments, first lower the cylinder.

2. Do not use oil, etc. on the sliding parts of the piston rod.

This can cause trouble with retraction or other malfunctions.

3. Do not get your hands caught during cylinder operation.

Since the lever section moves up and down when the cylinder is in operation, take sufficient care to avoid getting your hands caught between the rod cover and the lever holder.

4. Do not expose the shock absorber to machining oil, water, or dust.

This can cause oil leakage and malfunction of the shock absorber.

RSQ

RSG

RS2H

RSH

MIW

MIS

D-□

-X□



RSQ/RSG Series

Specific Product Precautions 2

Be sure to read this before handling the products.

Refer to back page 50 for Safety Instructions and pages 3 to 12 for Actuator and Auto Switch Precautions.

Maintenance

⚠ Caution

1. How to replace the shock absorber

- 1) Loosen the hexagon socket head set screw (M3) on the piston rod.

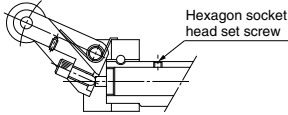

- 2) With the lever laid down as shown in the figure, pull out the shock absorber to remove it and replace this shock absorber with a new one.

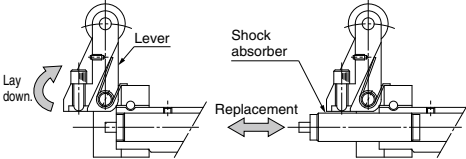

- 3) Insert the hexagon socket head set screw into the piston rod, and then tighten it.
After the hexagon socket head set screw has been in contact with the end, tighten it further 1/4 turn as a guideline. If the hexagon socket head set screw is tightened excessively, this may cause it to break or the shock absorber to malfunction.
Tightening torque: 0.29 N·m

2. How to change the piston rod orientation

For the roller type and lever type, put the pallet in contact with the piston rod in the direction shown in the figure. (The piping port position has been made flush with the pallet contact surface at the factory shipment.)

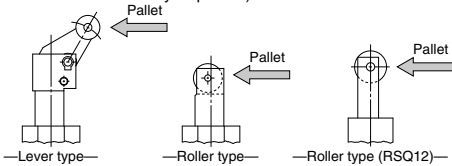

RSQ12 / How to change the piston rod orientation

- 1) Loosen the hexagon socket head cap screws (2 locations) that secure the rod cover and cylinder tube.
- 2) Adjust the orientation of the rod cover to a desired position. The orientation of the rod cover can be changed in 90° steps.
- 3) Tighten two hexagon socket head cap screws on the diagonal line to secure the rod cover and cylinder tube. When tightening the hexagon socket head cap screws, apply the thread locking agent.
Tightening torque: 1.5 N·m
- 4) Make sure that the cylinder operates smoothly.

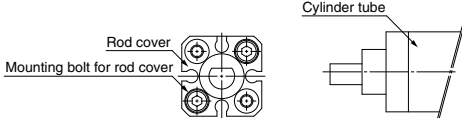

⚠ Caution

RSQ20 to 50 / How to change the piston rod orientation

- 1) Loosen two hexagon socket head cap screws (M3) on the rod cover that secure the non-rotating guide.
- 2) Adjust the orientation of the piston rod to a desired position.
Note) Put the pallet contact surface in parallel to the cylinder contact surface so that the rotational torque does not apply to the piston rod.
- 3) Tighten two hexagon socket head cap screws to secure the non-rotating guide. When tightening the hexagon socket head cap screws, apply the thread locking agent.
Tightening torque: 0.63 N·m
Note) The non-rotating guide is secured by two hexagon socket head cap screws. If one hexagon socket head cap screw is tightened excessively, the non-rotating guide may be in contact with the piston rod, causing malfunction. Therefore, tighten the hexagon socket head cap screws alternately and pay special attention so that the non-rotating guide is not in contact with the piston rod.
- 4) Make sure that the cylinder operates smoothly.

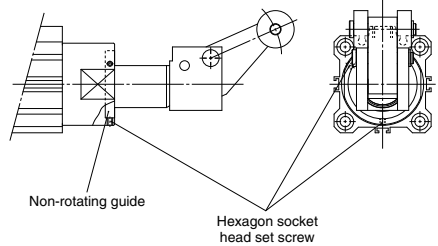

3. How to adjust the lever type, variable energy absorbing type

For the lever type, variable energy absorbing type, strokes of the shock absorber can be adjusted with an adjustment bolt included in order to stop in accordance with the transfer conditions.

Follow the procedures below to adjust strokes.

Procedures

- 1) Loosen the set screw (M4) on the lever side.
- 2) Adjust the adjustment bolt in accordance to the energy of the transferred object.
(The stroke of the shock absorber becomes larger (absorbing energy becomes bigger) when tightening the adjustment bolt, while it becomes smaller when loosening the bolt.)
- 3) After adjusting the adjustment bolt, fix the bolt with the set screw (M4) loosened in 1).
Tightening torque M4: 1.5 N·m

